

4^D

The Wireless World

THE PRACTICAL RADIO JOURNAL
with

Complete Foreign Programmes

Friday, October 13th, 1933.

TELSEN Intermediate Frequency TRANSFORMER COILS

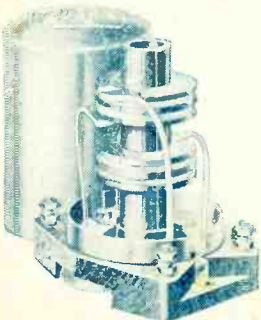

Specified by the designer of the "Wireless World" NEW MONODIAL SUPER. Ideal for every superhet where lasting efficiency is the first essential. Totally screened. The world's finest value at the new reduced price of **7'6**

TELSEN FOR EVERYTHING IN RADIO

Announcement of the Telsen Electric Co., Ltd., Aston, Birmingham.

SONOCHORDE The Supreme Reproducer

Sonochorde has brought sound reproduction to the highest standard of REALISM ever attained... you will be astounded at the fine performance, the perfect design and workmanship of these new models. The revolutionary concentric disc suspension which ensures permanent alignment of the speech coil with added sensitivity places Sonochorde in the forefront of advanced speaker craftsmanship. Write to-day for the Sonochorde Broadsheet.

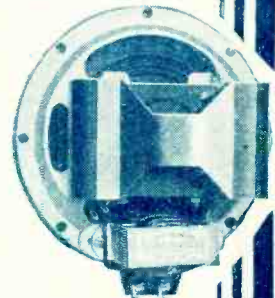

SONOCHORDE REPRODUCERS LTD.

1, Willesden Lane, N.W.6.

**Phone: Maida Vale 6066 (5 lines)*

D.C. MODELS
(2500 or 6500 ohms)
17'6
P.M. MODEL
21'-
with power or Pentode Transformer.

The NAME
DUBILIER
on a
CONDENSER



is
your
guarantee of
SATISFACTION

Dubilier Condenser Co. (1925) Ltd. Ducon Works, Victoria Rd., N. Acton, W 3.

H.T. PERMANENTLY! MAINTAINED! BY AN ORDINARY L.T. BATTERY

M-L Anode Converters merely require connecting to a 6 or 12 v. L.T. Battery to give smooth, constant H.T. and G.B. Current. Models from £8.

Special Models for McMichael, G.E.C., Philips and Peto-Scott short-wave receivers £9.10.0. Eddystone Model £8.5.0. Models also for Mavox, Scott Sessions and other short-wave receivers.

WITH
AN



★ THE ORIGINAL MACHINE for this purpose; first introduced 1922.
★ Generates pure D.C.
★ Takes only modest current. ★ Built to last.

MODELS TO SUIT ALL RECEIVERS
Write for full details!

ROTAX LTD., RADIO DEPT. 1,
WILLESDEN, LONDON, N.W.10.

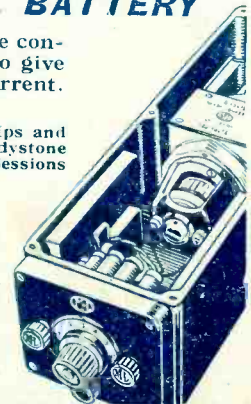

ANODE CONVERTER

The Wireless World

A.V.C. THREE
FOR A.C. MAINS

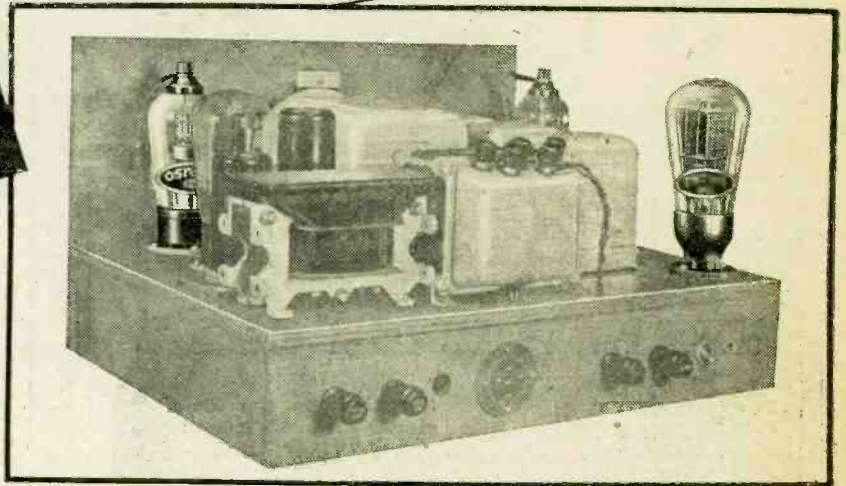

The "Wireless World" A.V.C. THREE

MHD4

Indirectly Heated Double Diode Triode for Detection & A.V.C. in A.C. Sets.
Price 15/6 each.

MU12

Indirectly Heated Full Wave Rectifying Valve.
Price 15/- each.

Osram Valves

RECOMMENDED

MADE IN ENGLAND

Sold by all Radio Dealers

For full Technical information WRITE for the OSRAM VALVE GUIDE. Post Free on request.

Advt. of The General Electric Co. Ltd., Magnet House, Kingsway, London, W.C.2.

Mention of "The Wireless World," when writing to advertisers, will ensure prompt attention.

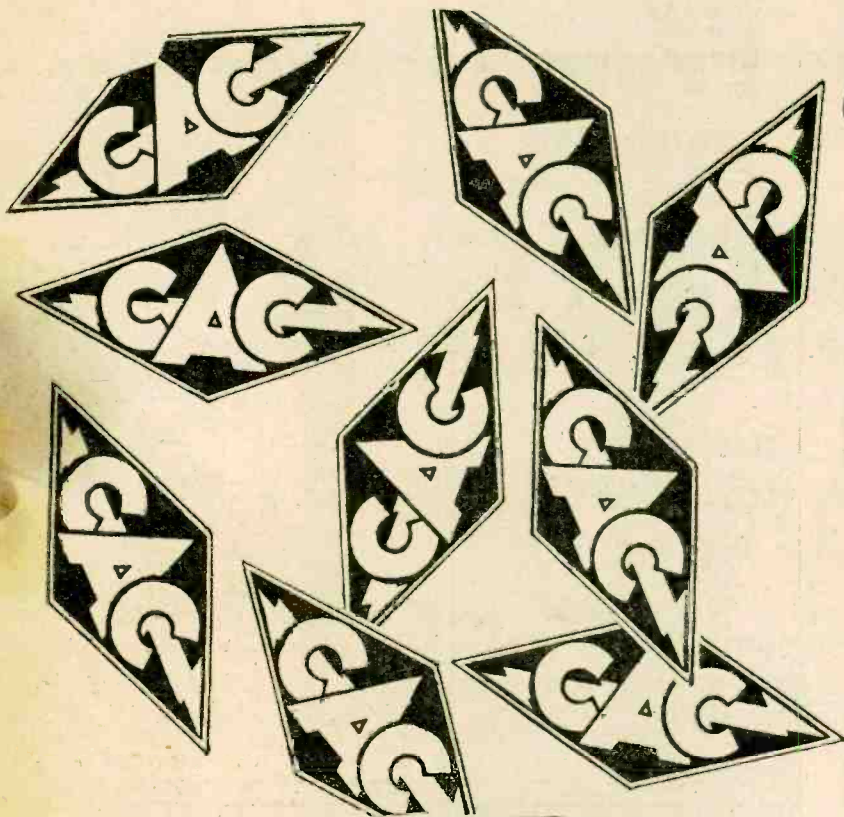

ALL OVER THE SHOW

OLYMPIA!
GLASGOW!!
MANCHESTER!!!

Have you seen C.A.C.'s Display?
That was the question.

WHY? For four simple reasons.

- Originality in design.
- Quality of workmanship.
- Real value for money.
- Individual requirements catered for.

C.A.C. Cabinets are furniture which is a delight to the eye, and into them receivers of the most advanced radio technique are built.

We have broken away from hide-bound tradition and the success of this departure has been made manifest at these Exhibitions, to the point that we are justly proud of our success.

The stock models displayed on our Stands at Radiolympia, Glasgow and Manchester are a criterion of the craftsmanship that will be put into YOUR order.

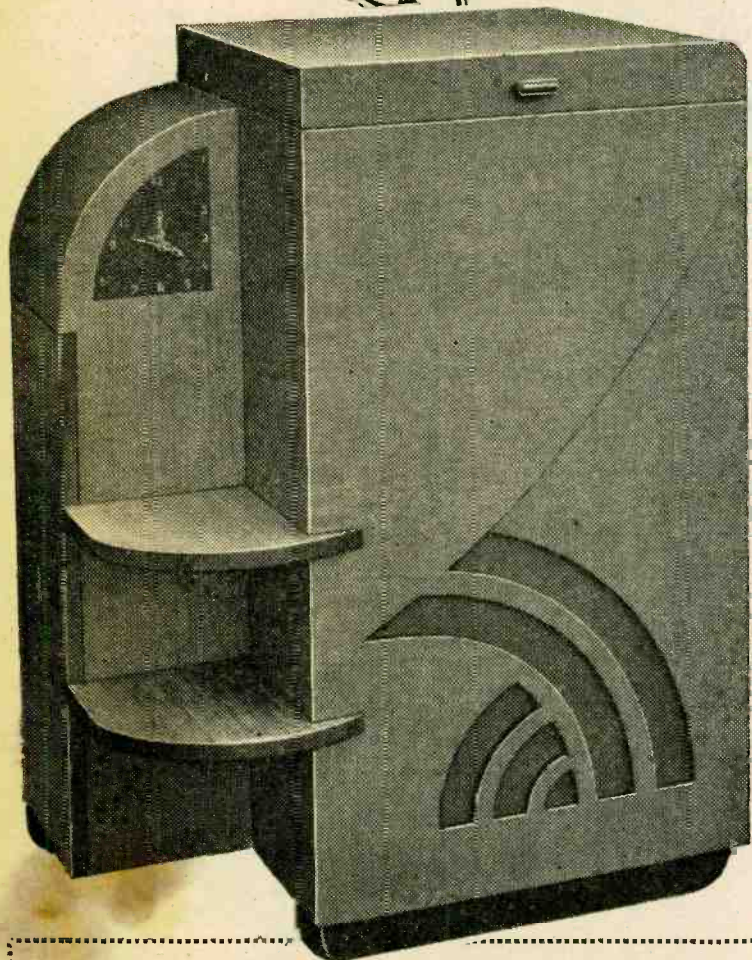

The "C.A.C." COCKTAIL RADIO-GRAM CABINET.

This ultra-modern piece of furniture created immense interest at Radiolympia, where it was shown for the first time, and obtained for itself more press publicity than any other exhibit in the show. Provision is made for the accommodation of Combined Radio-Gramophone equipment, whilst on the left is fitted a spacious enclosed cupboard, admirably suited for a Cocktail Cabinet. Alternatively, it can be used as a storage compartment for Gramophone Records.

In Burr Walnut, Mahogany or Oak, 16 Guineas.

Complete with "MONODIAL SUPER," Electric Clock, Garrard Automatic Record Changer, "Rola" Loud Speaker, Aerial tested and fully guaranteed, Quotations for alternative Receivers on request. **64 Guineas.**

The C.A.C. PENTAGRID SUPERHET.

A four-valve A.C. Superhet of highly specialised technique using a Pentagrid Converter as a single-valve frequency changer, which performs the dual functions of oscillator and first Detector in the most efficient manner known. In the I.F. stage a variable-mu Pentode is used, which adds its contribution to A.V.C. The third valve is one of the new double Diode Pentodes, which gives almost perfect automatic volume control, and the fourth valve is a Catkin Pentode. The output is in the order of 2½ watts, whilst the sensitivity of this Receiver is a revelation. The four special valves give an overall performance equal to that of any six-valve superhet on the market.

Price 14 GUINEAS.

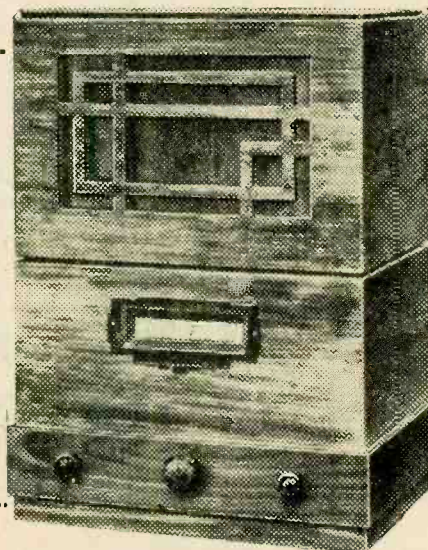

NOTE THE SEPARATE SPEAKER

SEND TO-DAY FOR OUR 1933-34

ILLUSTRATED CATALOGUE

OF RECEIVERS, RADIO-GRAMS AND CABINETS.

Also PRICE LISTS OF "WIRELESS WORLD" KITS including The Ferrocart Class "B" Receiver and the

NEW MONODIAL SUPER.

CITY ACCUMULATOR Co. Ltd.

18-20, NORMAN'S BUILDINGS (off Central Street), LONDON, E.C.1

Telephones: Radio Dept.—Clerkenwell 6206. Telegrams: Cabinet Dept. "Cityacco Barb, London."

**HOW
CLEAR IT
IS!
WHEN**

**EVER
READY**
REGD. TRADE MARK

**WIRELESS
BATTERIES ARE
POWERING
YOUR SET**

HAVE YOU A MARCONI 55!

Then you need Ever Ready Batteries: H.T. Port. 17; G.B.4; L.T. 2169 — all made specially for it. Or simply ask your dealer for the Ever Ready List, showing all popular makes with their special Ever Ready Batteries. Your set will be powered perfectly by its appropriate Ever Ready Batteries.

The Ever Ready Co. (Gt. Britain) Ltd., Hercules Place, Holloway, London, N.7.

**From
every
point
of view**

*design
construction
performance
and price—*

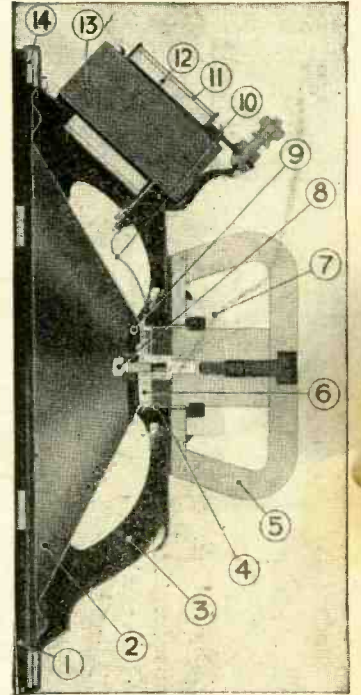

Sectional view of "CHALLENGER" P.M. M.C. Reproducer. Write for explanatory leaflet.

**R & A
Reproducers
lead**

It is on design and construction that the ultimate performance depends—the dimensions of parts, their correlation; a quality of material, accuracy of machining, skilled workmanship and the employment of precision gauges and testing apparatus at every stage to ensure complete uniformity.

Not only upon design, but also on the most scientific production methods depend the pre-eminence of R. & A. Reproducers.

That is why R. & A. performance is the accepted standard by which sound reproduction is judged, and why you should purchase (because you want this high standard of performance) an R. & A. Reproducer.

*Your dealer will gladly demonstrate.
Prices range from 21/- to 70/-.*

**R & A
BRITAIN'S FOREMOST
REPRODUCERS**

REPRODUCERS & AMPLIFIERS LTD., WOLVERHAMPTON

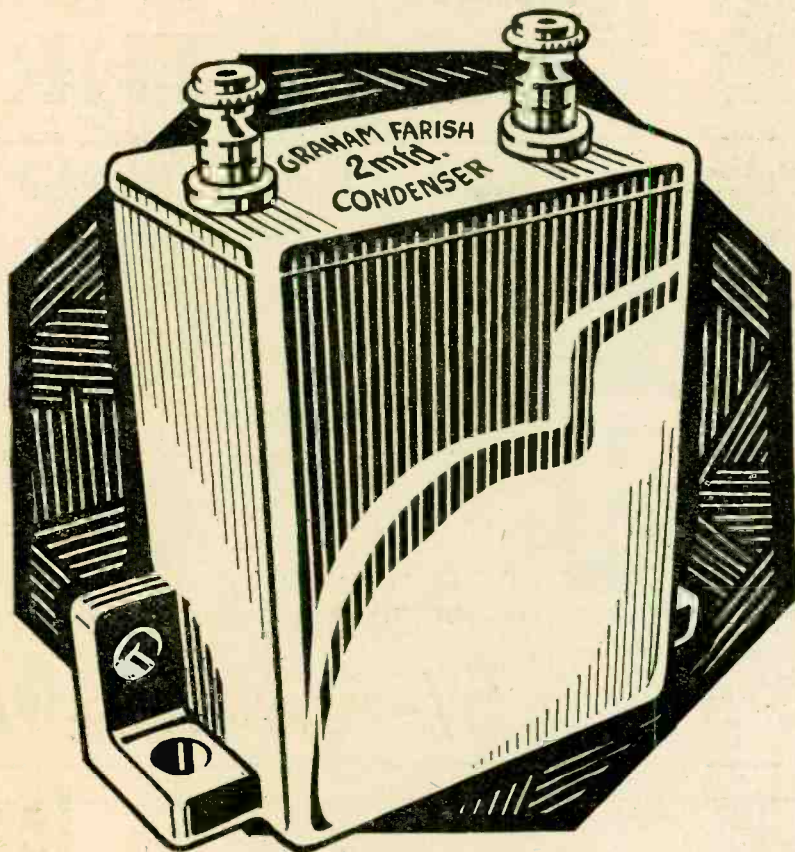

The
Condensers
with an
inner
difference

NON-INDUCTIVE CONDENSERS

Designed for years of good service. 500-volt test, 250-volt D.C. working. Insulation resistance, 5,000 megohms per mfd. Handsome Bakelite moulded case, providing both upright or flat mounting (Reg. design 723271), with large terminals. A handsome and extremely efficient component at a modest price.

·25 mfd. **1/6**
·5 mfd. 1/9 1 mfd. 2/- 2 mfd. 3/-

GRAHAM FARISH PRODUCTS



Send a postcard for our new Catalogue which describes all our products.



TUBULAR CONDENSERS

Wire ends anchored by means of eyelets in tube, avoiding any strain on the insert. 250-volts working, 500-volts D.C. test. Very high insulation resistance, hermetically sealed, high quality bakelite tubes made in various sizes.

·0001 mfd. to ·008 **1/-**
·01 mfd. **1/3** ·02 to 25 mfd **1/6**

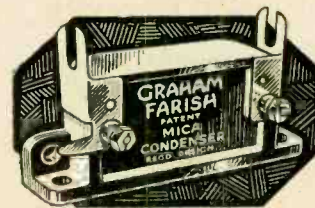

FIXED CONDENSER

In a complete range of capacities, upright or flat mounting. Every condenser is tested on 750 volts D.C. Capacities accurate within fine limits.

·0005 mfd. to ·004 mfd. **1/-**
·005 mfd. to ·01 mfd. - - - **1/6**

Ensure a safe and efficient Aerial and Earth. The new **AEROFICIENT KIT** provides all you need.

6/6 Complete.

Advertisement of GRAHAM FARISH LTD., Masons Hill, BROMLEY, Kent.

Export Office : 11/12 Fenchurch St., E.C.3.

Advertisements for "The Wireless World" are only accepted from firms we believe to be thoroughly reliable.

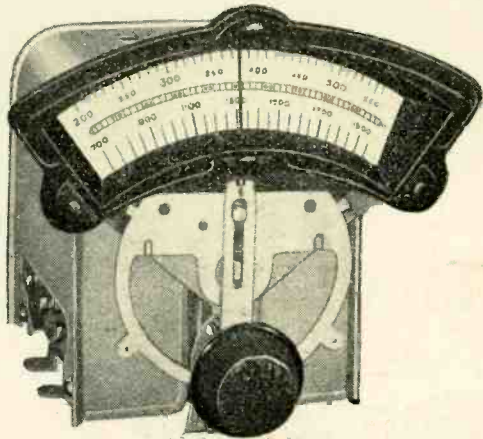

POLAR STAR MINOR THREE GANG
 Cadmium Plated Steel frame mounted on flexible baseplate. Sections matched within $\frac{1}{4}\%$ or 1 mmfd. (whichever is the greater). Trimmers operated from top. $3 \times .0005$ Condenser only **18/9**

Complete with Arcuate dial, as illustrated (calibrated in wavelengths and $0^\circ-100^\circ$)..... Price 24/6
 Complete with Panel Mounting Disc Drive (calibrated $0^\circ-180^\circ$)..... 23/9
 Complete with Moving Scale Disc Drive (calibrated in wavelengths and $0^\circ-180^\circ$)..... 23/3

The Polar Star Minor 3 gang Condenser is approved by the designer of the "A.V.C. Three." Its accuracy and dependability are features which assure its perfect tuning.

Three alternative drives are available, each designed to operate with the Star Minor Condenser, thus giving scales calibrated either in degrees or wavelengths.

WINGROVE & ROGERS LTD.
 188-9, Strand, London, W.C.2.

Phone: Temple Bar 2244/5/6.
 Polar Works: Old Swan, Liverpool.

POLAR

CONDENSERS & DRIVES

Recommended for the

A.V.C THREE

Polar Drives suitable for the 'Star Minor' 3 Gang

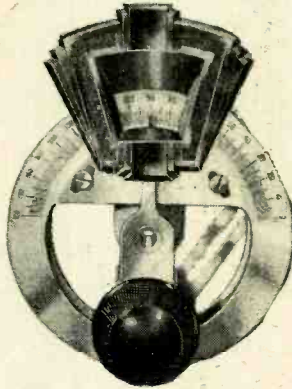

POLAR PANEL MOUNTING DRIVE

A slow motion drive with bevelled scale mounted behind panel. Operates either single or gang condensers. Provided with lampholder Moulded escutcheon
 Price **5/-**

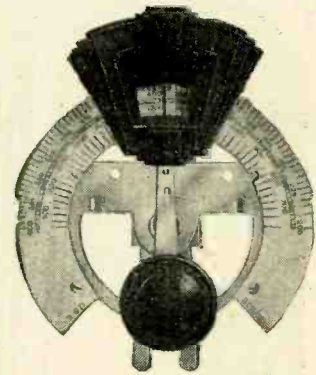

POLAR MOVING SCALE DRIVE

Slow motion drive fitted with moving scale. Calibrated in wavelengths and degrees. Moulded escutcheon. Can be supplied with air dielectric trimmer of 50 mmfd. variation fitted to drive on the "Uniknob" principle at 2/- extra.
 Price **4/6**

3785

Advt. of Tungram Electric Lamp Works (Gt. Britain) Ltd., 72 Oxford St., W.1



"CRACKED AGAIN! You're a disgrace! You haven't been sticking to Tungram valves, my lad — no note ever got cracked from one of those. They're too particular!"



- THERE'S A TUNGSRAM VALVE FOR EVERY RADIO NEED
- TUNGSRAM'S VIVID TONE PUTS NEW LIFE INTO OLD SETS
- FULL RANGE OF UNIVERSAL A.C./D.C. VALVES
- IF YOU'VE A RADIO PROBLEM, WRITE OUR TECHNICAL DEPARTMENT AND THEY WILL HELP YOU GLADLY

TUNGSRAM

THE WORLD'S FINEST BUT AT PRICES FROM 5/6

BARIUM VALVES

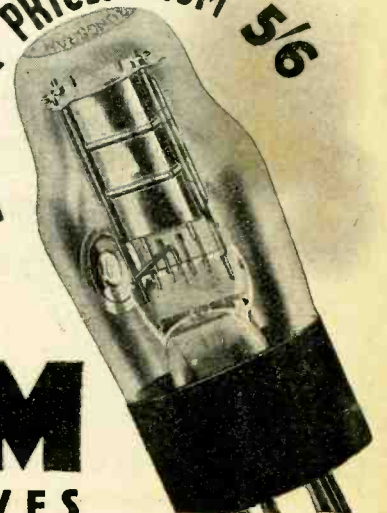

Mention of "The Wireless World," when writing to advertisers, will ensure prompt attention.

Wherever
wireless
terms are
understood
"Ohmite"
means
"The
Best
Resistance"

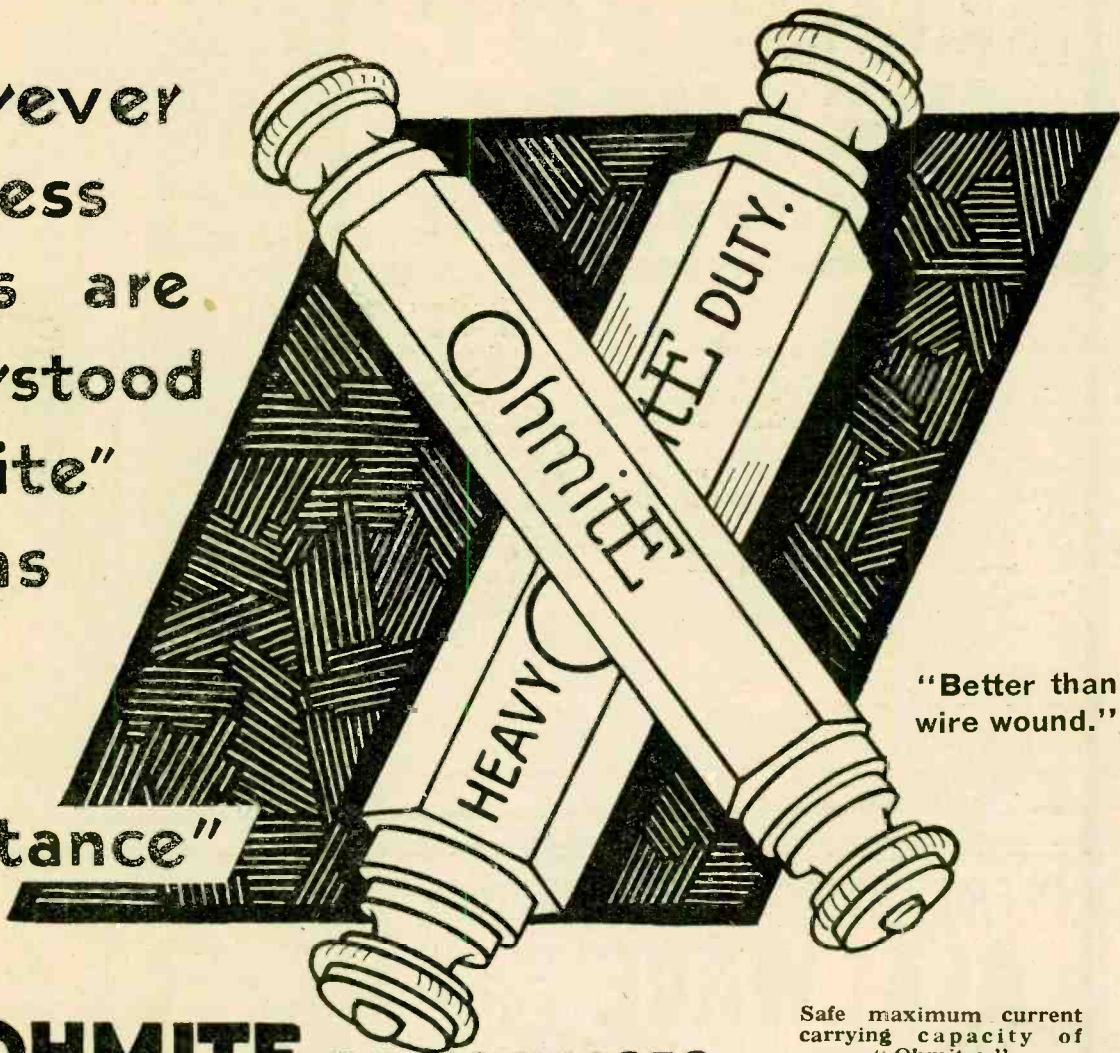

"Better than
wire wound."

OHMITE RESISTANCES

The most popular and efficient type of fixed resistance for all general purposes. "Better than wire wound." All values, 50 ohms to 5 megohms.

HEAVY DUTY TYPE 2/3

1/6

GRAHAM FARISH PRODUCTS



Safe maximum current carrying capacity of "Ohmites."

100° F Temperature Rise			
Ohms.	Milliamps.	Ohms.	Milliamps.
1,000	40	20,000	8
2,000	35	30,000	6-75
3,000	29	40,000	6
4,000	24	50,000	5-5
5,000	20-25	60,000	5
10,000	12	80,000	4-24
Other values pro rata		100,000	3-5

Safe maximum current carrying capacity of "Ohmites" Heavy Duty Type.

100° F Temperature Rise			
Ohms.	Milliamps.	Ohms.	Milliamps.
1,000	80	20,000	16
2,000	70	30,000	13-5
3,000	58	40,000	12
4,000	48	50,000	11
5,000	40-5	60,000	10
10,000	24	80,000	8-48
Other values pro rata		100,000	7

Ensure a safe and efficient Aerial and Earth. The new AEROFICIENT KIT provides all you need. Complete 6/6
Send a postcard for our new Catalogue, which describes all our products.

Advertisement of GRAHAM FARISH LTD., Masons Hill, BROMLEY, Kent.

Export Office: 11/12, Fenchurch Street, E.C.3.

Test BLUE SPOT SPEAKERS and hear the difference

The very high standard of performance given by Blue Spot Speakers is due simply and solely to "QUALITY." In design, workmanship and materials used in construction only the very best quality is good enough for Blue Spot.

As a result Blue Spot Speakers give a performance that is as near to perfection as modern technical science has yet been able to approach. On any comparative test—appearance, construction, performance—Blue Spot Speakers will quickly prove their superiority.

CUT THIS OUT FOR FREE CATALOGUE

Just write your name and address in the margin and post in open envelope (Hd. stamp). W.W.83.5

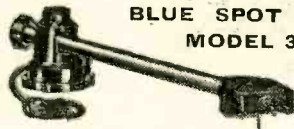

BLUE SPOT PICK-UP
MODEL 33

with wire wound volume control
and rotating head ... 35/-

THE BRITISH BLUE SPOT COMPANY, LTD.
Blue Spot House, 94-96, Rosoman St., Rosebery Avenue, LONDON, E.C.1
Phone: Clerkenwell 3570. Telegrams: "Bluspot, Italy, London."
Distributors for Northern England, Scotland & Wales: H. C. RAWSON
(Sheffield & London), Ltd., 100, London Rd., Sheffield; 22, St. Mary's Par-
sonage, Manchester; 177, Westgate Rd., Newcastle-upon-Tyne; 37, 38, 39,
Clyde Place, Glasgow.

MOVING COIL SPEAKERS 32'6 to 87'6 MOVING IRON SPEAKERS, 12'6 to 42'-

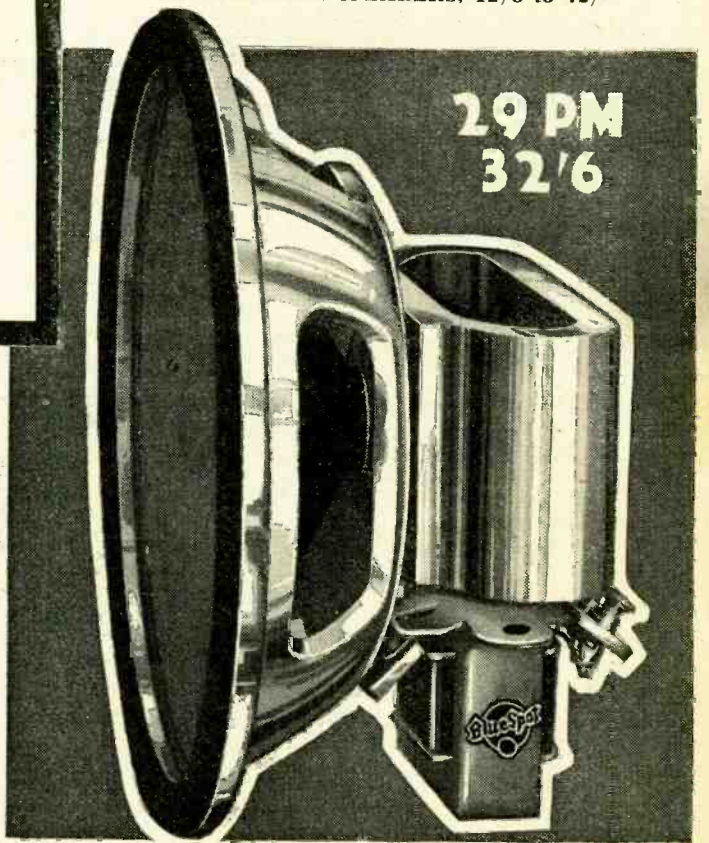

CONVERT YOUR SET INTO AN ALL WAVE SET

for **9'6** only **9'6**

All wavelengths
from 14.5 to
2,000 metres
covered by this
British General
All-wave Tuner.

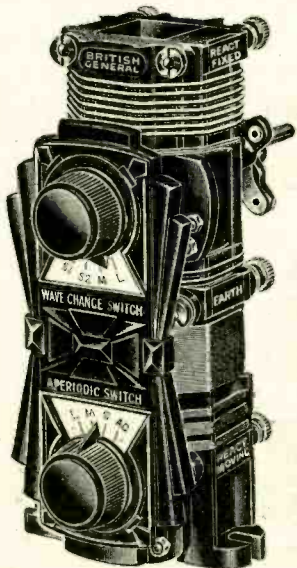

Free wiring
diagrams, show-
ing how you
can build or
convert your
set, supplied
Free. State
circuit when
ordering.

From all dealers or direct from the manufacturers—

BRITISH GENERAL

MANUFACTURING CO., LTD., BROCKLEY WORKS, LONDON, S.E.4

VORTEXION

Transformers of Superlative Quality

Specified by the Designer of
"The Wireless World"

A.V.C. THREE

VORTEXION A.C. 34 TRANSFORMER

passed "The Wireless World" Test—
a proof of its quality.

Every Transformer is massively built
of best quality material. Varnished
paper interleaving, subjected to 2,000
volts test between windings, ensures
an exceptionally large safety factor.

VORTEXION WILL NEVER LET YOU DOWN.

TRADE SUPPLIED.

SPECIAL POWER SMOOTHING CHOKES

for this receiver 30 henrys 50 m.a.

7'6

For complete range of Mains
Transformers and Chokes see under
Miscellaneous Advertisements.

VORTEXION

182, The Broadway, Wimbledon, S.W.19.

Phone: Liberty 2814.

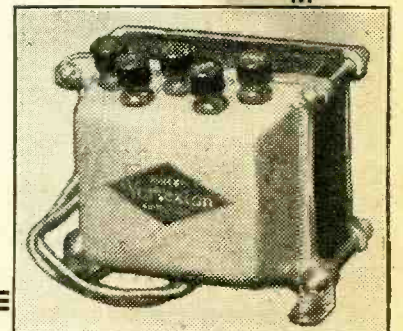

Mention of "The Wireless World," when writing to advertisers, will ensure prompt attention.



Technical Information Concerning the Mazda AC/S2. Pen. and AC/HL. DD.

WE want to give you a few points in connection with these two valves, because we feel that they will be of interest to those who follow valve development.

Let us start with the AC/S2. Pen.

The main function of this valve is for use as a self-oscillating frequency changer (or first detector) in a super-heterodyne receiver. The chief point to remember is that this valve has the highest slope and conversion conductance ever achieved in a screened pentode valve. In point of fact, the conversion conductance, when used as a frequency changer, is over 2,000 microamperes per volt. This means that with 100,000 ohms coupling coils the gain when used as a frequency changer is over 200. With 250,000 ohms coupling coils the gain when used as a frequency changer is over 500 and gives twice the efficiency of conversion of any other valve. This valve can handle very large outputs without any harmonic distortion. Consequently "whistles," "squeals" and "birdies," which are common to many super-heterodyne receivers, are reduced when this valve is used. Another special feature of the AC/S2. Pen. is that its construction eliminates background noises. This is a very important factor to be considered in choosing the first detector for a super-heterodyne receiver. The metal coating and the "earth" grid are connected to separate pins in the seven pin base, thus avoiding re-radiation. This valve can also be used as a grid-leak or anode bend detector,



THE AC/HL. DD. is an indirectly heated double diode triode for use in automatic volume control circuits. It combines in one bulb the characteristics of the well-known Mazda AC/HL. valve with a specially designed double diode to ensure distortionless rectification of signals. The diode section of the valve is completely screened, ensuring stability in operation.

In addition to use in ordinary automatic volume control circuits, it has been specially designed for use in amplified automatic volume control circuits where great uniformity in characteristics is required from valve to valve, and where the heater insulation must be of a very high order to minimise hum. The leakage current flowing from heater to cathode when 100 volts is applied is only a fraction of a microampere.

The valve may be used as :

- Half or full-wave detector, followed by an amplifier.
- Half or full-wave detector, with triode amplifier, using A.V.C.
- Half-wave detector with delayed A.V.C. and amplifier stage.
- Amplifier delayed A.V.C. with half-wave rectifier.

Some take chances . . .

Others buy



The Safety Valve

Mazda Radio Valves are manufactured in Great Britain for The British Thomson-Houston Co., Ltd., London & Rugby.



THE EDISON SWAN ELECTRIC CO. LTD.
155, CHARING CROSS ROAD, W.C.2.

(12T)

**Superhet Efficiency by
Merely Changing Coils**

MICRION



The Only
**DUST IRON
COIL**

with
**ADJUSTABLE
INDUCTANCE**

(Micrometer ad-
justment on
both medium
and long waves).

**IMPEDANCE TUNING
IS AN
ENTIRELY NEW SYSTEM**

which makes the advent of the "MICRION" Coil a milestone in the progress of radio development; it is the outstanding achievement of 1933/34. By substituting the "MICRION" Coil (or coils) for existing coils, your old set may be brought right up to date and given an almost unbelievable increase in selectivity and range.

PARTICULARLY DOES THIS APPLY TO CONSTRUCTORS WHO HAVE BUILT SETS WITH THE POPULAR AND FAMOUS DUAL RANGE COIL which although in its day giving truly remarkable results,

is now superseded by the "MICRION" Coil, that is designed for modern broadcasting conditions that now render older coils obsolete.

The "MICRION" Coil replaces all existing coils without alteration of the circuit, and thus renders old sets modern without costly and difficult alterations to the circuit and calibration

List No. B.Y. 36, Actual size,
2 3/4 ins. diameter, 3 ins. high.

SUPERHET EFFICIENCY for
Ask your dealer for "MICRION" Folder.

12/6



Radio Instruments Ltd., Croydon, Surrey. 'Phone: Thornton Heath 3213

Mention of "The Wireless World," when writing to advertisers, will ensure prompt attention.

CHOSEN

**FOR ITS MUSICAL QUALITY
AND EXTREME
SENSITIVITY**

Everything that a perfect pick-up should be, because it is designed on the best musical as well as the best electrical principles.

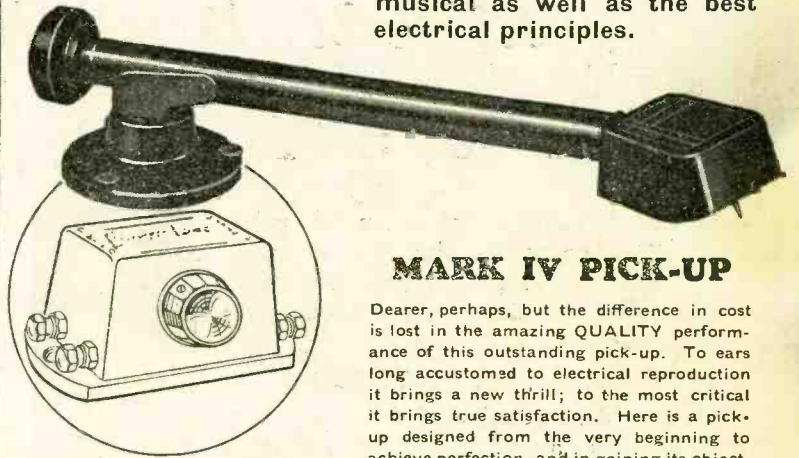

MARK IV PICK-UP

Dearer, perhaps, but the difference in cost is lost in the amazing QUALITY performance of this outstanding pick-up. To ears long accustomed to electrical reproduction it brings a new thrill; to the most critical it brings true satisfaction. Here is a pick-up designed from the very beginning to achieve perfection, and in gaining its object, the BOWYER-LOWE MARK IV Pick-up has won unstinted praise everywhere. This is the pick-up to use if you value QUALITY.

**COMBINED TONE AND
VOLUME CONTROL**
affords separate and perfect adjustment of volume and tone. Is indispensable to users of Bowyer-Lowe and all pick-ups. In bakelite case. Connects in an instant.

10/-

Matched Response Pick-up (rotating head) with swivel arm on ball bearings, base and support. In Florentine bronze and brown Bakelite to match

42/-

In cases of difficulty send direct with name of your usual Dealer. Also for Lists.
BOWYER-LOWE & A.E.D. LTD., DIAMOND WORKS, BRIGHTON

8 meters in one!

There is no other radio testing instrument in the world like the Pifco Rotameter. Eight separate dials, with only one indicator needle. Makes 100 tests in a few minutes. The greatest boon ever offered to radio users. Tests any radio set—battery or electric. A British invention, made in England.

Ask your dealer about it or write direct to:

PIFCO, LTD.
High Street,
MANCHESTER, and
150, Charing Cross Rd.,
London, W.C.2.

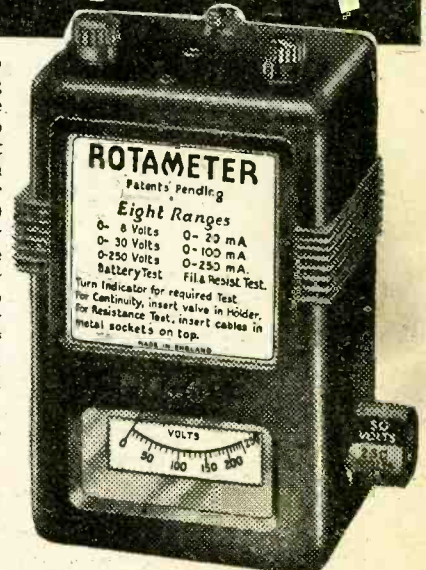

**PIFCO
ROTAMETER**

Price complete
29/6

the new

G.E.C. H.T.

with the

**STABILISED ELECTROLYTE
PURITY • POWER • LONGER LIFE**

**120 volt • 144,000 milliwatt hours
GUARANTEED**

PRICES : 60v : 5/6. 99v : 9/- . 108v : 10/- . 120v : 11/- . 150v : 14/- . 60v. Triple Capacity : 12/- .

ASK FOR
G.E.C. H.T.
TO-DAY

Sold by all
Wireless Dealers.



**MADE IN
ENGLAND**

A TRIAL MEANS YOU'LL ALWAYS USE G.E.C. H.T.

Advt. of The General Electric Co. Ltd., Magnet House, Kingsway, London, W.C.2

Advertisements for "The Wireless World" are only accepted from firms we believe to be thoroughly reliable.

RADIO
IGRANIC
DEVICES

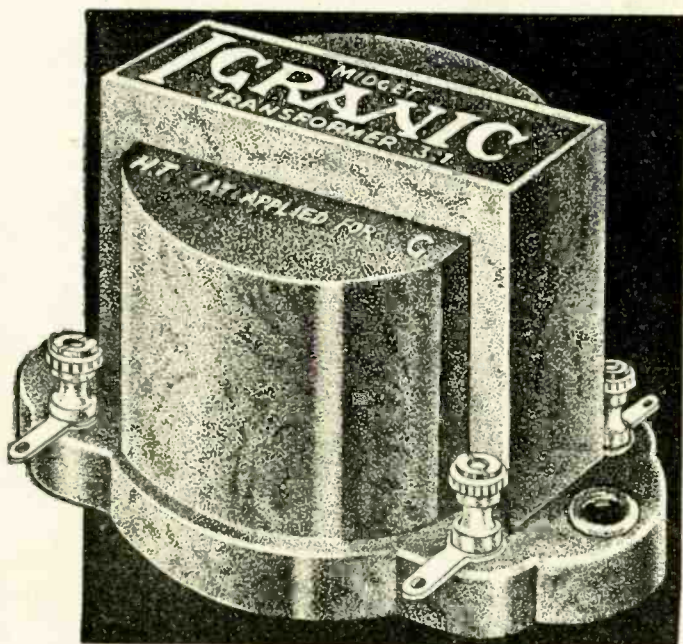

A Transformer I purchased in February, 1925 is still in constant use and as good as ever . . . My slogan after all these years is "Once a user of Igranic, always a user of Igranic."
"Igranic Enthusiast," Leyland, Lancs.

IGRANIC MIDGET TRANSFORMER

Igranic have specialised in Transformer manufacture since the inception of Broadcasting, and many years of experience and costly research has lead to the production of the "Midget" Transformer—unsurpassed for quality and performance. This wonderful Transformer renders the highest standard of tonal purity without a trace of "drumming." Its production reaches a standard never previously attained by a Transformer of such reasonable price. Supplied in ratios 3-1 and 5-1. Price **8/6**

Write for fully illustrated Catalogue No. U.356 of Igranic Quality components.

Igranic Electric Co. Ltd., 149, Queen Victoria St., E.C.4.

IGRANIC COMPONENTS WILL BE THE MAKING OF YOUR SET

CVS—55

The Laboratory Tested
FARADAY ALLWAVE SUPER
All Sets Suitable for Tropical Use.

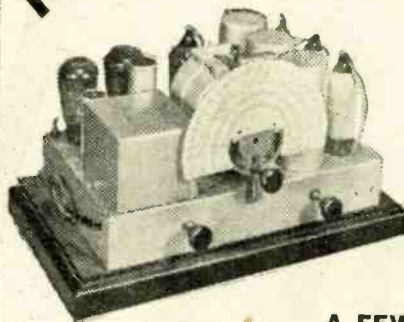

- Considerable fluctuations of mains voltage do NOT affect tuning.
- The Superhet, with automatic volume control on short, medium and long waves.
- Each set is tested INDIVIDUALLY on reception of American station IN DAYLIGHT.
- A separate scale is used for each waveband and calibrated in wavelengths, operated by ONE Tuning Knob.

A FEW POINTS OF INTEREST:—

- (1) Full Calibration, which remains constant.
- (2) Fitted with Mains Aerial and with sockets for Gramophone Pick-up.
- (3) Distortionless volume control is incorporated with the Mains Switch on both radio and gramophone.
- (4) The wavechange switch has an electrical device which automatically throws a strip of light on to the actual working sector of the dial scale in the wave band selected.
- (5) A TONE FILTER to enable you to reduce atmospheric interference on bad days.
- (6) Energised Moving Coil Speaker. Provision for extra speaker, by request only, at extra charge.
- (7) Indirectly heated Rectifier—Electrolytic smoothing condensers.

CERTAIN TERRITORIES ARE STILL OPEN FOR AGENCIES. APPLICATION SHOULD BE MADE AT ONCE.

FARADAY ALLWAVE WIRELESS
1, SALCOTT ROAD, LONDON, S.W.11. Phone: Battersea 2085

EXIT INTERFERENCE!

The Radioformer

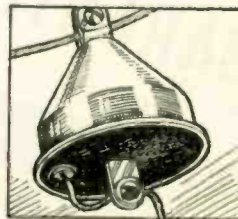

'RADIOFORMER'

TYPE A. Top groove clamps aerial securely, while lead-in fits under washer in base and passes down to 'Radioformer.'

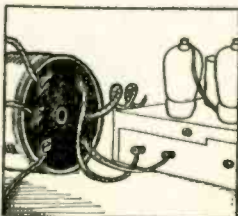

'RADIOFORMER'

TYPE S. Fitted to Set.

The **RADIOFORMER** eliminates "static" when the set is tuned to a station. Many sets fitted with A.V.C. become extremely sensitive between stations, and pick up a great deal of noise. The so-called interference suppressors are fitted to reduce this noise between stations whereas the **RADIOFORMER** reduces the noise which interferes with pure reception of a station.
Pat. applied for.

removes the greatest bugbear of wireless reception—man-made Static. By fitting the Radioformer, a perfectly simple job, interference caused by electrical apparatus can be immediately and definitely stopped. Consisting of the Aerial and Set Radioformers, with 50 feet of shielded down lead, the kit will make a world of difference to the reception of any set on wavelengths from 15 to 550 metres,

and with only the slightest weakening of the less powerful signals on the long waves.

17/6

Complete, post free.

SINGLE UNITS

Aerial Transformer	
Type A.	7/6
Set Transformer	
Type S.	7/6
Shielded Cable, 50 ft.	4/6
Ditto 100 ft.	8/6

The RADIOFORMER
BRITISH MADE

Terms to the trade supplied on application to the Sole Manufacturers:—
RADIOFORMER LTD., York Works, Browning Street, LONDON, S.E.17.
Tel: Rodney 3573.

**The Senior
WEARITE-NUCLEON
IRON CORE COIL**

12/6

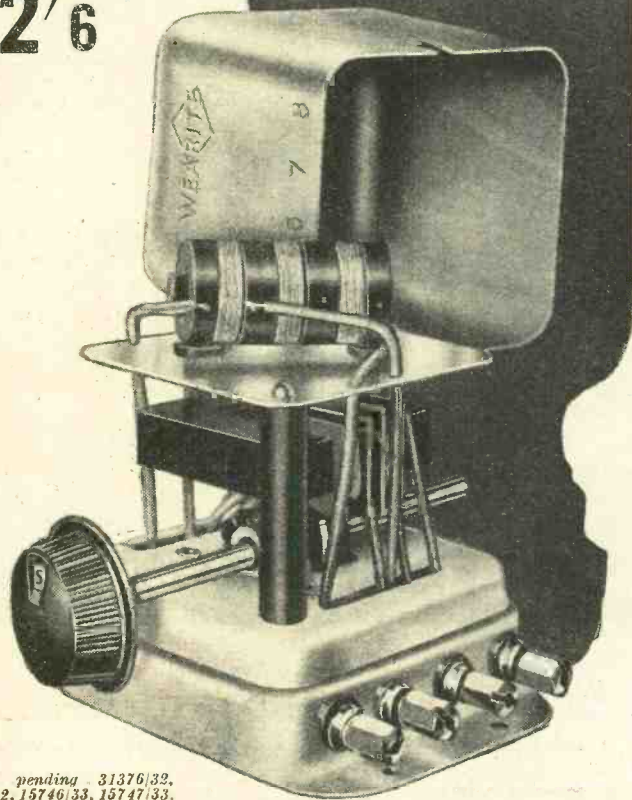

Patents pending 31376/32,
31377/32, 15746/33, 15747/33.
Pending Registration Trade
Mark 542011.

**FROM THE DESIGNER'S
SPECIFICATION SHEET**

- One Wearite Nucleon B.P.1. Coil..... **12/6**
- One Wearite Nucleon B.P.2. Coil..... **12/6**
- One Wearite Nucleon T.G. Coil..... **12/6**
- One Wearite H.F. Choke (with pigtail)
H.F.P.A. **4/-**

- One Wearite H.F.
Choke (without pig-
tail) H.F.P..... **3/6**

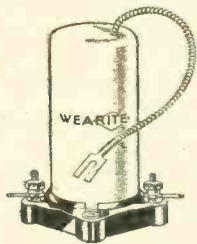

The Following

components of the Wearite range are suitable for inclusion in the A.V.C. Three — and are according to designer's specification.

- One Wearite Mains Transformer B.W.W. **27/6**
- One Wearite Mains Choke H.T.35..... **10/6**

SEND FOR YOUR COPY

of the new Wearite Booklet and for the Full-size Blue Print with constructional details for building the "WEARITE-TEAMSTER" 4 VALVE RECEIVER. Use this Coupon . . .

WEARITE
Reg. Trade Mark

NUCLEON
IRON CORE COILS

are Specified for the

A.V.C. THREE

A.V.C. is made possible in this up-to-date receiver because of the good signal strength initially obtained. In other words, because of the efficiency of its tuning circuit—of the use of Nucleon Iron Coils. Permitting an extremely high degree of selectivity, permitting the valves to make the best use of their characteristics, Nucleon Iron Core Coils become an essential to the perfect functioning of the A.V.C. Three—Make sure of your results—follow the designer.

WRIGHT & WEAIRE LTD.,
740, High Road, Tottenham, N.17.

Telephone: Tottenham 3847/8.

Listen!

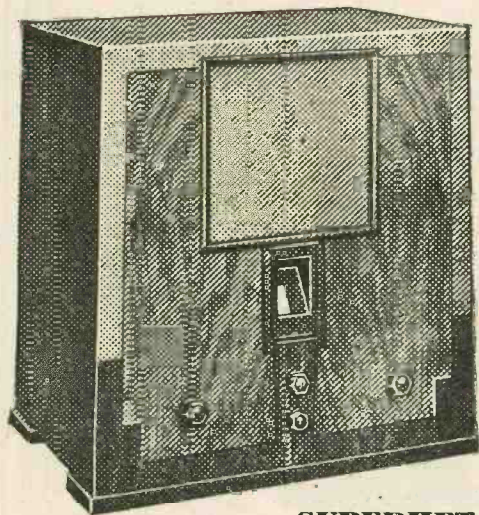

**SUPERHET
CONCERT SEVEN**

Electrically operated, for A.C. mains. Super-heterodyne circuit employing variable mu valves. Seven Marconi valves (including rectifier). Delayed automatic volume control. Mush and static suppressor. Duplex tone control. Adjacent channel selectivity. Energised moving coil speaker. Optically magnified illuminated scale. Modern cabinet of finely figured woods.

MODEL 467 **Price 22 Gns.** Or by Hire Purchase.

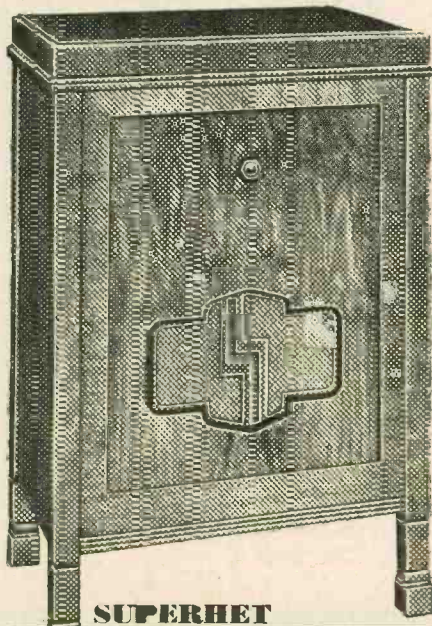

SUPERHET



OF RADIO SETS TO-DAY THERE IS NO END. Moreover, most people defend the particular set they own with such fervour that you would think personal honour involved. All this makes things the more difficult for a listener choosing his new set. He wants absolutely disinterested advice. And when you come to think of it, what more severe and incorruptible critic could there be than the dog? He has no set to defend, and consummate indeed must be the realism which persuades him to hear his master's voice from anything but his master's lips!

Just that consummate realism in sound reproduction has been the aim of "His Master's Voice" for more than thirty years. Hence the famous trademark: the severest critic *listens*—and is deceived. To-day you are invited to *listen*—just listen—and be convinced. At the same time you will appreciate why "His Master's Voice" is, besides being the world's most famous trademark, the surest guide to the distracted radio purchaser of to-day. Full particulars of radio bearing this insignia can be obtained from any authorised dealer or from "HIS MASTER'S VOICE," 98 (Dept. W), Clerkenwell Road, London, E.C.1.

"His Master's Voice"
"TRUE - TO - LIFE"
RADIO

Phone Co., Ltd., 98 (Dept. W), Clerkenwell Road, London, E.C. 1

(Prices do not apply in I.F.S.)

Mention of "The Wireless World," when writing to advertisers, will ensure prompt attention.

The Wireless World

THE
PRACTICAL RADIO
JOURNAL
23rd Year of Publication

No. 737.

FRIDAY, OCTOBER 13TH, 1933.

VOL. XXXIII. No. 15.

Proprietors: ILIFFE & SONS LTD.

Editor:
HUGH S. POCKOCK.

Editorial,
Advertising and Publishing Offices:
DORSET HOUSE, STAMFORD STREET,
LONDON, S.E.1.

Telephone: Hop 3333 (50 lines).
Telegrams: "Ethaworld, Watloo, London."

COVENTRY: Hertford Street.

Telegrams: "Cyclist, Coventry." Telephone: 5210 Coventry.

BIRMINGHAM:

Guildhall Buildings, Navigation Street, 2.
Telegrams: "Autopress, Birmingham." Telephone: 2970 Midland (3 lines).

MANCHESTER: 260, Deansgate, 3.

Telegrams: "Iliffe, Manchester." Telephone: Blackfriars 4412 (4 lines).

GLASGOW: 26B, Renfield Street, C.2.

Telegrams: "Iliffe, Glasgow." Telephone: Central 4857.

PUBLISHED WEEKLY. ENTERED AS SECOND
CLASS MATTER AT NEW YORK, N.Y.

Subscription Rates:

Home, £1 1s. 8d.; Canada, £1 1s. 8d.; other
countries abroad, £1 3s. 10d. per annum.

*As many of the circuits and apparatus described in these
pages are covered by patents, readers are advised, before
making use of them, to satisfy themselves that they would
not be infringing patents.*

CONTENTS

	Page
Editorial Comment	297
A.V.C. Three	298
Television Progress	302
FOREIGN PROGRAMME	
SUPPLEMENT, pp. I—XXIV	
Practical Hints and Tips	305
Radio Luxembourg	306
Visual Tuning Indicator	307
News of the Week	308
Broadcast Brevities	309
Letters to the Editor	310
Ferranti "Lancastria" Superhet	311
New Apparatus Reviewed	312

EDITORIAL COMMENT

Common Waves

Limitations of the Scheme

NOW that London National and West Regional transmitters have for some time been operating on a common wavelength of 261.6 metres, the opportunity has been provided for forming an opinion as to the value of a synchronising system of this nature as a compromise to assist in overcoming the troubles of wavelength congestion in Europe.

It does not appear that the B.B.C. has any intention of continuing this twin wavelength arrangement permanently, for under their present plan, as soon as Droitwich is ready to operate as the new long-wave National transmitter, most of the remaining stations in different parts of the country will give Regional programmes alternative to the National, and the present medium-wave National programmes will cease.

This technical experiment of synchronising the London National and West Regional has been interesting, if only because it has proved to the satisfaction of most listeners, and we hope to broadcasting authorities in general, that such a scheme has very little to recommend it. The B.B.C. frankly admits that anywhere outside a reliable service range of these transmitters, which they put at approximately 40 to 50 miles, common-wave interference occurs. This interference takes the form of a beat, which so chops the reproduction that in the case of speech it gives the impression that the speaker is stuttering. These two stations, therefore, which under normal conditions (if they had wavebands to themselves) would have an after-sunset range which we may conservatively place at 200 miles, can now serve no more than a local area.

Common wavelength schemes of this nature would, it appears, prove worth while only where stations are very widely spaced geographically and where it is not desired that either of them should serve listeners at any distance. It would not matter, for instance, if an English station were synchronised with another in Russia, so long as it was not desired that either should be intelligible beyond its own national boundary.

Little is to be gained if, in the process of saving one wave channel, the area covered by each station is reduced to approximately one sixteenth of what might be expected of it after sunset, yet this is what does actually occur.

It is useless for the B.B.C. to regard the service area of a station as only some fifty miles radius, for if that were accepted our B.B.C. stations would fall very far short of serving the total area of the country.

The A.V.C. Three

A Receiver of Unusual Performance

HITHERTO the advantages of automatic volume control have been generally available only to owners of sets of the super-heterodyne class, or straight sets having two high frequency stages. The receiver described in this issue should, therefore, be of very special interest to our readers, as although there is only one H.F. stage, delayed amplified automatic volume control is incorporated, whilst at the same time retaining reaction.

The three-valve set is undoubtedly the most popular type of all, and now, with the addition of automatic volume control, we anticipate that this set will make a strong appeal and give excellent service in the coming winter, the automatic volume control increasing still further the interest in distant reception.

"The Wireless World"

A.V.C. Three

A Selective Three-Valve A.C. Mains Receiver with Automatic Volume Control

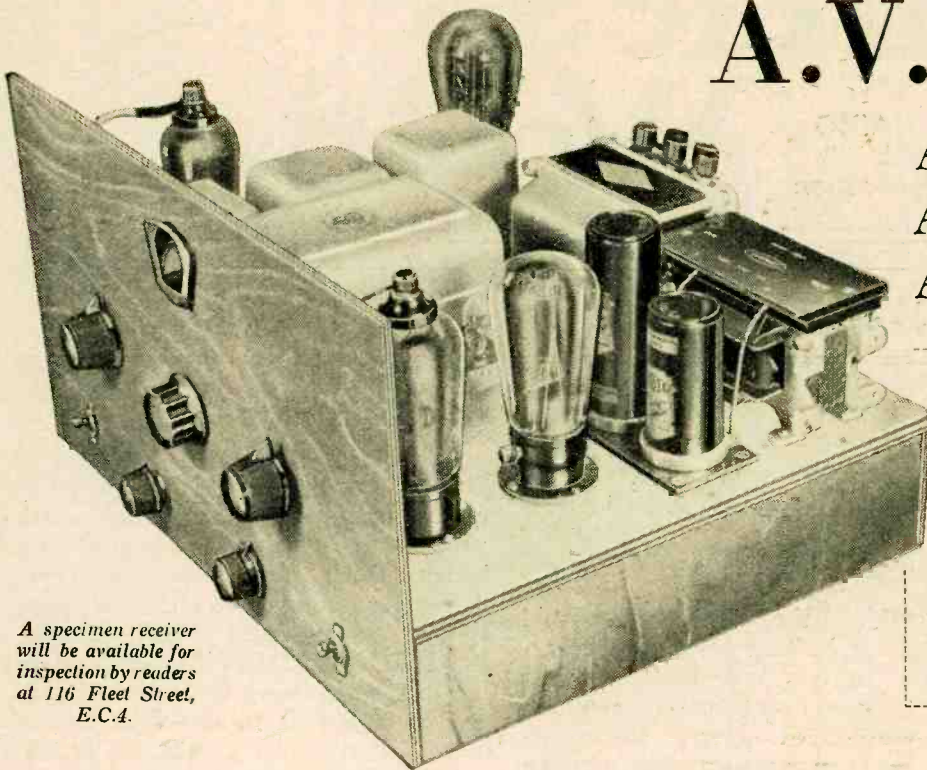

A specimen receiver will be available for inspection by readers at 116 Fleet Street, E.C.4.

DELAYED amplified A.V.C. is a form of automatic volume control which lends itself particularly well to use in the smaller class of receiver where a moderate detector input and reaction are both necessities. "The Wireless World" A.V.C. Three for the first time combines delayed amplified A.V.C. with reaction and so represents a step forward in that the disadvantages of fading with the smaller class of receiver are reduced.

THE three-valve receiver still deservedly retains its popularity, for when it is used with a good aerial it is capable of bringing in the more powerful of distant stations at good volume, while the quality of reproduction can be very satisfying. Moreover, the introduction of iron-core type tuning coils has led to such an increase in the selectivity obtainable that good results in distant reception are now possible even at short distances from the local station.

In the past, automatic volume control has not been applied with any great success to a receiver of this nature, since

the systems available either led to an inadequate control or prohibited the use of reaction, without which the maximum sensitivity is likely to be inadequate. It is possible, however, to modify the amplified A.V.C. circuit in such a manner that both good A.V.C. and reaction are obtainable.

The circuit diagram of the new receiver is shown in Fig. 1, and it will be seen that the H.F. valve, which is of the screened H.F. pentode type, is preceded by a band-pass filter employing iron-core coils. The filter coupling is of the mixed capacity type, the lower capacity being the 0.05 mfd. condenser C2 and the upper the

condenser C1. The coupling between the H.F. and detector stages is by means of a shunt-fed transformer to which reaction is applied. The primary of the transformer is fed by means of the screened H.F. choke Ch1 and the 0.0005 mfd. condenser C5, and the tuned circuit itself is connected through the 0.001 mfd. condenser C6 to one diode of the duo-diode-triode valve which provides signal rectification, L.F. amplification, reaction, and delayed A.V.C. When the switch S2 is in the upper position on the diagram, the 0.25 meg. resistance R7 is connected between the diode anode and cathode, and it acts as the diode load resistance, and is analogous to the grid leak of an ordinary detector. There are developed across this resistance H.F. potentials due to the sig-

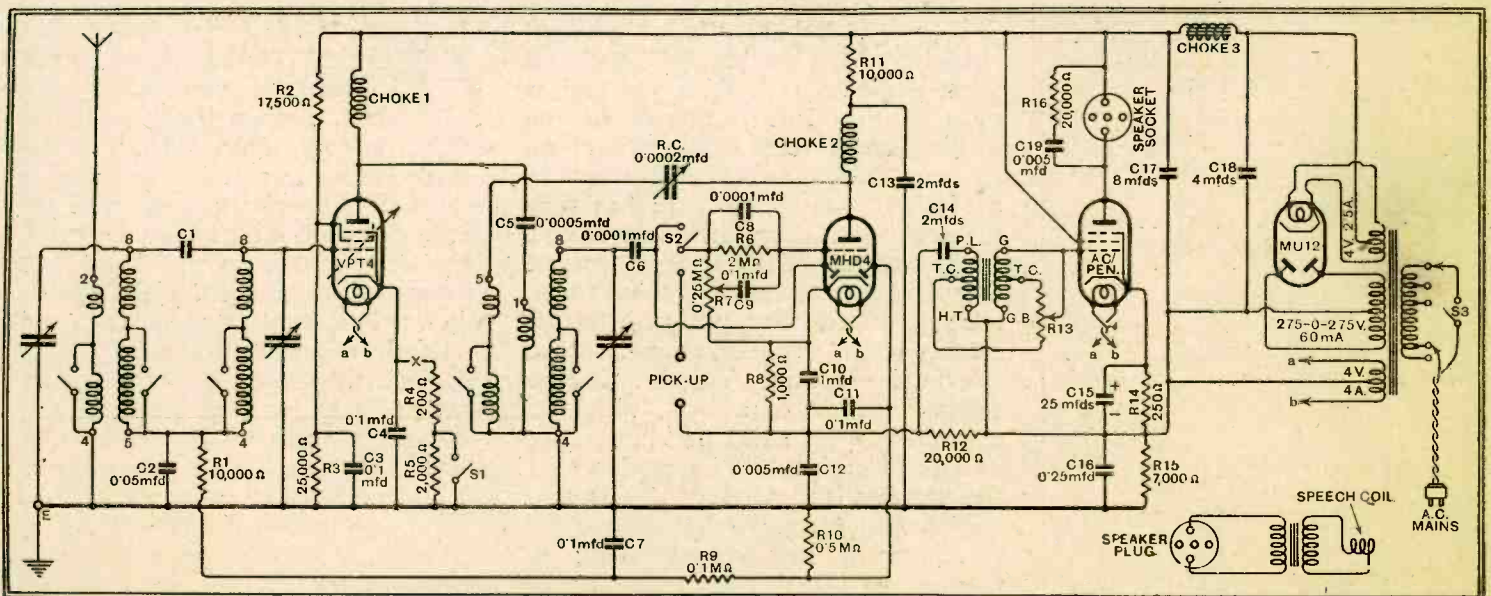
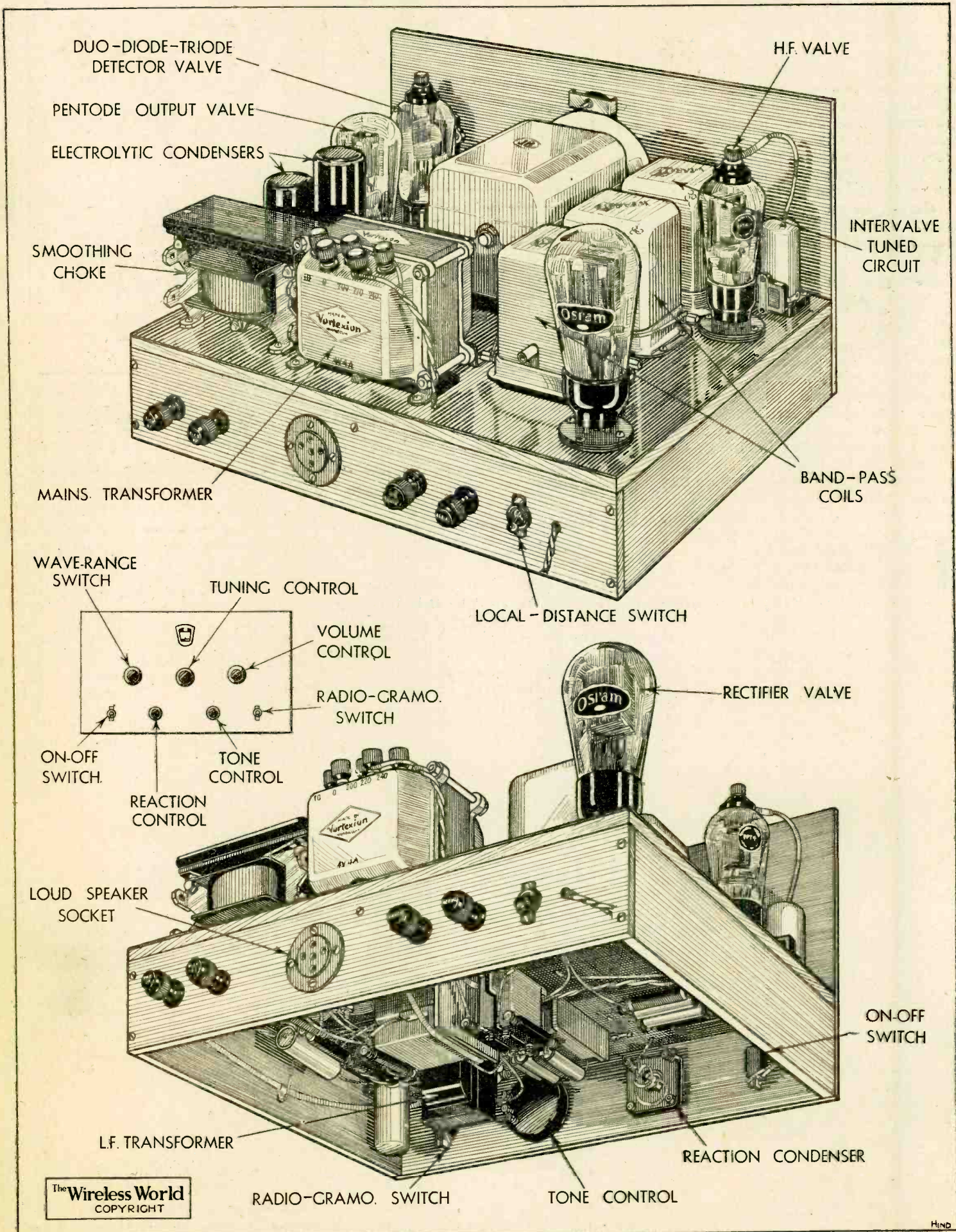

Fig. 1.—The complete circuit diagram shows that delayed amplified A.V.C. is obtained with the duo-diode-triode valve, and that this also serves to give signal rectification, L.F. amplification and reaction. The potentiometer R7 acts as the manual volume control and is operative on both radio and gramophone.

The Chassis of the New A.V.C. Set



The positions of the chief components can readily be seen in these drawings of *The Wireless World* A.V.C. Three, and it will be noted that the layout adopted is one leading to a straightforward assembly and easy wiring.

"The Wireless World" A.V.C. Three—
 nal, with L.F. and D.C. potentials due to its rectification. The latter two are applied to the triode grid in the usual way through the condenser C9 of 0.1 mfd. and the 2 megohms resistance R6, the connection of C9 being made to the slider of the resistance R7, for this serves as the manual volume control as well as the diode load resistance. The H.F. potentials are applied to the triode grid through the 0.001 mfd. condenser C8, which shunts R6. On gramophone, S2 is in the lower position on the circuit, and the pick-up is returned to the cathode through the biasing resistance R8 of 1,000 ohms shunted by the 1 mfd. condenser C10.

The A.V.C. Circuit

In the anode cathode circuit of the triode, therefore, there appear H.F. currents, L.F. currents, and a change of direct current upon the application of a signal. The H.F. currents perform their useful function in the anode circuit, and are deflected through the reaction condenser R.C. to the reaction coil by the H.F. choke Ch2. Decoupling from L.F. currents in the H.T. supply is obtained with the aid of the 10,000 ohms resistance R11 and the 2 mfd. condenser C13. The H.F. currents are not required in the cathode circuit, and are consequently by-passed by the 0.005 mfd. condenser C12.

The load resistance to L.F. currents is in the cathode circuit, and consists of the 20,000 ohms resistance R12, from which the primary of the L.F. transformer is shunted through the 2 mfd. condenser C14. Now it will be observed that the resistance R12 is returned directly to negative H.T., whereas the earth line of the set, to which the H.F. valve cathode circuit is returned, is connected to negative H.T. through the

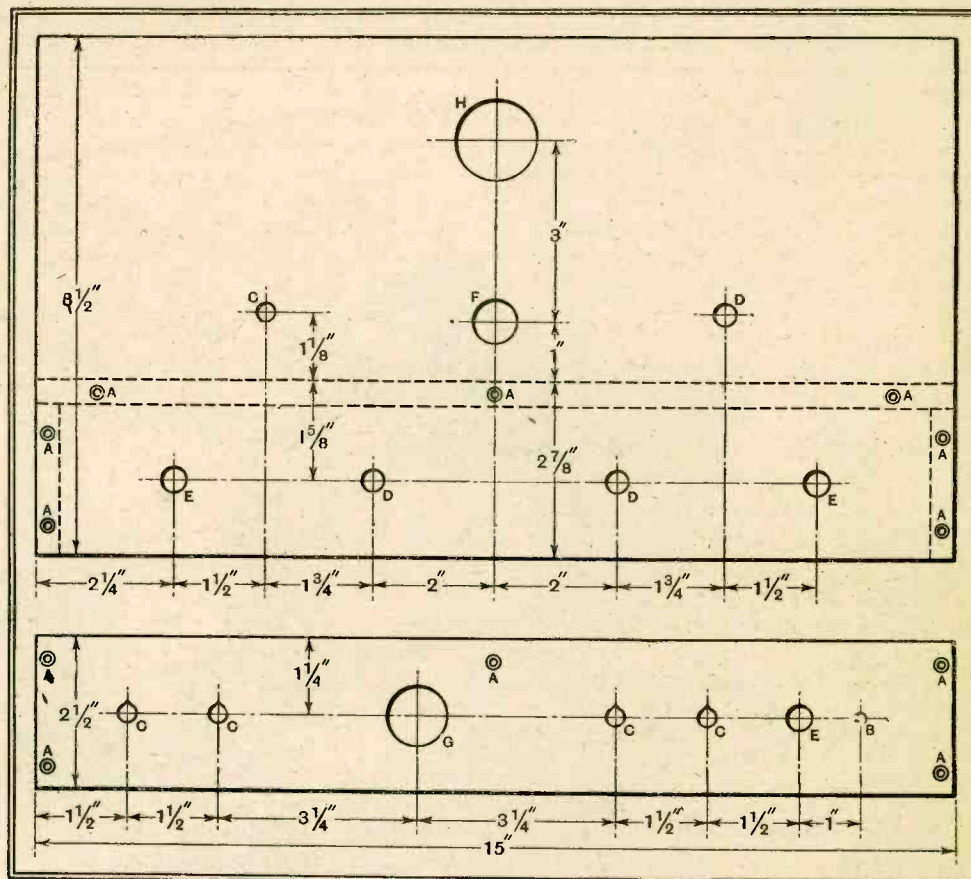

7,000 ohms resistance R15 shunted by the 0.25 mfd. condenser C16. The cathode of the H.F. valve, therefore, is positive with respect to negative H.T. by the drop across R15. With no applied signal the voltage drop across R12 is greater than that across R15, so that the MHD4 cathode is more positive than the H.F. valve cathode, and is consequently positive with respect to

the earth line. Now the grid of the H.F. valve is returned to the earth line through the 10,000 ohms resistance R1, the 100,000 ohms resistance R9, and the 500,000 ohms resistance R10, the condensers C7 and C11 serving as by-pass capacities. R10 is also connected to the second diode anode, but as the cathode is positive with respect to the earth line, the anode is negative with respect to the cathode, and is non-conductive. There is thus no current flow through any of the resistances included in the H.F. valve grid circuit, and the grid potential of this stage is consequently only that provided by the minimum bias resistance R4, assuming the switch S1 to be closed.

When a signal is applied the triode grid is negatively biased as a result of rectification, and the triode anode current drops. The triode cathode becomes less positive, therefore, and if the signal be strong enough the drop across R12 becomes less than that across R15 and the cathode is then negative with respect to the earth line. The second diode anode, therefore, is positive with respect to the cathode, and it becomes conductive and assumes practically the same potential as the cathode. For all practical purposes the grid of the H.F. valve may be considered as following the potential of the triode cathode, since it is connected to it through a series of resistances, and the diode-cathode path of the valve. As the signal increases in strength, so the triode cathode becomes more and more negative with respect to the earth line, and the H.F. valve grid follows it and becomes increasingly biased negatively, thus reducing its amplification.

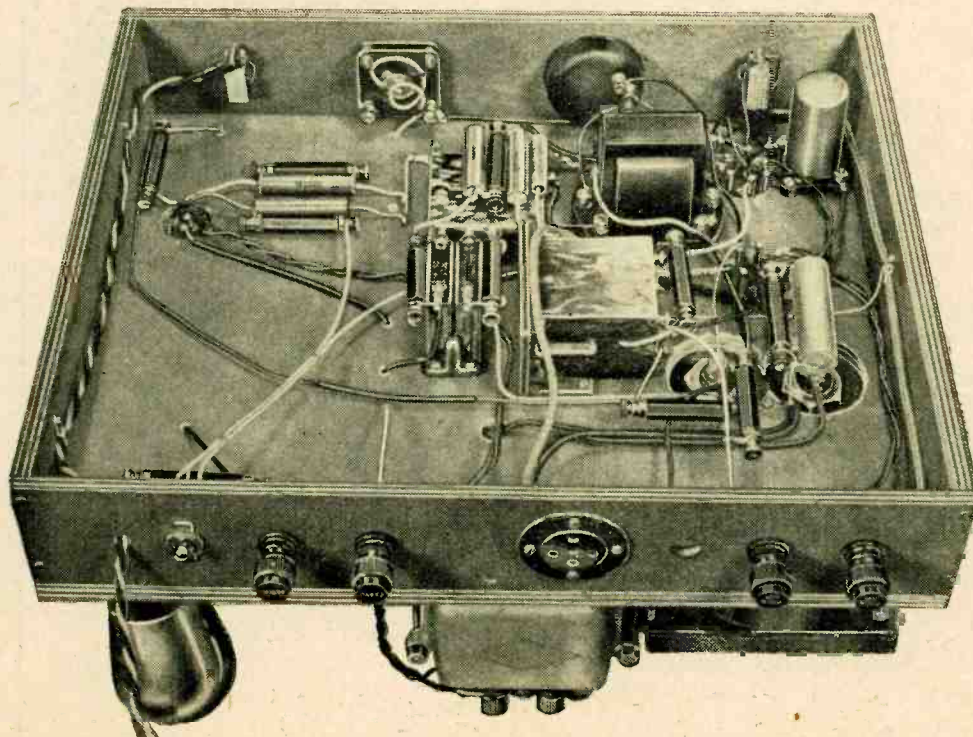

An under-baseboard view of the receiver showing the by-pass condensers and the voltage dropping resistances.

"The Wireless World" A.V.C. Three—

At first glance the arrangement appears somewhat complicated, but it is essentially simple and straightforward in operation, and the rest of the set follows normal practice. The L.F. transformer secondary feeds the control grid of the output pentode, which is of the indirectly heated type rated for an output of about 2½ watts. The cathode is returned to negative H.T. through the 250 ohms bias resistance R14 shunted by the 25 mfd. electrolytic condenser C15; the full H.T. voltage of about

250 volts is thus applied to the output valve. The mains equipment consists of the usual mains transformer with a full-wave rectifier valve and a single smoothing choke Ch3 operating in conjunction with the electrolytic condensers C18 and C17 of 4 mfd. and 8 mfd. respectively.

The three receiver valves are all of the indirectly heated type; in order to avoid an excessive voltage rise on switching on without employing a delay action switch, therefore, the rectifier valve is one of the new indirectly heated types, the MU.12.
(To be concluded.)

- Wood panel, ½-ply, 15in. x 8½in.
- Plymar Baseboard, 12in. x 15in. x ½in. Peto-Scott
- 2oz. No. 20 tinned copper wire, 6 lengths Systollex, Wire, Wood, Paxolin, Flex, etc.
- Screws: 10 ¼in. No. 4 R/hd., 18 ½in. No. 4 C/sk., 36 ¾in. No. 4 R/hd., 1 6BA 1 in R/hd. with nut and washers.
- Valves:—1 Osram or Marconi MHD4, 1 Osram or Marconi MU12, 1 Mazda AC/Pen., 1 Ferranti VPT4, or Mullard VP4.

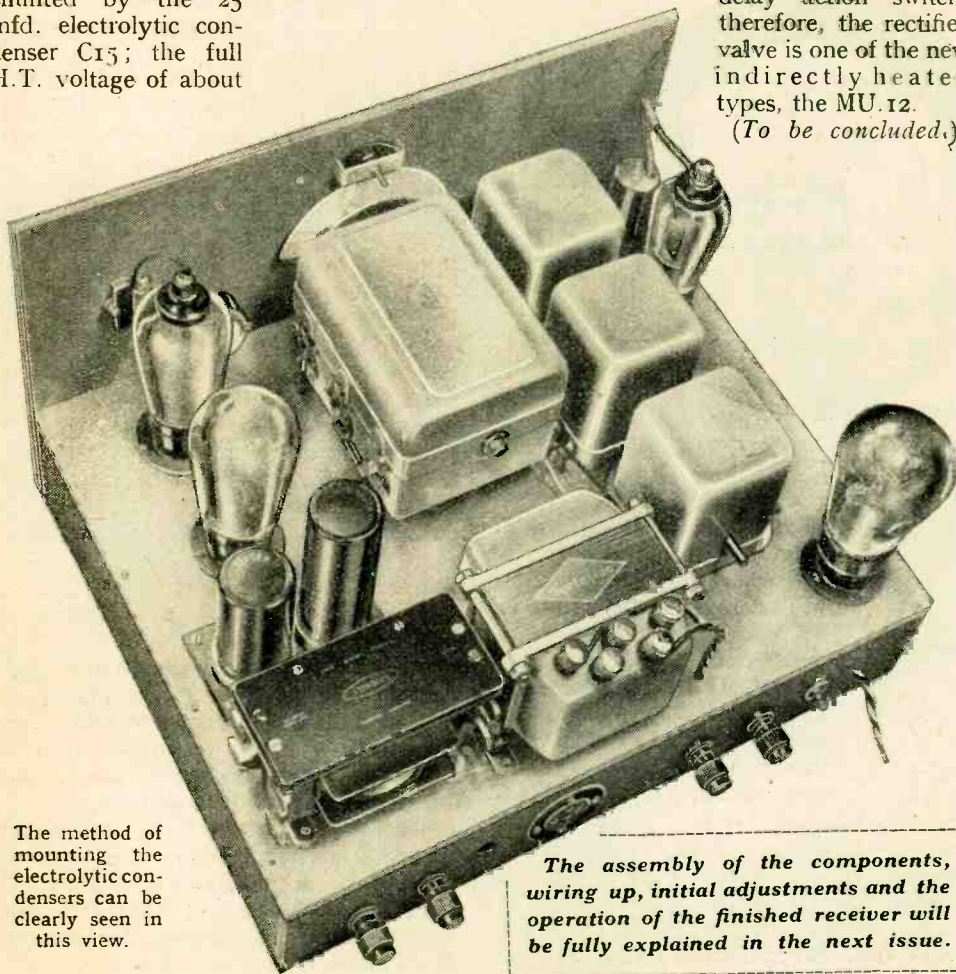

The method of mounting the electrolytic condensers can be clearly seen in this view.

The assembly of the components, wiring up, initial adjustments and the operation of the finished receiver will be fully explained in the next issue.

THE LIST OF PARTS

After the particular make of component used in the original model, suitable alternative products are given in some instances.

- 1 3-gang Variable condenser and disc drive J.B. "Nugang" No. 2064 (British Radiophone, Polar.)
- 1 Variable Condenser, 0.0002 mfd., R.C. Ormond R/507
- 1 Knob for above Ormond R/355
- 1 Iron core coil Wearite "Nucleon" B.P.1
- 1 Iron core coil Wearite "Nucleon" B.P.2
- 1 Iron core coil Wearite "Nucleon" T.C. (Colvern, Varley.)
- 1 Transformer Multitons "Toco" 1:4
- 1 Tone control potentiometer for use with above, R13 Multitons
- 1 Volume control potentiometer, 250,000 ohms, tapered. R7 Watmel T4 (Claude Lyons, Magnum, Rothermel.)
- 1 H.F. choke, Ch2 Wearite HFP
- 1 H.F. choke, Ch1 Wearite HFPA (Kinva, McMichael.)
- 1 Power smoothing choke, 30 henrys 50 m.a., Ch3 Davenset No. 101 (R.I., Sound Sales, Varley.)
- 1 Mains transformer, 200 to 250 volts, 50 cycles Secondaries: 275-0-275 volts, 4 volts, 2.5 amps centre-tapped, 4 volts 4 amps, centre-tapped. Vortexion A.C.34 (British Radio Gramophone Co., Bryce, Challis, Davenset, Claude Lyons, Sound Sales.)
- 4 5-pin Valve holders Clix Chassis Mounting Air Sprung Type Clix Floating Type (W.B.)
- 1 7-pin Valve holder Clix Floating Type
- 2 Fixed condensers, 0.0001 mfd., C6, C8 Telsen W.207
- 1 Fixed condenser, 0.0005 mfd., C5 Telsen W.211
- 1 Fixed condenser, 0.25 mfd. 500v. D.C. test, C16 Telsen W.229
- 1 Fixed condenser, 0.05 mfd. 500v. D.C. test, C2 Telsen
- 1 Fixed condenser, 1 mfd. 500v. D.C. test, C10 Telsen W.227
- 2 Fixed condensers, 2 mfd., 500v. D.C. test, C13, C14 Telsen W.226
- 5 Tubular condensers, 0.1 mfd. 1,500v. D.C. test, C3, C4, C7, C9, C11 Telsen W.411
- 2 Tubular condensers, 0.005 mfd. 1,500v. D.C. test, C12, C19 Telsen W.408 (Graham Farish.)
- 1 Dry electrolytic condenser, 4 mfd., 500 working peak voltage C18 Telsen W.396
- 1 Dry electrolytic condenser, 8 mfd., 500 working peak voltage C17 Telsen W.398
- 1 Dry electrolytic condenser, 25 mfd., 25 volts, C15 Telsen W.399 (Dubilier, Peak, T.C.C.)
- 1 Resistance, 200 ohms, R4 Graham Farish Ohmite 1½ Watts Type
- 1 Resistance, 250 ohms, R14 ditto
- 1 Resistance, 1,000 ohms, R8 ditto
- 1 Resistance, 2,600 ohms, R5 ditto
- 1 Resistance, 7,000 ohms, R15 ditto
- 2 Resistance, 10,000 ohms, R1, R11 ditto
- 1 Resistance, 17,500 ohms, R2 ditto
- 2 Resistance, 20,000 ohms, R12, R16 ditto
- 1 Resistance, 25,000 ohms, R3 ditto
- 1 Resistance, 100,000 ohms, R9 ditto (Dubilier, Eric. Claude Lyons, Ready Radio, Varley.)
- 1 Grid leak, 2 megohms, R6
- 1 Grid leak, 0.5 megohm, R10 ditto (Dubilier, Eric. Claude Lyons, Ready Radio, Varley.)
- 2 Switches, on-off, S1, S3 Claude Lyons 728
- 1 Switch single-pole change-over, S2 Claude Lyons 729 (British Radiophone, Bulgin.)
- 1 5-pin plug Bulgin P.3 (British Radio Gramophone Co.)
- 1 Length screened sleeving Harbros
- 4 Ebonite shrouded terminals, A., E., Pick up (2) Belling-Lee Type B

The Wireless World Diary for 1934

THE popular esteem in which previous editions of our Diary has been held was shown by the speed with which the issue has been sold out in past years. It is hoped that the new Diary for 1934 will find equal favour.

Those regular features which experience has shown to be most generally useful have been retained and brought up to date. The list of broadcasting stations in Europe and Northern Africa is given in accordance with the Lucerne Plan, which comes into force on January 15th, 1934.

A new feature which will appeal to all set-users is the Receiver Maintenance Records, in which particulars of battery renewals and technical notes, including valve anode currents, can be recorded.

The Useful Formulæ have been revised, and a new Abac provided for calculating decibels. The Circuit Diagram section has been retained with many new diagrams of receivers and accessories, including a short-wave superheterodyne converter and anti-interference filters and suppressing devices.

The Valve Data section now occupies thirteen pages, and gives the fullest practical information on all the modern valves.

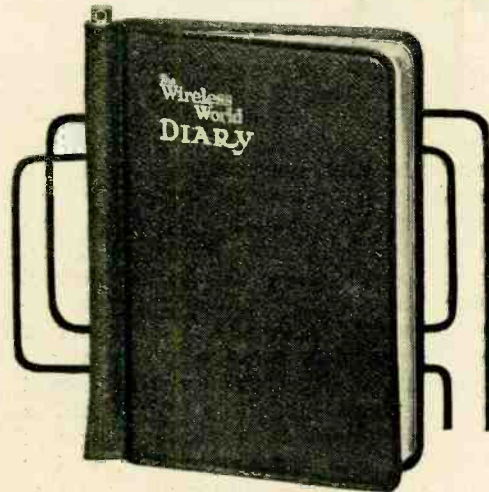

The Diary, comprising 192 pages, is obtainable from all booksellers, stationers, and bookstalls, or direct from the publishers. Price 1s. 6d., or by post 1s. 7d.

THE OLYMPIA CAR DISPLAY

YESTERDAY the great International Auto-mobile Exhibition opened at Olympia. While car radio in this country has as yet made little progress, there is evidence that it is likely to spring into popularity.

In connection with the Exhibition, which closes on the evening of Saturday, the 21st instant, *The Autocar* is producing three Special Show Numbers. The first issue was dated October 6th, and contained a Buyers' Guide to 1934 models, giving full specifications of all cars on the British market. To-day's issue of *The Autocar* is a complete Show Report, and next week various specially interesting features at the Show will be fully described and illustrated.

Television Progress

Problems of the Next Step

IN considering the possibilities of improving radio transmitting conditions, attention has been focused mainly upon what are known as the ultra-short waves, i.e., those below 8 metres, mainly for reasons arising out of experience in connection with facsimile transmissions on the waves around 50 to 100 metres used

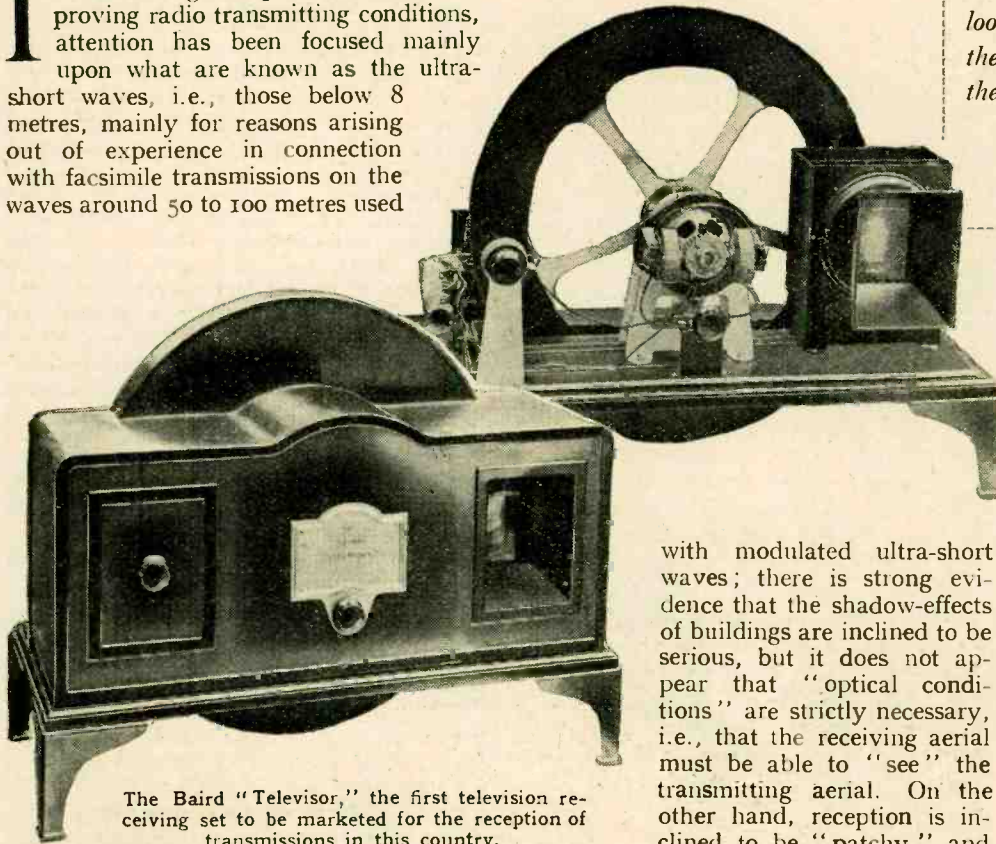

The Baird "Televisor," the first television receiving set to be marketed for the reception of transmissions in this country.

for transcontinental traffic. It is, of course, well known that the latter waves depend for their long-range qualities upon reflections from the Heaviside layer, which, while giving rise to no harmful effects on telegraphic and telephonic circuits, result in confusion of a greater or less degree when visual subject matter is transmitted. Trouble as a consequence of such "echoes" has been experienced in the transmission of facsimile images at relatively low scanning speeds, and it appears to be generally considered that television on these wavelengths would be subject to far greater interference and would thus be impossible in practice.

Wavelength and Service Area

When we come to wavelengths below eight metres we arrive at conditions where reflections from the upper atmosphere do not take place. The result of such a state of affairs is that only a more limited area can be effectively served by one broadcasting station, since the waves attenuate very rapidly as the distance from the station increases, but, on the other hand, there is the advantage that "echo" troubles entirely vanish.

Very little information is available as to the problems of serving a given area

with modulated ultra-short waves; there is strong evidence that the shadow-effects of buildings are inclined to be serious, but it does not appear that "optical conditions" are strictly necessary, i.e., that the receiving aerial must be able to "see" the transmitting aerial. On the other hand, reception is inclined to be "patchy," and it seems fairly clear that the erection of ultra-short wave aerials in London will not be the simple business to which ordinary broadcast listeners are accustomed in connection with medium and long wavelengths.

The position in connection with improving the detail of the transmitted picture thus resolves itself into the provision (a) of an optical system which subdivides the picture into a greater number of elements, and (b) of an electrical system, including a radio link, which enables the improved detail to be effectively transmitted. The situation under the former heading necessitates a decision as to what degree of detail is essential to good entertainment value, a question which is comparable in one sense to the case of frequency band width in telephonic transmission, but in another sense stands in strong contrast to it. The decision in the case of telephony makes no difference to the design of receivers, as these can perfectly well ignore the extended frequency range if for any reason they do not want to take advantage of it; the decision in the case of television, however, is binding upon all parties, since the receiving apparatus must operate in synchronism with and in exact conformity to the transmitting apparatus.

Of these two problems the second does not require much further consideration,

***B**EFORE we jump to any conclusions in regard to the imminence of a practical television service on short waves, it is well to look at the problems involved and consider the ways and means available for solving them. These problems are discussed in the following article and an attempt is made to give them their proper perspective in the general television picture.*

since the matter of the radio link is perfectly straightforward, though, paradoxically enough, it may prove the most serious stumbling block. We have to design a transmitter which operates on the ultra-short wavelengths, is capable of being modulated over a frequency range of anything up to 500 kc/s with substantially uniform response, and has an aerial system which efficiently distributes the radiated power. On the receiving side an aerial has to be set up which is an efficient collector, having regard to its location, and the received high frequency waves have to be amplified uniformly over whatever range of frequencies is indicated. The most serious problems are field strength and interference, and it must be borne in mind, of course, that the larger the frequency band being received the greater will be the susceptibility of the apparatus to interference, particularly from the ignition systems of motor cars. The purely technical side of building flat amplifiers does not offer insuperable difficulties, though, of course, an unusually large number of stages of amplification may be required.

Short Wave Interference

Having done all that is to be done in these respects, it is a matter of practical experience to discover whether ultra-short wave television broadcasting is or is not possible. The writer's feeling is that a serious campaign to induce motor car manufacturers to put suppressor resistances in their ignition systems will be a necessary prelude to any sort of satisfactory service, and the success of this campaign will be the main condition of success in the whole enterprise.

We now return to the consideration of the former of the two problems, and we are at once faced with the necessity for an important series of decisions which, it must be borne in mind, have to be made for the industry as a whole. We require to settle:—

- (a) the number of times the picture is to be scanned per second;
- (b) the shape of the picture and the manner in which scanning is to be carried out;

Television Progress—

(c) the number of picture elements that are necessary for adequate detail.

According to the present Baird system the picture is scanned $12\frac{1}{2}$ times per second in 30 vertical strips; the shape of the picture is seven (vertical) by three (horizontal), and the number of picture points consequently 2,100.

Service in Germany

As a step in the direction of greater detail, the German Post Office has instituted a regular service of experimental ultra-short wave television transmissions from Witzleben in which the picture is horizontally scanned twenty-five times per second in ninety strips, the shape of the picture is five (vertical) by six (horizontal), and the number of picture points nearly 10,000.

It is advisable to examine more closely the steps by which the German authorities arrived at these figures. In the first place, both the shape of the picture and its rate of repetition are in close conformity with the standards chosen for talking films and enable transmissions to be effected by means of a film provided with scanning machinery. The difference between the picture-frequency chosen and that of twenty-four per second has an important bearing upon the problem of synchronising, since it enables motors to be used at both transmitting and receiving ends which are synchronously driven by simple apparatus from the 50 c/s a.c. mains. Had the picture frequency of twenty-four per second, characteristic of talking pictures, been retained for television purposes it would have been necessary to employ an awkward train of gears if synchronisation were to be effected by means of the 50 c/s mains, and it has evidently been found of no detriment to the results obtained to increase the speed of a talking film in the ratio 25:24 when transmitting it for television purposes.

Apart from the talking film question, considerations of flicker indicate the desirability of an increase in the picture frequency from $12\frac{1}{2}$ per second, unless the effect of persistence of vision can be aided by fluorescence, as in the case of the cathode ray tube, or by some similar effect. The prospect of improved operation along these lines cannot be dismissed, as it is possible to obtain better detail with a slow picture frequency, other things being equal, but the importance of talking film transmission would seem to indicate a higher picture frequency such as that chosen in Germany, in spite of the disadvantages which it may entail.

Synchronising and the "Grid System"

It is perhaps worth while to digress for a short space to consider the synchronising problem in greater detail. Synchronism between transmitter and receiver is an essential feature of any television system and the demands for it are in the highest degree exacting, since we must not only ensure that the picture is stationary, but also that it is "correctly framed," i.e.,

not displaced out of its right position. The latter feature necessitates a consideration of the phase relationship between the two systems; the simplest explanation is again to be found in the "book" analogy, if we consider the transmitter to be "looking" at the first word in a line and the receiver to be "pointing," say, at the middle of the same line. If the receiver is half a line ahead all the way it is clear that the left- and right-hand margins of the book page itself will appear adjacent to each other in the middle of the reproduced version at the receiver, and the original page will be divided down the middle, so that the two divisions appear on either side at the receiving end.

Many devices are known according to which the transmitter sends out a synchronising signal to hold the receiver in step with it, and all of them introduce an element of some complexity, since they require that this signal should be separated from those corresponding to the picture modulations. On the other hand, if both the transmitter and receiver are fed from the same alternating current network, synchronism can be automatically established, subject to the existence of a phasing control which will restore any casual displacement of the picture from its correct position. It is uncertain whether all the

supply broadcast all over the country as a 50 c/s modulation of a radio wave and accurately controlled by a high quality tuning fork or astronomical clock. The frequency band required by this signal would be negligible, and it could be used for direct control of electric clocks or television apparatus, in places where no mains supply was available, and also for regulating the frequency of all sections of the "grid system." It is, of course, unnecessary and undesirable to use an ultra-short wavelength for such a "master wave"; the question as to what wavelength should be employed is an entirely open one, and might be decided simply from the standpoint of what was available for use.

Standard of Detail

Returning to the consideration of the researches of the German Post Office, the main decision, namely, that of the degree of detail required, was arrived at experimentally by the production, using purely optical means, of a series of films having different numbers of "picture points." Horizontal scanning was adopted, i.e., in terms of the "book" analogy, referred to last week, exactly corresponding to an ordinary book. The number

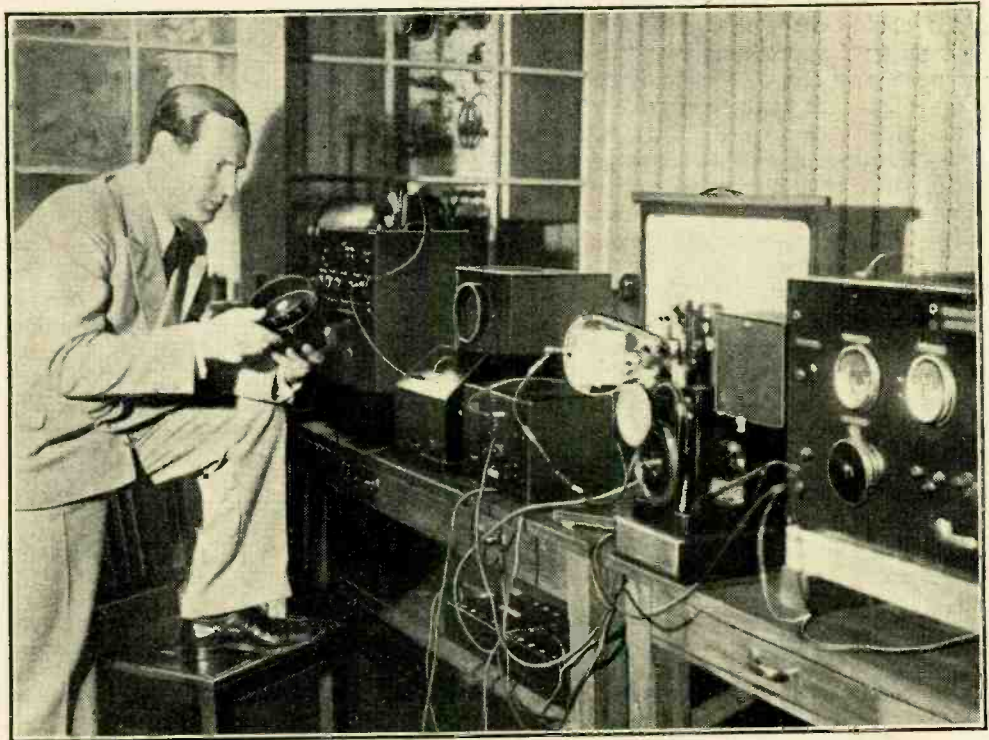

Baron Manfred von Ardenne, an early investigator of television in Germany, and a pioneer of the cathode ray system. In this recent picture he is seen with his latest apparatus employing what is known as the "speed-modulation" system.

alternating current networks in the Central Electricity Board's "grid system" will operate synchronously at all times, but at any rate there is a compelling argument in favour of close regulation owing to the very general use of electric clocks driven synchronously from the mains. Perhaps the slightly greater precision necessary for television purposes might be attained by the provision of a master frequency

of lines was varied in the different films, and the graduation along the lines was made finer in detail as the number of lines was increased, the results being made to conform exactly with what would be obtained in a series of ideal television systems in which scanning was carried out in a manner corresponding to each film.

As would be expected, an improvement in the picture detail was obtained which

Television Progress—

was very marked as the number of lines was increased from 30 upwards, but which became less effective after a certain standard of detail had been achieved. The conclusion was that 90 lines and 10,000 picture points represented a degree of detail which was sufficient for practical purposes, and that a closer analysis only gave a "diminishing return" by way of improvement.

One System or Many ?

From the standpoint of television in this country we have now to consider the question as to whether any standardisation of television transmissions is possible, and, if so, what the nature of the transmissions should be. It is obvious that standardisation is desirable; indeed, it is almost impossible to imagine the alternative situation, where the B.B.C. puts into operation, either in succession or even simultaneously, systems of transmission of a proprietary character designed expressly to work in conjunction with receivers of specific origin. The matter would seem to be one in regard to which the B.B.C. should take great care, since, setting aside the danger of the commercial advantage passing into one set of interests, it is too early to say yet on what lines the future development of television will lie, and it would benefit neither the public nor the industry if a premium were prematurely put upon any one of the many methods of operation that have been advocated.

The alternative to the B.B.C. acting as the only source of transmissions would be for experimental television transmitting licences to be granted by the Postmaster-General to various commercial companies developing television and to amateur experimenters so that the relative merits of a number of schemes could be tried out in practice before the B.B.C. was committed to a service.

There is no doubt that the inauguration of a television broadcasting service on short wavelengths, with increased detail

in whatever measure is considered desirable, would cause an enormous awakening of interest in the whole subject and might, in fact, mark the starting point of industrial developments of the greatest importance. In this situation we look to the Corporation to take the broadest possible view, and, in the light of experience in Germany and elsewhere, and if it sets up,



The Mihaly television receiver shown at the recent Radio Exhibition in Berlin. This system employs a stationary mirror drum, with a rotating reflecting mirror, and an external screen on which the picture is projected. The system was described in the issue of *The Wireless World* of September 15th, 1933.

under its own auspices, a system of transmission it should be one which will allow the fullest possible scope to the endeavours of all sections of the industry. In particular, whatever else is decided, the question of synchronisation should be settled on a basis which is operative for any type of receiver, and in such a manner as to permit the use, wherever possible, of the 50 c/s controlled-frequency mains for synchronous operation.

the medium-wave band. Munich, Vienna, Budapest and Brussels No. 1 never fail to provide entertainment after dusk, and the last-mentioned can be received at any time when it is working. When Brussels goes up to 75 kilowatts the whole of this country should be definitely within its service area.

Brussels No. 2 is also well received, but this is not such a reliable daylight signal. It will also be using 75 kilowatts before long.

Heterodynes have been distinctly troublesome of late, many of the best stations having been affected at times. Luckily, such a thing as a persistent heterodyne night after night on a particular station rarely occurs; it is only now and then that interference is experienced. The choice, anyhow, is so wide nowadays that if one station is suffering there are plenty of others to be had clear of all interference. A programme that is specially attractive can often be received, even if the "parent" station is heterodyned, by tuning in one of the relays.

Specially good stations on the long waves are: Zeesen, Radio Paris, Warsaw and Motala. On the medium-wave band I can recommend Prague, Langenberg, Strasbourg, Heilsberg, Leipzig, Breslau, Katowice, Lyons Doua, Lwow and Beromünster. Fading is beginning to be troublesome below 300 metres for those who have not automatic volume control. D. EXER.

The Radio Industry

THE Chronicle Wireless Annual," issued by the *Manchester Evening Chronicle*, is now in its eleventh year of publication; the latest edition which has just been issued is an extraordinary good shillingsworth, packed with useful information for wireless amateurs. A number of constructional articles (with large-size wiring plans) are included, and modern developments such as Class "B" and Q.P.P. amplification are treated.

Much space is devoted to the present-day aspects of selectivity and quality, and, in addition, sections of the book are devoted to reference data and lists of stations.

Instructional courses in radio technique, especially prepared for the benefit of the would-be service engineer, are now beginning at the Northern Polytechnic, Holloway, London, N.7. Tuition is both practical and theoretical and full information can be obtained from the Organisers.

Atwater Kent radio products are to be distributed in Great Britain by the Portland Radio Co., Ltd., of 62, Bolsover Street, London, W.1.

Standard Telephones and Cables, Ltd., announce the introduction of an Acoustic Noise Meter. The new instrument is self-contained and portable and is operated by a single dry cell. It is calibrated in decibels.

The Technical and Commercial Radio College, of Lloyds Place, Blackheath, London, S.E.3, are conducting radio correspondence courses dealing with the various aspects of the subject.

The needs of students proposing to enter any branch of the industry are catered for; a descriptive brochure describing the activities of the organisation is available on application.

A new Tungram valve, Type LD 210, has just been produced. This valve is for battery operation and is essentially designed to function as a detector, it being claimed that it is entirely non-microphonic.

A new type of screened valve holder, for Ostar-Ganz valves, similar to that illustrated in our issue of September 22nd, is now being manufactured by Lectrolinx, Ltd., of 79a, Rochester Row, London, S.W.1. The British-made version includes all the well-known features of Clix valve holders.

DISTANT RECEPTION NOTES

THOUGH it is reported that Monte Ceneri is shortly to begin operating on its "Lucerne" wavelength of 257.1 metres, the station is now working again near the bottom of the long-wave band, using a wavelength of about 1,150 metres. It is interfering seriously with Kalundborg and making a nuisance of itself generally.

Other nuisances at the moment are Radio Vitus and Radio Agen. Both are off their proper wavelengths.

The new Lisbon 20-kilowatt station, to whose construction I referred some time ago in these notes, is nearly completed, and tests may begin at any time now. The wavelength will be 282 metres until the Lucerne Plan comes into force, after which the station will go up to 476.9 metres, sharing a wavelength with Skoplje, in Yugoslavia, and Trondheim.

Transatlantic reception continues to be remarkably good, and some of the South

American stations are better heard on certain nights than those in the United States. As readers may have some difficulty in obtaining particulars of South American stations, here is a list of some of the most important in the Argentine and in Mexico:—

	Metres.		Metres.
LS9 Buenos Aires	216	XED Renosa,	
LS8 " "	244	Mexico	310.9
LS2 " "	252	XEO Mexico City	319
LR8 " "	261	XEW " "	329
LS5 " "	280	LR6 Buenos Aires	330
LR9 " "	291	LR5 " "	361
LR4 " "	303	XER, Villa Acunha	408

Nearly all of these stations use outputs of 10 kilowatts or more, and the great majority have already been received in this country. With a calibrated set stations are not difficult to identify, since announcements are made in Spanish. Be careful, though, not to be misled by small-hours' programmes from Madrid or Barcelona or Valencia!

From European stations very fine reception is now obtainable at the upper end of

The Wireless World

FOREIGN PROGRAMME SUPPLEMENT

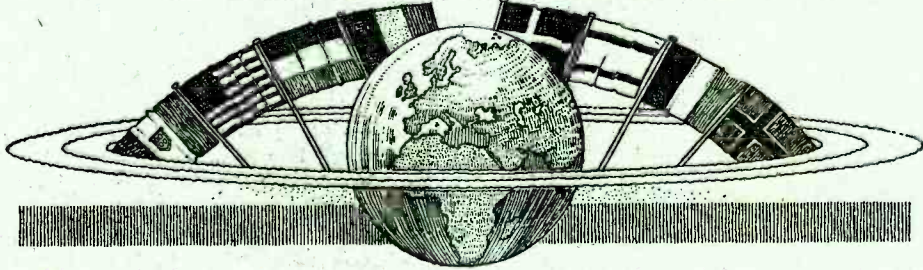

SUNDAY

OCTOBER THE FIFTEENTH

ALGIERS

824 kc/s, 364 metres; 13 kW.—8.2 p.m., Symphony Concert of French Music, conducted by Henry Defosse. In an interval at 7.45, News. 9.30, News. 9.35, Readings (Porto-Riche, La Fontaine and Victor Hugo). 9.55, News.

ATHLONE

725 kc/s, 413 metres; 60 kW. Relayed by Gork, 1,337 kc/s, 224.4 metres.—8.30 p.m., Time Signal. 8.32, The Station Orchestra. 9.0, John McDonagh in Original Songs and Sketches. 10.0, Violin Solos by Alice Feeley. 10.15, Soprano Solos by Mine. Heffernan. 10.30, The Station Orchestra. 11.0, Time, News, Weather and Close Down.

BARCELONA

EAJI, 860 kc/s, 348.8 metres; 8 kW.—11.0 a.m., Chimes and Weather. 1.0 p.m., Gramophone Music. In the interval at 1.30, Theatre Notes. 2.0, Sextet Concert. 3.0, Programme for Hospitals and other Benevolent Institutions, with Gramophone Records. 4.0 to 5.30, Interval. 5.30, Agricultural Talk and Gramophone Music. 6.0, Concert by the Station Orchestra. 6.30, Song Recital by Enrique Alabert. 7.0, Music by the Station Orchestra. 7.30, Song Recital by Pepita Paulet. 8.0, Dance Music relayed from Hollywood Bar. 9.0, A Musical Comedy Selection on Gramophone Records. 10.45, Chess Lesson. 11.0 (approx.), Close Down.

BARI

1,112 kc/s, 269.8 metres; 20 kW.—9.0 to 9.45 a.m., See Rome. 9.45, Bible Reading. 10.0 to 11.0, See Turin. 11.30, See Rome. 11.45 to 1.0 p.m., See Turin. In the interval from 12.30 to 12.45, See Rome. 1.0 to 5.30, See Rome. 6.20, Talks and Gramophone Music in Honour of King Zog I of the Albanians. 7.0 (approx.) till Close Down, See Rome.

BASLE.—See Schweizerischer Landessender.

BELGRADE

697 kc/s, 430.4 metres; 2.8 kW.—6.40 p.m., Vocal and Instrumental Concert. 9.0, Time and News. 9.15 (approx.), Cigány Music from the Dva Jelena Restaurant.

BERLIN

DEUTSCHLANDSENDER (Reichssender), 183.5 kc/s, 1,635 metres; 60 kW.—5.30 a.m., To-day's Motto. 5.35 (approx.), Concert from Munich. 7.0, Agricultural Programme. 7.55, Chimes from the Potsdam Garrison Church, followed by Divine Service from the Village Church of Wittenau. 8.55 to 9.20, Interval. 9.20 (approx.), See Munich. 10.45, Weather Report. 11.0 to 1.0 p.m., Gramophone Concert. 1.0, Programme for Children. 1.30, Talk for Young People: Jahn, the Pioneer of the German Gymnastic Movement. 2.0, Ernst Leibl reads from his own Works. 2.20, Gramophone Concert of Classical Music. 3.0, Humorous Talk. 3.15, Talk on Max Sievert, on his Sixty-Fifth Birthday. 3.30, Concert from Munich. 4.40, Rural Programme—Anecdotes and Stories. 5.10, Dialogue between Professor Senatra and Signora Ali: German and Italian Opera. 6.0, See Munich. 7.0, See Leipzig. 7.30, See Stuttgart. 8.0, See Munich. 8.30, See Langenberg. 9.0, News. 9.45, Weather. 10.0, See Munich. 11.0 (approx.), Close Down.

BERLIN

FUNKSTUNDE, 715 kc/s, 419.5 metres; 1.5 kW.—9.20 a.m. to 12 Noon, See Munich. 12 Noon, Das Gedicht einer Leidenschaft (Herbert Böhme), recited by the Author to Music by Hanns Naumann. 12.30 to 1.0 p.m., Concert of Light Music on Gramophone Records. 1.30, Play for Children. 2.15, Civilisation of Berlin. 2.30, Report of the Light Athletic Tournament from the

Karlshorst Race Course. 2.45, Orchestral Concert of Light Music. In the interval at 4.0, Radio Report from a Water Mill (on Gramophone Records). 5.0, Some Odd Characters—A Radio Sequence (Herbert Günther). 5.30, Italian Artists—Gramophone Concert. 6.0, See Munich. 7.5, Der Amtmann von Mainburg—Operetta in Three Acts (Josef Snaga). 9.0, News. 9.15 (approx.), Dance Music from the Eden Pavilion. In the interval from 10.0 to 10.10, Topical Talk. 12 Midnight, Close Down.

BERNE.—See Schweizerischer Landessender.

BEROMUNSTER.—See Schweizerischer Landessender.

BODEN.—See Stockholm.

BODO.—See Oslo.

BORDEAUX-LAFAYETTE

986 kc/s, 304 metres; 13 kW.—6.15 p.m., Radio Journal. 7.45, Sports Talk. 8.0, Talk for Ex-Service Men. 8.15, Lottery Results. 8.20, Concert of Gramophone Music.

BRATISLAVA

1,076 kc/s, 279 metres; 14 kW.—4.55 p.m., Song and Violin Recital of Svoboda Music. 5.55, Talk for Housewives. 6.0, See Prague. 6.5, See Brno. 6.40, Concert of Popular Music by the Station Orchestra, conducted by Dyk. 7.30, See Moravská-Ostrava. 8.30, Bandonion Concert. 9.0, See Prague. 11.0 (approx.), Close Down.

BREMEN.—See Hamburg.

BRESLAU

923 kc/s, 325 metres; 60 kW. Relayed by Gleiwitz, 1,184 kc/s, 253 metres.—9.20 a.m., See Munich. 10.45, Chamber Music on Gramophone Records. 11.0, Concert by the Station Orchestra, conducted by Topitz. 1.0 p.m., Agricultural Talk. 1.20, Talk: Wireless and Weather. 1.35, Reading (Schmidt-bonn). 2.0, Choral Concert from Waldenburg. 2.30, Programme for Children. 3.0, Concert by the Silesian Philharmonic Orchestra, conducted by Ernst Hoffmann. In the interval from 4.0 to 4.25, Radio Report from the Gölitz Garden City. 5.35, Talk: A Railway Station celebrates its Birthday. 6.0, See Munich. 7.0, See Leipzig. 7.30, See Stuttgart. 8.0, See Munich. 8.30, See Langenberg. 9.0, Time and News. 9.30, Dance Music from Berlin (Funkstunde). 12 Midnight, Close Down.

BRNO

878 kc/s, 342 metres; 35 kW.—11.15 a.m., Concert by the Brno Brass Band, conducted by Krenovsky. 12.30 p.m., Agricultural Programme. 12.45, Programme to be announced. 1.0, Interval. 3.0, Concert by the Station Orchestra, conducted by Janota; Soloist: Vlasta Kubikova-Janotova (Soprano). 4.30, Reading. 4.45, Gramophone Music. 5.0, German Transmission: La folia Violin and Piano Recital: La folia (Corelli); Largo (Vivaldi); Lullaby (Steiner); Serenade (Steiner); Spanish Dance (Falas). 6.0, See Prague. 6.5, Moravian Folklore Programme, relayed from Kosice, 1,022 kc/s (293 metres). 6.40, See Bratislava. 7.30, See Moravská-Ostrava. 8.30, See Prague. 10.0 (approx.), Close Down.

BRUSSELS (No. 1)

I.N.R., 590 kc/s, 509 metres; 15 kW.—10.0 a.m., Concert by the Small Station Orchestra, conducted by Leemans. 11.0, Mendels-

ohn Gramophone Concert. 12 Noon, Concert by the Radio Orchestra, conducted by Walpot. Soloist: Rosasco (Mouth Organ and Accordion). 1.0 p.m., Le Journal Parlé. 1.10, Programme by Mickey's Club Jazz Attraction. 1.30, La Muse de Bibochard—Sketch (Lauville). 1.40, Mickey's Club Jazz Attraction (contd.). 5.0, Dance Music relayed from the St. Sauveur Palais de Danse. In the interval at 5.30, Football Results. 6.15, Gramophone Music. 6.45, Sonata Recital by Mme. Husson-Michaux (Pianoforte) and Frezin (Cello): Cello and Pianoforte Sonata (Boëllmann); Dance for Cello and Pianoforte (Sevenants). 7.15, Religious Address. 7.30, Music Talk by Gilson. 8.0, Concert by the Radio Orchestra, conducted by Walpot. Soloist: Mme. Suzanne de Gavre (Songs). 8.40, Our Future—Farce in One Act (Feydeau). 9.0, Concert by the Station Symphony Orchestra. 10.0, Le Journal Parlé.

BRUSSELS (No. 2)

N.I.R., 887 kc/s, 338.2 metres; 15 kW.—Programme in Flemish. 10.0 a.m., Gramophone Concert. 11.0, Concert by the Small Station Orchestra, conducted by Leemans. 12 Noon, Concert by Mickey's Club Jazz Attraction, conducted by Ludo Langlois. 1.0 p.m., Journal Parlé. 1.10, Concert by the Radio Orchestra, conducted by Walpot. Soloist: Rosasco (Accordion). 5.0, Concert by the Station Symphony Orchestra, conducted by Meulemans. 5.30, Sports Results. 6.0, Modern English Music on Gramophone Records: Tintagel (Bax); Mediterranean (Bax); Dance (Scott); Miniature Suite (Coates). 6.30, Concert by the Small Station Orchestra, conducted by Leemans. 7.15, Religious Address. 7.30, See Brussels, No. 1. 8.0, Concert of Rhapsodies by the Station Symphony Orchestra, conducted by Meulemans: Rhapsody, Piet Hein (Anrooy); Clarinet Solo: Rhapsody (Debussy); Rhapsodie dahoméenne (De Boeck); Rhapsody for Clarinet and Orchestra (Meulemans); Norwegian Rhapsody (Lalo). 8.45, Humorous Programme. 9.0, Concert by the Radio Orchestra. 10.0, Journal Parlé.

BUCHAREST

761 kc/s, 394 metres; 12 kW.—4.0 p.m., Light Music and Romanian Music by the Jean Marco Orchestra. In the interval at 5.0, Radio Journal. 6.0, Educational Programme. 6.20, Dance Music. 7.0, Concert by the Station Orchestra: Selection from Iphigenia in Aulis (Gluck); Liebeslieder (Brahms); Ballet Music from Manon (Massenet). 7.40, Song Recital by Mlle. Zgurdadescu, with Orchestral accompaniment: Arias from Don Giovanni (Mozart), and The Magic Flute (Mozart); Polonaise from Mignon (Thomas). 8.15, Concert (contd.): Roses of Florida (Fall); Gavotte (Popper); Military March (Saint-Saëns). 8.45, Radio Journal.

BUDAPEST

545 kc/s, 550.5 metres; 18.5 kW. Also relayed on 840 metres from 7.0 p.m., till Close Down.—8.15 a.m., News. 9.0, Divine Service relayed from the University Church. 10.15, Evangelical Service, followed by Concert by the Opera House Orchestra, conducted by Ernst Dohnanyi. In the interval, Radio Chronicle. 1.0 p.m., Gramophone Concert. 2.0, Agricultural Talk. 2.45, Radio Report from the Vintage in Tokay. 3.30, Talk. 4.0, Concert by the Eugen Pertis Cigány Band. 5.15, Humorous Programme. 5.45,

Programme to be announced. 6.45, Sports Notes. 7.0, Concert of Operetta Music by the Budapest Concert Orchestra, conducted by Polgar. 8.30, News. 8.45, Pianoforte Recital. 9.25, Concert by the Mándits Dance Band and the Béla Bodrics Cigány Band, relayed from the Café Patria: Soloist: Gyula Szántho (Songs).

CASSEL.—See Frankfurt.

COPENHAGEN

1,067 kc/s, 281 metres; 0.75 kW. Relayed by Kalundborg, 260 kc/s, 1,153.8 metres.—7.0 a.m., Gymnastics for Women. 7.15, Gymnastics. 8.0 to 8.30, Talk on Gardening. 9.0, Divine Service Relay. 10.30, Weather and News. 11.0, Town Hall Chimes. 11.2, Concert of Light Music by the Louis Preil Instrumental Ensemble. 12 Noon, Talk in English: The Grand Tour of Scotland. 12.20 p.m., Talk in German: On a Bicycle through Germany in 1933. 12.40, Talk in French. 1.0, Gramophone Concert. 1.30, Accordion Recital by Alex and Richard. 1.55, Programme for Children. 2.25, Wagner Concert from the State Broadcasting Building: The Station Symphony Orchestra, conducted by Nicolai Malko: Soloist: Lauritz Melchior (Tenor). 4.0 (also relayed on Skamlebaek, 31.51 metres), Divine Service Relay. 5.20, Talk: The American Worker. 5.50, Weather and News. 6.15, Time Signal. 6.30, Talk. 7.0, Town Hall Chimes. 7.2, Pianoforte Trio No. 3 in C (Haydn). 7.25, Folk Music and Folk Tales—Musical and Literary Programme: a Male Voice Choir (conducted by Rosenberg), and Missa Hellmers (Readings). 8.30, The Hansen Family—Humorous Episode (Locher). 8.45, News. 8.55, Operetta Music by the Radio Orchestra, conducted by Reesen. 9.50, Dance Music by the Otto Lington Band, relayed from the Ritz Restaurant. In the interval at 11.0, Town Hall Chimes. 11.30 (approx.), Close Down.

GORK.—See Athlone.

DANZIG.—See Heilsberg.

DRESDEN.—See Leipzig.

FECAMP

1,328 kc/s, 225.9 metres; 10 kW.—11.0 a.m. to 12.30 p.m., Programme in English by the I.B.C. 11.0 a.m., Happy Hour: Signature Tune; Overture, Il Seraglio (Mozart); Morning, from the Peer Gynt Suite (Grieg); Choir: Deep River (Traditional); Softly awakes my Heart, from Samson and Delilah (Saint-Saëns); Selection from Il Trovatore (Verdi); Choir: Swing low, sweet Chariot (Traditional); Hungarian Rhapsody No. 2 (Liszt). Part II, Organ Recital: Ca c'est Madrid (O'Henry); The White Dove (Lehar); The Organ Grinder; In a Chinese Temple Garden (Ketelbey); Weymouth Chimes (Lindahl); Il Bacio (Arditi); Signature Tune. 12.0 Noon, Variety Concert: Singing through Georgia; I'll never have to dream again; Then I'll be happy; Romance; Red Pepper Rag; How deep is the Ocean?; Down in the Valley; Fit as a fiddle; I'm knee deep in Daisies; Somewhere a voice is calling; I'm in love with you; Deep in your memories; A pretty girl is just like a pretty dream. 12.30 p.m., Programme in French. 2.30 to 7.30, Programme in English by the I.B.C. 2.30, Orchestral Concert: March, Pride of the Wolferrines (Souza); Dance of the Nymphs (Birch); Selection from The Chocolate Soldier (O. Strauss); Fairy Tale (Heykens); Quartet: Homing (del Riego); Velela Medley (Varney); The Clatter of the Clogs (Flynn); La Czarine (Ganne). 3.0, Concert. Part I: America Calling (Pola); Back in the old Sunday School (Lord); Cowboy Joe; Minstrel Show of 1929. Part I: Here comes the Show Boat (Rose); I dream of you last night (Kálmán); Minstrel Show of 1931. Part I: Will you think of me? (Kálmán); Part II, Xylophone Solo: Squirrel Dance (Elliott-Smith); Yodelling Rag Man (Torrani); Pianoforte

OCT. 15th **SUNDAY** continued

Solo: Moon Song (Johnstone); Xylophone Solo: Dance of the Paper Doll (Tucker); Pianoforte Solo: Dancing Butterfly (Petkere); Song: You are too beautiful (Hart); Harp Solo: Aloha (Traditional); Negro Spiritual Medley. 4.0. Judge Rutherford's Address. 4.15. The Nursery Corner. 5.0. Military Band Concert: Marche Militaire (Schubert); Præludium (Järnefeldt); A Life on the Ocean (Binding); Parade of the Tin Soldiers (Jessel); Valse des Alouettes (Drigo); Selection, The Pirates of Penzance (Sullivan); Amorettenanz (Gungl); The Standard of St. George (Alford). 5.30. I.B.C. Members' Request Hour: Selection, Music in the Air; Song: You are my heart's delight (Lehar); Ocarina Solo: Under the Double Eagle (Tapiero); I do like to be beside the Seaside (Glover); Selection from Carmen (Bizet); The Blue Bird (Bordin); Song: I love the Moon (Rubens); Makin' Wicky Wacky down in Waikiki (Hoffmann). 6.0. Light Orchestral Concert: Ginger Snaps (Bourdon); Pianoforte Solo: Magic Notes (Steining); Cœur brisé (Gillet); In the Night (Tate); Selection from Wonder Bar (Katscher); Marching through Georgia (Wark); When the lilac blooms again (Rotter); Selection of Waltzes (Ancliffe). 6.30. Concert of Gramophone Records: Gracie Fields: How deep is the Ocean? (Berlin); Layton and Johnstone; It's Sunday down in Caroline (Symes); Paul Robeson: Wid de moon, moon, moon (Cook); Jack Payne: Oh Johanna (Lawrence); The Revelers: When Yuba plays the Rumba on the Tuba (Hupfeld); Stanley Holloway: Sam's Medals (Hogan); Debroy Somers: Selection from Give me a Ring; Jack Hulbert: The flies crawled up the window. 7.0. Orchestral Concert: Rakoczy March (Berlioz); Ballet from the Petite Suite (Debussy); On the Edge of the Lake (Coates); Dance of the Sylphs (Berlioz); Polonaise in A major (Chopin); Witches' Ride (Puccini); Morning from the Peer Gynt Suite (Grieg); Concert Waltz in D (Glazounov). 7.30 till 9.0. Programme in French. 9.0 till Close Down. Programme in English by the I.B.C. 9.0. Ballito Concert of Dance Music: Signature Tune, Happy Feet; Isn't it Heavenly? (Meyer); Tick Tock (Vienna); From me to you (King); Nobody's Sweetheart (Kahn); He was only a poor musician (Schwarz); Avalon (Rose); Let's all be happy together (Thomas); Goodnight but not Goodbye (Roberts); Signature Tune, Happy Feet. 9.30. Talk Time. Signature Tune, Sittin' in the Dark; Selection from Il est Charmant (Moretti); Mrs. Bartholomew (Ellis); There'll still be love (Marvel); Live, laugh and love (Heymann); A nous la Liberté (Auric); In the Moonlight (Kelmars); I've found the right Girl (Lupino); Selection from The Kid from Spain (Kalmars); Signature Tune. 10.0. Accordion Band: Whistling Waltz (Reeves); C'est un petit nid (Ehlinger); Waltz, Morella (Charlier); Song: Down in the Valley (Harrington); La Javanette (Bozi); Annette (Phillips); Song: Having a Good Time (Pain); J'aime la Musique (Parsons). 10.30. Concert of Dance Music: Lazyhops (Mercer); Wedding of the Dragonflies (Myers); Happy as the day is long (Arlien); Sing another line (Robinson); Trouble in Paradise (Schwarz); 'Twixt the devil and the deep; Blue Cloud (Hargreaves); Five-Fifteen (Hall); My Moonlight Madonna. 11.0. Variety Concert: Signature Tune, Happy days are here again; It's Sunday down in Caroline (Symes); Lazyhops (Mercer); Reflections in the Water (Loeh); I always keep my girl out late (Abraham); My Gypsy Rhapsody (Lawrence); A Girl like Nina (Hammerstein); Let's Call it a Day (Brown); Signature Tune, Happy Days are here again. 11.30. Concert by the I.B.C. (Ireland), Ltd., on behalf of the Irish Hospitals Sweepstakes Authorities: Signature Tune, Come back to Erin; Overture Medley (arr Peters); In Pierrette's Garden (Clifton-Brooks); A good old Irish Stew; Columbine (Garland); Song: Nirvana (Adams); Liebesfraud (Kreiser); Pizzicato from Sylvia (Delibes); Selection from Die Fledermaus (Joh. Strauss); Signature Tune, Come back to Erin. 12.5 a.m. (Monday), News Bulletin in English. 12.10 (approx.), Club Concert for Sheerness Listeners: Signature Tune, The Chum Song; My Gypsy Rhapsody (Lawrence); Under a Blanket of Blue (Symes); A Woman should stick to her Man (Iida); Learn to croon (Coslow); At the Old Pig and Whistle (Butler); I can't remember; There's a Cabin in the Pines; I wish I had Wings; Someone stole Gabriel's Horn; Have you had a good day to-day?; My first Love to last; Hold me; Adorable; Signature Tune. 1.0. Dance Music: Signature Tune, Bells of Normandy; Somebody stole my Gal; I cover the waterfront; That's what life is made of; I raised my Hat; The Shadow Waltz; This lovely Rose; My tiny Tear; Hiawatha's Lullaby; Sweep; My! oh, My; You don't understand; Something came and got me in the Spring; Peter, Peter; Little Miss Muffet; Pop Gun; Out in the Open; Signature Tune. 2.0. I.B.C. Goodnight Melody and Close Down.

FLensburg.—See Hamburg.
FLORENCE.—See Turin.

FRANKFURT

1,157 kc/s, 259.3 metres; 17 kW. Relayed by Cassel and Trier, 1,157 kc/s, 259.3 metres.—9.20 a.m., See Munich. 11.0 a.m., Stahlihelm Demonstration. 12 Noon, See

Stuttgart. 12.15 p.m., Gramophone Concert of Light Music. 12.45, Talks arranged by the Wiesbaden Board of Agriculture. 12.55, Rural Programme—Talk. 1.30. See Langenberg. 2.30. Commentary from the Bird Sanctuary in Heligoland. 3.0. See Langenberg. 5.0. Talk: The News Service. 5.30, Ent'acte. 6.0. See Munich. 7.0. See Leipzig. 7.30. See Stuttgart. 8.0. See Munich. 8.30. See Langenberg. 9.0. Time and News. 9.20. See Stuttgart. 9.30 (approx.). Local News. 9.45, Light Music. 10.0. Concert of Light Music by the Station Orchestra, conducted by Hans Rosbaud. 11.0. See Stuttgart. 1.0 a.m. (Monday), Close Down.

FREDRIKSSTAD.—See Oslo.
FREIBURG.—See Stuttgart.

GENEVA.—See Radio-Suisse Romande.

GENOA.—See Turin.

GLEIWITZ.—See Breslau.

GOTEBORG.—See Stockholm.

GRAZ.—See Vienna.

HAMAR.—See Oslo.

HAMBURG

806 kc/s, 372 metres; 1.5 kW. Relayed by Bremen, 1,112 kc/s, 269.8 metres; Flensburg, 1,319 kc/s, 227.4 metres; Hanover, 530 kc/s, 566 metres; and Kiel, 1,292 kc/s, 232.2 metres.—9.55 a.m., Divine Service from the Cathedral in Lübeck, for the Opening of the National Artisans' Week. 11.15, Variety Programme from the Ufa Palast. 11.55, Time and Weather. 12 (Noon), Concert by the Small Station Orchestra, conducted by Gerhard Maus. 1.0 p.m., Programme for Children. 2.0, Guitar and Mandoline Recital. 2.30, Talk: Sparow Hawks in Venezuela. 4.0, Wind Instrument Concert. 4.30, The Journey to Brunswick—Humorous Radio Play in Seven Scenes from the Book of Adolf Baron Knigge and Hugo Bartels. 5.30 (from Hanover), Programme by the Brunswick Provincial Theatre. 6.35, Sports Notes and Weather. 7.0. See Braslau. 9.0. News. 9.30, Review of Events in North Germany. 9.45, Programme from Berlin (Funkstunde).

HANOVER.—See Hamburg.

HEILSBERG

1,085 kc/s, 276.5 metres; 60 kW. Relayed by Danzig, 662 kc/s, 453.2 metres.—11.0 a.m., Concert by the Königsberg Opera House Orchestra, conducted by Wolfgang Bücker. Soloist: Ilonka von Ferenczy (Soprano). 1.0 p.m., Talk on Chess. 1.30, Stories for Young People. 2.0, Autumn—Play for Children (Obrig). 2.40 (from Danzig), Police Band Concert. In the interval at 3.50, Sports Notes. 4.40, Talk: The Glamour of the Stage. 5.5, Folk Tales and Anecdotes. 5.30, Music by East Prussian Composers. 6.15, The Hunter and his Horn—a Talk with Musical Illustrations. 6.45, Sports Notes. 7.0, A Musical Trip round the World—Concert by the Königsberg Opera House Orchestra, conducted by Erich Borsche. 9.0. News. 9.15 (approx.), Dance Music from Berlin (Funkstunde). 11.0 (approx.), Close Down.

HILVERSUM

1,013 kc/s, 296.1 metres; 7 kW. up to 5.40 p.m., and 20 kW. from 5.40 p.m.—8.10 to 9.40 a.m., Programme of the Workers' Radio Society (V.A.R.A.). 8.10, Pigeon Flying and Football Report. 8.12, Horticultural Talk. 8.40, Organ Recital. 9.0, Gramophone Music. 9.20, Organ and Cello Recital. 9.40 to 10.10, Interval. 10.10 to 11.40, Programme of the Liberal Protestant Radio Society (V.P.R.O.). Divine Service Relay. 11.40 to 4.40 p.m., Programme of the Algemeene Vereeniging Radio Omroep (A.V.R.O.). 11.40, Talk on Films. 12.10 p.m., Concert of Light Music by Hans Schindler and his Orchestra. In the interval: Music by a Male Voice Choir. 1.40, Weekly Book Talk. 2.10, Concert relayed from the Concertgebouw, Amsterdam. The Concertgebouw Orchestra, conducted by Pierre Monteux. Soloist: Samuel Duskin (Violin). 3.40, Gramophone Music. 4.25, Sports Notes and Gramophone Music. 4.40 to 7.40, Programme of the V.A.R.A. 4.40, Programme for Children. 5.40, Orchestral Concert, conducted by De Groot, 6.30, The Adventures of Wakker and Tropenduit. 6.50, Concert (contd.). 7.40 till Close Down. Programme of the A.V.R.O. 7.40, Time and News. 7.55, Concert by the Wireless Orchestra, conducted by Albert van Raalte. Soloists: Helene Cals (Soprano) and Joseph Sziget (Violin). Beethoven Programme: Coriolanus Overture; Two Songs: (a) Freundvoll und leidvoll, (b) Die Trommel gerührt; Violin Concerto in D. 8.50, Recitations. 9.10, Concert (contd.). Strauss Programme: Overture, The Gipsy Baron; Czardas from Die Fledermaus; Wiener Blut; Polka, Tritsch-Tratsch; Frühlingsstimmen; Persian March. 9.55, Gramophone Music. 10.10, Concert of Light Music by Hans Schindler and his Orchestra. 11.10, Gramophone Music. 11.40 (approx.), Close Down.

HORBY.—See Stockholm.

HUIZEN

160 kc/s, 1,875 metres; 7 kW (until 3.40 p.m.). Transmitted from Kootwijk on 50 kW. from 3.40 p.m.—8.10 to 9.10 a.m., Programme of the Christian Radio Society (N.C.R.V.). Divine Service. 9.10 to 4.40, Programme of the Catholic Radio Society (K.R.O.). 9.10, Gramophone Music. 10.10, High Mass from Breda. 11.40, Talk. 11.55, Concert by the Vienna Station Octet: Hail to the Spirit of Liberty (Sonsa); Red Roses (Lehar); Overture, Gri-Gri (Lincke); Elf Dance (Heykens); I hab a mal a Käuscherl g'habt (Kapeller); Selection from Tiefand (d'Alberty); That naughty Waltz (Levy). 12.40 p.m., Talk. 1.0, Concert (contd.): Selection from The Geisha (Jones); An den Frühling (Grieg); Japanese Lantern Dance (Yoshitomo); Waltz, Wiener Blut (Strauss); Im Chambre separée (Henberger); Finale. 1.40, Religious Address. 2.10, Orchestral Concert, conducted by Gerritsen. 2.40, Concert by the Volksadet Mixed Choir and the Breda Orchestra. 3.40, Orchestral Concert (contd.). 4.10, Programme for Hospitals. 4.40 to 7.25, Programme of the N.C.R.V. 4.40, Sacred Music on Gramophone Records. 5.10, Divine Service from Wemeldingen, followed by Sacred Music. 7.25 till Close Down. Programme of the K.R.O. 7.25, Football Report. 7.30, Talk on the Work of the Missions to the Negroes, with Interludes by the Oosterhout Orchestra. 8.25, News. 8.30, Quartet No. 8 (Haydn) by The Hague Quartet. 8.50, Gramophone Music. 9.5, Quartet in D Minor (Schubert) by The Hague Quartet. 9.35, Gramophone Music. 9.50, News. 9.55, Concert by the Station Orchestra conducted by Gerritsen: Overture, Undine (Lortzing); Ballet Music from Undine (Lortzing); Polonaise National Dance No. 1 (Scharwenka). 10.20, Choral Epilogue. 10.40 (approx.), Close Down.

INNSBRUCK.—See Vienna.

JUAN LES PINS

1,205 kc/s, 249 metres; 0.8 kW.—8.0 p.m., Amusement Guide and Sports Notes. 8.15, Radio Concert. 9.0, News. 9.15, Radio Concert. 10.0, Request Half-Hour. 10.30 till Close Down, Programme in English by the I.B.C. 10.30, Orchestral Concert. Selection from "Mother of Pearl" (O. Strauss): Ständchen (Schubert); Song: Roses at Dawning (Kahn); Waltz (Lincke); Chant sans paroles (Tchaikovsky); Song: Juanita (Norton); Roses from the South (Strauss). 11.0, Gramophone Music. Military Band: Le rêve passe (Krier); Sketch: Scenes of Domestic Bliss—Breakfast Time; Midnight; Orchestra: The Musical Clock of Madame Pompadour (Noack); Organ Solo: Drifting down the Shalimar (Monaco); Song: The Leader of the Town Brass Band (Longstaffe); Pianoforte and Organ Duet; Mariold (Mayerl); Orchestra: Melodious Memories (arr. Finck). 11.30, Instrumental Music. Orchestra: Jollification (Reeves); Pianoforte Solo: Selection from Bow Bells (Sullivan); Violin Solo: Le Balcon (St. Denis); Xylophone Solo: The Skaters' Waltz (Waldteufel); Pianoforte Solo, with Celeste Accompaniment: Serenade (Heykens); Hawaiian Trio: When Work is through (Sherman); Accordion Band: Coal Black Mammy (Cliff); Bandonian Solo: Blaze Away (Holzmann). 12 Midnight, Dance Music. Standing on the Corner; I'm one of the Lads of Valencia; Look what you've done; Maybe I love you too much; Street of Dreams; Hold me; Love will find a Way; Piccaninnies' Heaven; In the Valley of the Moon; Moon Song; Don't be late in the Morning; The Old Spinning Wheel; It's within your power; The Lady I love; Butterflies in the Rain; My Heart's to let. 1.0 a.m. (Monday), I.B.C. Good-night Melody and Close Down.

KALUNDBORG.—See Copenhagen.
KIEL.—See Hamburg.

KLAGENFURT.—See Vienna.

KOSICE.—See Prague.

LAHTI

167 kc/s, 1,796 metres; 40 kW. Relayed by Helsinki, 815 kc/s, 368.1 metres.—4.59 p.m., Time and Weather. 5.10, Talk. 5.35, The Queen of Spades—Opera (Tchaikovsky), relayed from the Opera House.

LANGENBERG

635 kc/s, 473 metres; 60 kW.—9.50 a.m., A Radio Sequence from the Works of National Socialist Writers. 10.30, Anecdotes about Musical Masterpieces—Talk with Gramophone Illustrations. 11.0, See Frankfurt. 12 Noon, See Stuttgart. 12.15 p.m., Musical Programme. 1.30, Programme for Children. 2.30, Talk on Chess. 2.45, Reading (Wilhelm Frenemann). 3.0, Concert by the Augmented Orchestra, conducted by Kühn. Soloists: Pirro Surana (Baritone) and Paul Mauel and Hans Haass (Pianoforte). 5.0, Reading (Otto Gmelin). 5.20, Gramophone Music. 5.40, Talk: Industry in the Village of Niederkall in the Eifel. 6.0. See Munich. 7.0. See Leipzig. 7.30. See Stuttgart. 8.0. See Munich. 8.30, Richard Strauss Concert.

9.0, Time and News. 9.20, See Stuttgart. 9.30 (approx.), News. 9.45 to 11.0, See Frankfurt. 11.0, See Stuttgart. 1.0 a.m. (Monday), Close Down.

LAUSANNE.—See Radio-Suisse Romande.

LEIPZIG

769.9 kc/s, 363.6 metres; 120 kW. Relayed by Dresden, 941 kc/s, 319 metres.—10.30 a.m., Dialogue in Commemoration of Felix Dahn. 11.0, Concert from Heilsberg. 1.0 p.m., Weather and Time. 1.5, The Programme of the Week. 1.25, Agricultural Notes. 1.35, Hallo, here is the Wireless Zoo. 2.10, Trio in B for Pianoforte, Violin and Cello, Op. 97 (Beethoven). 2.40, Talk in Honour of Gustav Frenosen's Seventieth Birthday. 3.0, Variety Programme. 3.30, Concert by the Leipzig Symphony Orchestra, conducted by Theodor Blumer. Soloists: Johanna Barklin (Soprano), Max Krämer (Violin) and Alfred Putzak (Cello). 5.0, Reading from the Works of Josef Görres. 5.20, Farewell to Water Sports—Radio Report of the last Rowing Races on the Elbe. 5.40, Talk: Pioneers of the Nazi Race Policy. 6.0, Choral and Organ Recital of Sacred Music from St. George's Church, Rothera. 6.30, Stages which mirrored the World—Tales of the Old German Court Theatres. 7.0, Mozart-Reger Music by the Symphony Orchestra, conducted by Fritz Weisbach: Overture, Idomeo (Mozart); Variations on a Mozart Theme (Reger). 7.30, See Stuttgart. 8.0, See Munich. 8.30. See Langenberg. 9.0, News. 9.15 (approx.), Programme to be announced. 10.0, Dance Music Relay. 11.0 (approx.), Close Down.

LINZ.—See Vienna.

LUXEMBOURG

352 kc/s, 1,191 metres; 200 kW.—12.0 Noon, Concert by the Radio Orchestra, conducted by Henri Peusis: Overture, Anacron (Cherubini); Selection from Le Postillon de Longjumeau (Adam); Dolce Melodia (Caludi); Ballet Suite from Sylvia (Delibes); The Clock is playing (Blaauw); Mareh, El Capitan (Sonsa). 1.0 p.m., Gramophone Music. 7.0 till Close Down, English Evening. 7.0, Gramophone Concert: Brigg Fair (Delius); In a Summer Garden (Delius); Enigma Variations, Op. 36 (Elgar). 8.0, Concert by the Radio Orchestra; Soloist: Carl Delseit (Pianoforte); Pianoforte Concerto in E Flat—The Emperor—(Beethoven); Les Préludes (Liszt). 8.50, News in French. 9.0, Popular Music by the Radio Orchestra: Selection from The Maid of Artois (Balfe); Selection from Maritana (Wallace); Waltz, The Wedding of the Winds (Hall); Dreaming (Haydn-Wood); Dance of the Merry Mascots (Ketelbey). 9.45, News in German. 9.55, English Songs on Gramophone Records. 10.15, Dance Music on Gramophone Records.

MADRID

ARANJUEZ (EAO), 10,000 kc/s, 30 metres; 20 kW.—10.30 p.m., Concert of Popular Music. In the interval at 10.45, Humorous Talk. 11.35, Talk. 11.45, Light Music. 12 Midnight-12.30 a.m. (Monday), Programme in English by the I.B.C.: Concert by the International Broadcasting Company (Ireland): Signature Tune, Come back to Erin; The Regiment of Peace; Yes, Mr. Brown; The Blue Danube; I love you; Hawaiian Sunset; I may be wrong, but I think you are wonderful; Marta; That's my Home; Signature Tune: Come back to Erin. 12.30, I.B.C. Goodnight Melody.

MADRID

EAJ7, 707 kc/s, 424.3 metres; 2 kW.—8.0 to 9.0 a.m., Topical Review. 11.30, Municipal Band Concert from the Retiro. 2.0 p.m., Chimes, Time, Theatre Notes, and Popular Concert. 4.0, Interval. 7.0, Chimes, Radio Journal, and Dance Music. 8.30, Interval. 9.30, Chimes, Time, and Variety Programme with Woino Wischnewsky (Tenor). 12 Midnight, Chimes. 1.0 to 2.0 a.m. (Monday), Programme in English by the I.B.C.: Dance Music. Lovey; I've told every little star; It's Sunday down in Caroline; Ding, Dong, Ding; We belong together; 18th December Stomp; I've found the right Girl; Climbing up the golden Stairs; Down in the Valley; Hold me; Headin' for a Wedding; Let's call it a Day; Tick Tock; Isn't it Heavenly?; Morella Waltz; Let him live. 2.0, I.B.C., Good-night Melody and Close Down.

MALMO.—See Stockholm.

MILAN.—See Turin.

MORAVSKA-OSTRAVA

1,137 kc/s, 263.8 metres; 11 kW.—9.30 a.m., Reading of Moravian Ballads, with introductory Talk. 10.0, See Prague. 11.15, See Brno. 12.30 to 2.0 p.m., See Prague. 3.0, See Brno. 4.30, See Prague. 6.5, See Brno. 6.40, See Bratislava. 7.30, Hunting—Variety Programme. 8.30, Programme of Dance Music. 9.0, See Prague. 10.0 (approx.), Close Down.

MOSCOW

TRADES UNION, 300 kc/s, 1,000 metres; 100 kW.—10.45 a.m., Weather Forecast 1.45 p.m., Weather. 2.0, Talk. 3.30, A Sketch (Zostchenko) followed by Reading from Stanislavsky's Memoirs. 4.30, Talk: Science and Technics. 6.30, Relay of a Play (Gliesser) with Music by Trojanov. 8.0, News. 8.30, Programme Announce-

ments. 8.55, Chimes. 9.5, Press Review. 10.0, Weather.

MOTALA.—See Stockholm.

MUHLACKER.—See Stuttgart.

MUNICH

563 kc/s, 533 metres; 60 kW. Relayed by Augsburg and Kaiserslautern, 536 kc/s, 560 metres; and Nurnberg, 1,256 kc/s, 239 metres.—9.20 a.m., Laying of the Foundation Stone for the Home of German Art. Address by Hitler. 10.45, Military Band Concert. 12 Noon, Time and Programme Announcements. 12.10 p.m., Talk: Church Festivals. 12.30, Talk with Gramophone Illustrations. 1.30, Chess Lesson. 2.0, Spanisches Liederspiel—Song Cycle (Schumann). 2.30, Programme for Children. 3.0, Reading (Nietzsche). 3.20, Concert conducted by Erich Kloss. 4.40, German Art Day—A Radio Sequence. 5.40, Vocal and Instrumental Concert. 6.0, An Artists' Festival at Isar-Athen—Firing of Salvoes and Report on the Artists' Procession. 7.0, See Leipzig. 7.30, See Stuttgart. 8.0, Wagner Concert by the Symphony Orchestra, conducted by Franz Adam. 8.30, See Langenberg. 9.0, Time and News. 9.15 (approx.), Programme to be announced. 10.0, Serenade.

NAPLES.—See Rome.

NOTODDEN.—See Oslo.

OSLO

277 kc/s, 1,083 metres; 60 kW. Relayed by Fredrikstad, 315 kc/s, 368.1 metres; Hamar, 522 kc/s, 574.7 metres; Notodden, 671 kc/s, 447.1 metres; Porsgrund, 662 kc/s, 453.2 metres, and Rjukan, 671 kc/s, 447.1 metres.—9.15 a.m., News and Weather Report. 9.20, Chimes and Divine Service. 3.0 p.m., Gramophone Concert of Music by Mendelssohn, Wagner, Rachmaninov, Leoncavallo, Couperin, Verdi, Carl Bohm, de Curtis, and Beethoven. 4.0, Venner—Play in Three Acts (Arnulf Overland). 5.30, Talk: A Visit to Western Norway, relayed from Bergen, 324 kc/s, 364 metres. 6.15, Weather and News. 6.30, Talk: Before the Elections. 7.0, Time Signal. 7.1, Concert by the Station Orchestra. 8.35, Sports Notes, Weather and News. 9.0, Topical Talk. 9.15, Variety Programme. 10.0, Dance Music on Gramophone Records. 11.0 (approx.), Close Down.

OSTERSUND.—See Stockholm.

PALERMO

568 kc/s, 537.6 metres; 3 kW.—9.25 a.m., Bible Reading. 9.40, Sacred Music. 10.5, Agricultural Talk. 11.45, Giornale Radio. 12 Noon to 1.0 p.m., Light Music. In the interval at 12.30, Time, Announcements and Weather. 4.30 to 5.30, Gramophone Music. 7.0, Dopolarovo Announcements and Giornale Radio. 7.20, Gramophone Music. In the intervals at 7.25, Sports Notes, and at

OCT. 15th **SUNDAY** continued

7.30, Time and Announcements. 7.45, Symphony Concert, conducted by La Rosa Parodi: Soloist: Mammio (Pianoforte); Overture to a Comedy (Renato Parodi); Concerto Campestre for Pianoforte and Orchestra (Poulenc). In the interval, Talk: Guy de Maupassant at Syracuse. Second Symphony in D (Brahms). After the Concert, Gramophone Music. 10.0 (approx.), Giornale Radio.

PARIS

POSTE PARISIEN, 914 kc/s, 328.2 metres; 60 kW.—10.0 a.m., Gramophone Music. 10.20, Press Review. 10.30, Gramophone Music (contd.). 11.0, Concert by the Station Orchestra. 12.15 p.m., Sound Film Music on Gramophone Records. 12.45, Sponsored Programme. 12.50, Song Recital. 1.30, Gramophone Music. 2.0, Interval. 7.0, Le Journal Parle. 7.5, Sports Notes. 7.15, Gramophone Music. 7.30, Catholic Address. 8.0, Koubitzky on Gramophone Records. 8.30, Chopin and Liszt Gramophone Concert. 9.15, La Cinquantaine—Play (Courteline). 9.45, Concert. Soloists: Charlotte Davia, Roger Tréville and Laura Habas. 10.30, News.

PARIS

RADIO PARIS, Call CFR, 174 kc/s, 1,725 metres; 75 kW.—7.45 a.m., Gramophone Music. 8.0, Press Review and Weather. 8.30, Physical Culture. 12 Noon, Religious Address. 12.20 p.m., Sacred Music. Fantasia in C Minor (Bach); Pastoral (Buxtehude); Finale from the Second Symphony (Widor). 12.30, Gramophone Concert. Slav March (Tchaikovsky); Moorish Serenade (Chapi); Air and Danse negre (Scott); Aria from the Magic Flute (Mozart); Hungarian Rhapsody (Liszt); Spanish Dance (Granados); Selection from La Rédemption (Franck); Rondel de l'adieu (de Larra); The Ride of the Valkyries (Wagner); Parade of the Tin Soldiers (Jessel); Roses d'amour (Sabatier); Le Moulin de la Vierge (Blondian); Tango (Malderen); The Forge in the Black Forest (Eilenberg); Douce tendresse (Paradis). In the interval at 1.0, Exchange, News and Weather. 1.30 to 2.30, Programme in English by the I.B.C. 1.30, Gramophone Concert. Aubade printanière (Lacôme); Chanson de la Esmeralda (Mesquita); Waltz. Les taquigneurs (Waldteufel); Lettre à Manon (Gillet); Effleurement (Ganne); Bouton d'or (Pierne); Adoration (Filipucci); Joyeux retour (Avignon). 2.0, Concert of Dance Music. Signature Tune: Happy Feet; Honey, what a pleasure; Best Wishes; Siboney; Somewhere in the World; Mary Rose; My

Girl's such a good sport; Spanish Eyes; Happy Ending; Signature Tune: Happy Feet. 3.0 to 3.30, Programme in English by the I.B.C. 3.0, Orchestral Concert. Toreador Song from Carmen (Bizet); Selection from The Last Waltz (O. Straus); Selection from Rio Rita (McCarthy and Tierney); The Dancing Lesson (Oliver); Savoy Southern Memories (arr. Somers). 5.30, Gramophone Music. 6.0, Popular Concert. 7.0, Concert of Light Music. 8.0, Radio-Paris Music Hall. The Orchestra conducted by Maurice André. In the intervals at 8.30, News and Weather, and at 9.15, Press Review and News.

PITTSBURGH

KDKA, 980 kc/s, 306 metres; 50 kW. Relayed by W8XK on 48.86 metres and 25.27 metres.—7.0 p.m., Boys of Wynecastle. 7.15 to 11.0, New York Relay. 7.15, Autumn Jyll. 7.30, Popular Programme. 8.0, National Opera Concert. 9.0, Gould and Shefter. 9.15, The Morin Sisters. 9.30, Organ Recital. 10.0, Vesper Services. 10.30, Grand Hotel, from New York. 11.0, Patné News. 11.15, Weather and Sports Notes. 11.30, Happy Felton's Orchestra. 12 Midnight, Vincent Lopez Orchestra, from New York. 12.30 a.m. (Monday), Programme to be announced. 1.0 to 2.45 a.m., New York Relay. 1.0, Light Opera Nights. 2.0, Gull Headliners. 2.30, Walter Winchell. 2.45, Marvellous Melodies. 3.0 to 4.0, New York Relay. 3.0, Mountain Music. 3.15, Fireside Memories. 3.30, Green Brothers' Orchestra. 4.0, Sports Notes and News.

PORSGRUND.—See Oslo.

PRAGUE

614 kc/s, 488.6 metres; 120 kW.—8.55 a.m., Quintet in E. Op. 42, for Violin, Cello, Clarinet, French Horn and Pianoforte (Fibich). 9.30, See Moravská-Ostrava. 10.0, Concert by the Station Orchestra, conducted by Jeremias: Recitations by Zdenek Stepanek. 11.0, Chimes. 11.5, News. 11.15, See Brno. 12.30 p.m., Agricultural Programme. 1.15 to 1.25, Announcements. 3.0, See Brno. 4.30, Reminiscences of the Theatre by the Blind Actor, Bohuslav. 4.45, Gramophone Music. 5.0, German Transmission: Music Review, followed by Recital of Mediaeval Songs in Honour of the Virgin Mary, by the German University Choir. Soloist: Schwarz (Tenor). After the Programme. News. 6.0, Time and News. 6.5, See Brno. 6.40, See Bratislava. 7.30, See Moravská-Ostrava. 8.30, Saxophone Solos. 9.0, Time and News. 9.20, Gramophone Music. 10.0 (approx.), Close Down.

RADIO-SUISSE ROMANDE

SOTTENS, 743 kc/s, 403 metres, 25 kW.; and Geneva, 395 kc/s, 760 metres.—8.55 a.m. (from Geneva), Chimes. 9.0 (from Geneva), Protestant Service. 10.0 (from Geneva), Gramophone Music. 11.30, News and Weather. 11.40 (from Geneva), Gramophone Music. 1.0 to 2.0 p.m., Interval. 2.0 (from Geneva), Light Music on Gramophone Records. 4.0 to 5.0, Interval. 5.0 (from Geneva), Gramophone Music. 5.20 (from Geneva), Religious Address. 5.50 (from Geneva), Organ Fantasia and Fugue—Ad nos ad salutarem undam (Liszt), relayed from St. Joseph's Church. 6.20 (from Geneva), Radio Chronicle and Sports Notes. 7.0 (from Geneva), Talk: The Countess of Noailles and her work. 7.30 (from Geneva), 'Cello Recital by Morel. 7.55, Concert by the Radio Suisse Romande Orchestra, conducted by Echenard: Overture, The Black Domino (Auber); Waltz, Roses from the South (John Strauss); Canzonetta (D'Ambrosio); Musette and Gavotte (d'Ambrosio); Le convent (Pierne); Selection from Lohengrin (Wagner); Ballet of the Sylphs, Elini Minuet and Hungarian March (Berlioz). 9.0, News and Weather. 9.15 (approx.), Close Down.

RJUKAN.—See Oslo.

ROME

Call 1R0, 680 kc/s, 441 metres; 50 kW. Relayed by Naples, 941 kc/s, 319 metres; Milan (Vigentino), 662 kc/s, (453.2 metres from 7.45 a.m.) and 2R0, 11,810 kc/s, 25.4 metres from 4.15 p.m.—9.0 a.m., Sports Notes and Amusement Guide. 9.30, Agricultural Talk. 9.45, Bible Reading. 10.0 to 11.0, See Turin. 11.30, Musical Programme. 11.45 (approx.) to 1.0 p.m., See Turin. In the interval from 12.30 to 12.45, Sponsored Music. 1.0, Time and Announcements. 3.45 (Naples), Programme for Children, Weather and Sports Notes. 4.0, Sports Results. 4.15, Vocal and Instrumental Concert. 5.30, Weather. 6.30, Sports Notes, Dopolarovo Report and News. 6.45, Mezzo-Soprano Solos. 7.0, Time and Announcements. 7.25, Sports Notes. 7.45, Pianoforte Recital by Mario Ceccarelli: Pastorale and Gavotte (Scarlatti) Second Hungarian Rhapsody (Liszt). 8.0, Duets from the Second and Third Acts of Manon (Massenet), followed by Talk on Literature and Art. 8.50 (approx.), Gramophone Concert of Classical Music. Announcements in the interval. 10.0 (approx.), Giornale Radio and Close Down. **SALZBURG.**—See Vienna.

SCHENECTADY

WGY, 791 kc/s, 379.5 metres; 50 kW. Relayed at intervals by W2XAF on 31.48 metres and by W2XAD on 19.56 metres.—7.0 to 8.45 p.m., New York Relay. 7.0, Gene Arnold and the Commodores. 7.15, Pop Concert. 7.45, Gems of Melody. 8.0, Wayne King's

Presenting the **NEW**



DISC ATTACHMENT

-a model of Beauty and efficiency!

This illuminated Disc Attachment is suitable for use with variable condensers of all types, single or gang. The well-finished moulded escutcheon plate with knob to match is mounted on the front of the panel. The attachment is fitted to the condenser by the "one-hole" fixing method, the whole with scale being secured in rear of panel. The knob revolves in the same direction as the scale, controlling the powerful slow motion movement of ratio 7 to 1. Supplied complete with lamp holder but less lamp. Cat. No. R/365.

The Ormond No. 7 Screened Gang Condenser. Cat. No. R/490 S.3. Price 21/-

THE ORMOND ENGINEERING CO., LTD., Ormond House, Rosebery Avenue, London, E.C.1.

Telephone: Clerkenwell 5334-5-6 and 9344-5-6. Telegrams: "Ormondengi, Isling."

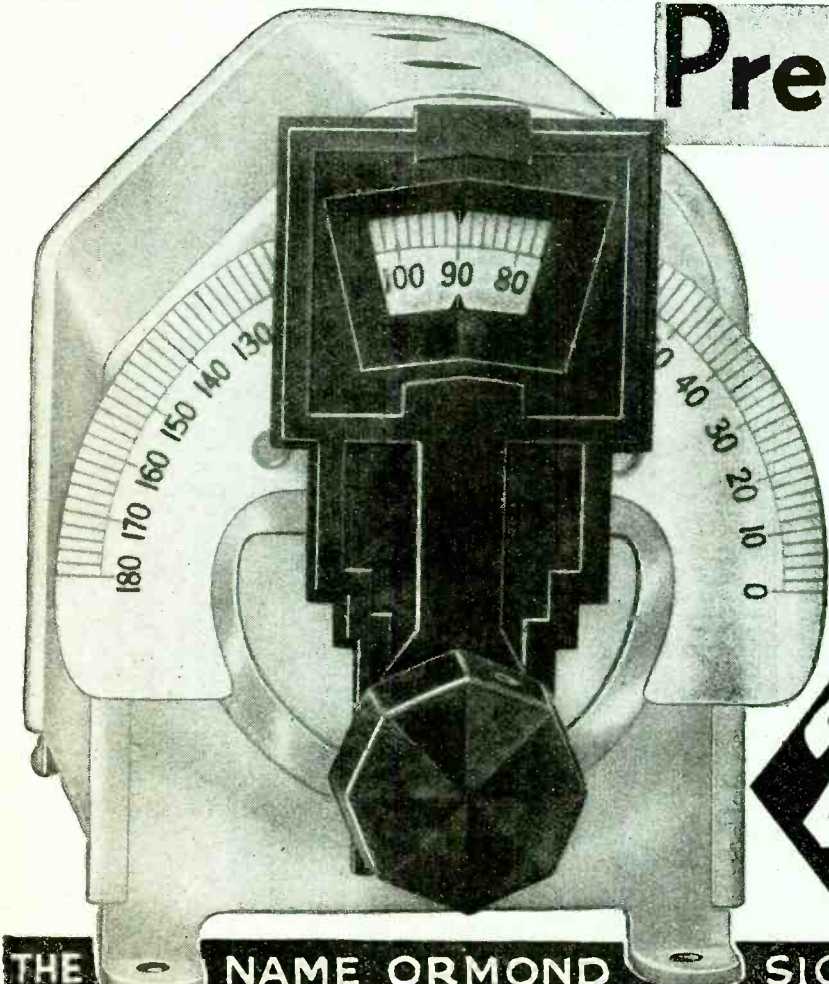

THE NAME ORMOND SIGNIFIES THE BEST BRITISH MAKE

OCT. 15th **SUNDAY** continued

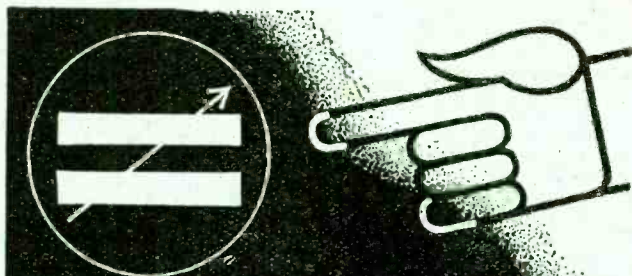

JUST ANOTHER WAY OF SAYING—

Whatever the circuit, the experienced constructor will always choose "J.B." For tuning iron-cored coils, in particular, the accurate matching found in J.B. Gangs becomes imperative; and the mechanical rigidity of "J.B." ensures the permanence of this matching.

Illustrated is the "J.B." Straight Line Dial the whole scale of which is always on view and illuminated by a lampholder which travels with the cursor. Dial only, type S.L.1, as illustrated, 6/6; type S.L.2 with switch for lamp, 7/6. J.B. Nugang with cover and dial as illustrated, 2-Gang 21/6; 3-Gang 26/6; 4-Gang 35/-.

Write for complete catalogue.

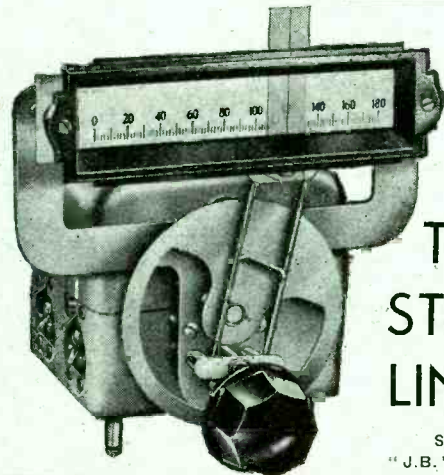

THE "J.B." STRAIGHT LINE DIAL

Shown fitted to a "J.B." Nugang Condenser

PRECISION INSTRUMENTS

Advertisement of Jackson Bros. (London) Ltd., 72, St. Thomas' Street, London, S.E.1 Telephone: Hop 1837.

Orchestra. 8.30, Radio Pulpit. 12.45 to 3.45 a.m. (Monday), New York Relay. 12.45, Variety Programme. 1.0 a.m., Popular Programme. 2.0, Manhattan Merry-Go-Round. 2.30, American Album of Familiar Music. 3.0, Variety Programme. 3.30 Impressions of Italy. 3.45, Sunday at Seth Barkers, from New York, followed by Programme Resumé.

SCHWEIZERISCHER LANDESENDER

BEROMUNSTER, 653 kc/s, 459 metres; 60 kW.; **Basle**, 1,229 kc/s, 244.1 metres; and **Berne**, 1,220 kc/s, 245.9 metres.—9.0 a.m. (from Zürich), Protestant Service. 9.45 (from Zürich), Concert. 10.30 (from Zürich), Literary Programme. 11.0 (from Zürich), Gramophone Music. 11.30, Time, Weather and News. 11.40 (from Zürich), Operetta Music by the Radio Orchestra, conducted by Neppach. 12.30 p.m. (from Zürich), Programme for Peasants—Concert by the Heimelig Orchestra. 1.0 (from Zürich), Agricultural Talk. 1.30 to 3.0, Interval. 3.0 (from Zürich), Opera Music and Light Music on Gramophone Records. 4.0 (from Zürich), Recital of Popular Songs and Folk Songs by Walter Arnold. 5.0 (from Zürich), Chess Lesson. 5.30 (from Zürich), Chamber Music on Gramophone Records. 6.0 (from Zürich), Time and Sports Notes. 6.5 (from Zürich), Ballet Music on Gramophone Records. 6.20 (from Zürich), Talk in Dialect. 7.0 (from Zürich), Concert by the Radio Orchestra. 7.20 (from Zürich), Travel Talk: Holland. 7.50, News. 8.0, Report on the Disarmament Conference, relayed from Geneva. 9.20 (approx.) (from Zürich), Sports Notes and Close Down.

SOTTENS.—See Radio-Suisse Romande.

STOCKHOLM

689 kc/s, 436 metres; 55 kW. Relayed by **Boden**, 244 kc/s, 1,229.5 metres; **Göteborg**, 932 kc/s, 322 metres; **Hörby**, 1,166 kc/s, 257 metres; **Motala**, 221.5 kc/s, 1,354.4 metres; **Ostersund**, 389 kc/s, 770 metres; and **Sundsvall**, 554 kc/s, 542 metres.—8.0 a.m., Provincial Programme. 8.30, Gramophone Music. 9.10, Talk for Workers. 9.30, Literary Talk, relayed from Malmö, 1,301 kc/s (231 metres). 10.0, Divine Service. 11.45, Weather. 2.0 p.m., Temperance Talk, relayed from **Uppsala**, 662 kc/s (453.2 metres). 2.30, Gramophone Music. 3.0, Elementary English Lesson. 3.30, Gramophone Music. 4.5 (from Sundsvall), Concert of Light Music; Tofting (Violin) and Hugo Norén (Songs). 4.30 Programme for Children, relayed from **Halmstad**, 1,391 kc/s (216 metres). 5.0, Divine Service. 6.15, Weather and News. 6.35, Concert by the Station Orchestra, the Station Choir and Soloists: Greta Söderman (Songs) and Astrid Berwald (Pianoforte). In the intervals, Sketch (Svensk) and Reading. 8.45, Weather and News. 9.0 (from Göteborg), Concert by the Kolisch String Quartet: Quartet in F (Ravel); Quartet in D (Mozart). 10.0 (approx.), Close Down.

STRASBOURG

869 kc/s, 345 metres; 11.5 kW.—9.30 a.m., Orchestral Concert, conducted by Maurice de Villers. 10.45, Protestant Service. 11.30, Catholic Service in German. 12 Noon, Gramophone Concert of Classical Music. 12.45 p.m., News. 1.0, Time Signal. 1.1, Light Music on Gramophone Records. 2.0, Agricultural Talk. 2.15, Interval. 3.0, Symphony Concert by the Conservatoire Concert Society, relayed from the Paris Conservatoire. 5.0, Orchestral Concert, conducted by Roskam. 6.0, Medical Talk. 6.15, Sports Talk. 6.30, Chamber Music: Sonata for Horn and Pianoforte (Beethoven); Sonata for Two Pianofortes (Mozart); Sonata for Violin and Pianoforte (Brahms). 7.30, Time and News. 7.45, Gramophone Music. 8.0, Press Review in German, Lottery Results and Announcements. 8.30, Alsatian Programme: Thomas Steltzer—Folk Play in Three Acts (Ernest Fuchs), with Incidental Music by Alphonse Gross. After the Programme, Press Review in French. 10.30, Dance Music, relayed from the Savoy.

STUTTGART

MUHLACKER, 832 kc/s, 360.5 metres; 60 kW. Relayed by **Freiburg**, 527 kc/s, 570 metres.—9.45 a.m. (from Karlsruhe), Music of the Rococo Period—Vocal and Instrumental Concert. 11.0, See Frankfurt. 12 Noon, Topical Talk. 12.15 p.m., Foreign Melodies on Gramophone Records. 1.15 (from Freiburg), Agricultural Talk. 1.30, See Langenberg. 2.30 (from Mannheim), Palatinate Programme. 3.0, See Langenberg. 5.0 (from Karlsruhe), Das Ert'weinfass—Play from a Tale by Carl Friedrich Wiegand. 5.40, Sports Notes. 6.0, Te deum (Edgar Tincl), relayed from St. Elizabeth's Church. 7.0, See Leipzig. 7.30, Schubert Concert by the Station Choir and Orchestra. 8.0, See Munich. 8.30, See Langenberg. 9.0, See Frankfurt. 9.20, You must know. 9.30, Local News. 9.45 to 11.0, See Frankfurt. 11.0, Serenade. 1.0 a.m. (Monday), Close Down.

SUNDSVALL.—See Stockholm.

TOULOUSE

779 kc/s, 385 metres; 8 kW.—11.0 a.m., Dance Music. 11.30, Orchestral Music. 11.45, Airs from Operettas. 12 Noon, Military Music. 12.15 p.m., Arias from Opera. 12.30, Catholic Service. 12.45, Songs from Sound Films. 1.0, Amusement Guide and Market Prices. 1.5, Orchestral Music. 1.15, Songs. 1.30, Airs from Operettas. 1.45, Popular French Music. 2.0, Music by a Viennese Orchestra. 2.15, Agricultural Report. 2.30, La Bohème—Opera (Puccini)—Concert Version. 3.30, Orchestral Music. 3.45, Accordion Solos. 4.0, Popular Songs. 4.15, Military Music. 4.30, Violin Concerto (Tchaikovsky). 5.0, Dance Music. 5.45, Melodies by an Argentine Orchestra. 6.0, News. 6.15, Opéra-Comique Airs. 6.30, Airs from Operettas. 6.45, Sponsored Concert. 7.15, News. 7.30, Orchestral Concert. 8.0, Russian Songs and Balalaika Music. 8.15, Light Music. 8.30, Opéra-Comique Airs. 8.45, Two Steps. 9.0, Extracts from La fille et le garçon—Sound Film (Gilbert). 9.20, Music by a Viennese Orchestra. 9.45, Songs. 10.0, Accordion Solos. 10.15, North African News. 10.30, Concert for Listeners in Morocco. 11.0, Music by an Argentine Orchestra. 11.15, Light Music. 11.30, Songs from Operettas. 11.45, Orchestral Pieces. 12 Midnight, News. 12.5 a.m. (Monday), Hawaiian Guitar Music. 12.15, Cinema Organ Music. 12.30 (approx.), Close Down.

TRONDHEIM.—See Oslo.

TURIN

1,096 kc/s, 273.7 metres; 7 kW. Relayed by **Milan**, 905 kc/s, 331.5 metres; **Genoa**, 959 kc/s, 312.8 metres; and **Florence**, 599 kc/s, 500.8 metres.—8.40 to 8.55 a.m., Giornale Radio. 9.40, Agricultural Talk. 10.0, Mass from the Church of the Annunciation, Florence. 11.0 to 11.15, Religious Address. 11.30, Gramophone Music. 11.45, Sponsored Music. 12.0 Noon, Time and Announcements. 12.2 p.m. (approx.) to 1.0, Orchestral Concert, conducted by Tito Petralia. 3.0, Gramophone Music. 4.0, Concert of Variety Music. In the intervals, Football Results and Sports Talk. 5.0, Sports Notes. 5.15, Weather and Gramophone Music. 6.0, Time, Football Results, Dopplavoro Announcements and Gramophone Music. 6.15, Gramophone Concert. 7.0, Announcements and Sports Notes. 7.30, Transmission of an Opera. In the intervals, Talk, Theatre Notes and Giornale Radio.

VIENNA

581 kc/s, 517 metres; 100 kW. Relayed by **Craz**, 852 kc/s, 352.1 metres; **Innsbruck**, 1,058 kc/s, 283 metres; **Klagenfurt**, 662 kc/s, 453.2 metres; **Linz**, 1,220 kc/s, 245.9 metres; and **Salzburg**, 1,373 kc/s, 218.5 metres.—10.0 a.m., Radio Report of the Unveiling of the Ziehrer Home. 10.30 a.m., Unveiling of a Memorial to the Fallen, on the Thirtieth Anniversary of the Cadet School, relayed from Traiskirchen. 11.30, Orchestral Concert, conducted by Weirich. Soloist: von Reuter (Violin). 1.30 p.m., Time and Weekly News Review. 1.45, Agricultural Talk. 2.5, Review of Books. 2.30, Concert by the Wiener Symphoniker, conducted by Josef Holzer. Soloist: Jaro Schmeid (Violin). 2.45, Commentary on the Count Kamman-Hunyadi Races from the Kriean. 3.15, Concert (cont'd.). 4.30, Talk: On American Railways. 4.55, Pianoforte Trio, in E Minor (Reger). 5.40, Gustav Festerberg reads from his own works. 6.10, Talk: Reminiscences from the Life of a Singer. 6.50, Hugo Wolf Song Recital by Rose Walter (Soprano). 7.30, That is Love—a Radio Potpourri. 9.0, News. 9.15, Dance Music on Gramophone Records.

WARSAW

212.5 kc/s, 1,411 metres; 120 kW.—10.57 a.m., Time Signal and Fanfare from St. Mary's Church, Cracow. 11.5, Programme Announcements. 11.10, Weather. 11.15, Tchaikovsky Concert by the Philharmonic Orchestra: Soloist: Kochanski (Violin). In the interval at 12 Noon, Talk: Safety First in the Factory. 1.0 p.m., Agricultural Talk. 1.15, Agricultural Prices. 1.20, Gramophone Records. 2.0, Veterinary Talk. 2.20, Concert by the Arcadian Bukin Quintet. In the Interval, Announcements. 3.0, Programme for Children, relayed from Cracow, 959 kc/s (312.8 metres). 3.30, Song Recital on Gramophone Records. 3.45, Reading. 4.0, Talk for Women. 4.15, Popular Programme, relayed from **Katowice**, 734 kc/s (408 metres). 5.0, Programme to be announced. 5.40, Song Recital, relayed from **Poznan**, 896 kc/s, (335 metres). 6.5, Miscellaneous Items. 6.25, News. 6.30, Weekly Review for Young People. 6.45, Programme announcements. 6.50, Radio Journal. 7.0, Concert by the Station Orchestra, conducted by Nawrot. 8.0, Topical Talk. 8.15, Humorous Programme, relayed from **Lwow**, 788 kc/s (581 metres). 9.15, Sports Notes. 9.25, Dance Music from the Ziemianska Café. 10.0, Weather and Police Notes. 10.5, Dance Music (cont'd.).

ZURICH.—See Schweizerischer Landessender.

MONDAY

OCTOBER THE SIXTEENTH

ATHLONE

725 kc/s, 413 metres; 60 kW. Relayed by Cork, 1,337 kc/s, 224.4 metres.—1.30 to 2.30 p.m., Time, Weather, Stock Report, and Gramophone Music. 6.0, Programme for Children. 6.45, News. 7.0, Gaelic Talk. 7.15, Folk Tales. 7.30, Time Signal. 7.32, Acusla—by T. Madden and Company, with the Station Orchestra. 8.30, Violin Solos by Una Kenny. 8.45, Contralto Solos by Florence Howley. 9.0, Talk. 9.15, The Station Orchestra. 9.30 to 10.30, Programme by the I.B.C. (Ireland), Ltd. 9.30, Concert of the Morning (Leclercq); In the Park in Páree (Bainger); The Moment I saw you (Gay); Can't we meet again (Elanagan). 9.45, Octet Music. Hindu Song from Saldko (Rimsky-Korsakov); Cradle Song (Grieg); "Wireless World" Announcement; Violin Solo, Melodie (Kreisler); Mock Morris (Grainger) 10.0, Concert arranged by the International Broadcasting Company (Ireland), Ltd., on behalf of the Irish Hospitals Sweepstake Authorities. Don't be late in the Morning (Leclercq); Maria my Own (Lecount); My Love Song (Burnaby); Racing Commentary; Sunny Madeira (Gilbert); The Whisper Waltz (Burke); Stormy Weather (Arden); Good-night but not good-bye (Miehn). 10.30, I.B.C. Good-night Melody, followed by News and Weather. 10.40, The Columille Ceilidhe Band. 11.0 (approx.), Close Down.

BARCELONA

EAJ1, 860 kc/s, 348.8 metres; 8 kW.—6.0 p.m., Trio Concert. Selection from Lilac Time (Schubert-Berté); Evening Song (Rabey); Spanish Serenade (Glaunov); Norwegian Dance No. 2 (Grieg); Bureoulet, Venetian Gondolas (Leemans); Minuet (Bocherini); Selection from Rienzi (Wagner). 7.0, Request Gramophone Music. 7.15, Talk on Hygiene. 7.20, Sports Talk. 7.30, Exchange and Talk in Catalan. 8.0, Gramophone Music and News. 9.0, Chimes from the Cathedral, Weather, Exchange and Market Prices. 9.5, Humorous Review of the Week in Verse. 9.15, Concert of Sardanas. 10.0, Violin and Pianoforte Recital. 10.30, Catalan Radio Gazette. 11.0, News. 11.10 (approx.), Concert by the Station Orchestra. Overture, The Ruins of Athens (Beethoven); Suite, El secreto de Myrto (Berardi); Selection from Der Rosenkavalier (R. Strauss). 12 Midnight (approx.), Close Down.

BARI

1,112 kc/s, 269.8 metres; 20 kW.—11.30 a.m. to 1.0 p.m., Concert by the Radio Quintet. 1.0, See Rome. 3.30, Gramophone Music. 4.10 (approx.) to 5.35, See Rome. 5.35, News in Albanian. 5.45 (approx) till Close Down, See Rome.

BASLE.—See Schweizerischer Landessender.

BELGRADE

697 kc/s, 430.4 metres; 2.8 kW.—5.55 p.m., Time Signal. 5.56 (approx.), Concert by the Radio Orchestra. 7.0, Address. 7.30, Faust—Opera (Gounod) from the National Theatre. In the interval at 9.0, Time and News.

BERLIN

DEUTSCHLANDSENDER (Reichssender), 183.5 kc/s, 1,635 metres; 60 kW.—11.5 a.m. (approx.), Gramophone Concert: Folk Song, Es ritten drei Reiter zum Tor hinaus; Third Waltz Potpourri (Robrecht); Noch sind die Tage der Rosen (Baumgarten); Song, Es muss ein Wunderbares sein (Liszt); Overture, Donna Diana (Reznicek); Song from Der arme Jonathan (Müllcker); Two Alsatian Peasant Dances (Merklng); Wanderlieder-Potpourri; Tarantella, La danza (Rossini); Waltz Melodies (Chopin); Selection from Carmen (Bizet); Song (Tosti). 11.55, Time. 12 Noon, Interval. 12.45 p.m., News. 1.0, Gramophone Concert: Overture, Hans Heiling (Marschner); Minuet (Bocherini); Waltzes Nos. 1, 2 and 15 (Brahms); Hungarian Dances Nos. 6 and 7 (Brahms); Minuet from the Divertissement in D (Mozart); Three Contredanses (Mozart); Selection from Siegfried (Wagner); Selection from The Twilight of the Gods (Wagner); Ecossaises (Beethoven); Waltz and Ballet Music from Faust (Gounod); Overture, Preciosa (Weber); Selection from La Bohème (Puccini). 2.0, Talk for Women. 2.30, Weather and Exchange. 2.45, Review of Das Kaiserbuch (Paul-Ernst). 3.0, Concert from Breslau. 4.0, Talk: The Future of the Education of Girls in Germany. 4.25, Unfamiliar Weber Music—Recital by Risa von Hessert (Songs), Rolf Ermeler (Flute), Hans Schröder (Viola and Violin), Bruno Hentze (Guitar), Peter Lehmann (Cello), and Maria Ermeler-Lortzing (Pianoforte). Minuet for Flute, Viola and Guitar; Three Scottish Songs, with Flute, Violin, Cello and Pianoforte: (a) Bewunderung, (b) Szene im Mondschein, (c) Ein altes Ehepaar; Sicilian Romance for Flute and Pianoforte; Three Scottish Songs: (a) Der fröhliche Soldat, (b) Das lebenswürdige und standhafte Mädchen, (c) Der Troubadour; Trio in G Minor for Flute, Cello and Pianoforte. 5.0, Poems. 5.5, Talk: Health Services in the Hitler Jugend Movement—Radio Report from the Berlin Charité—Speeches by the Minister of Health and Others. 5.45, Weather and Announcements. 6.0, Transmission for all German Stations, relayed from Munich. 7.0, To-day's Motto.

7.5, Request Concert on Gramophone Records: Marching Song, Deutscher Pöbn; The Blue Danube (Joh. Strauss); Giovinetta; Largo (Handel); Tarantella; Waltz from Coppélia (Delibes); Marie Louise (Meisel); Selection from Wild Violets (Stolz); Schöne Isabella von Castilien (Boottz); Ich hab' dich einmal geküsst (Lehár); Song of the Torador from Carmen (Bizet); Ultima Serenata (Magnani-Alfy); Badenweiler-Marsch (Fürst). 8.15, Cabaret Programme. 9.0, News. 9.15 (approx.), Dialogue: The Parachute. 9.45, Weather. 10.0, See Leipzig. 11.0 (approx.), Close Down.

BERLIN

FUNKSTUNDE, 715 kc/s, 419.5 metres; 1.5 kW.—3.30 p.m., Concert from the Zoological Gardens: Overture, Titus (Mozart); Poème (Fibich); Rose mousse (Bosc); Waltz, Fische Geister (Ed. Strauss); Tarantella amorosa (Panizzi); Intermezzo, Vergissmeinnicht (Macbeth); Waltz, Nur einen Sommer lang (Kollo); Tango, A Hundred Thousand Women (Lesso-Valerio); Foxtrot, Draussen in der Welt (Borgmann); Intermezzo, Nurrissenmüdel (Siede); Potpourri, Wiener Volksmusik (Kozzak). 4.30, Dialogue on Popular Melodies, relayed from a Café. 4.50, Reading by Hans Henning Baron Grote. 5.10, Violin Sonata in A Minor, Op. 105 (Schumann). 5.30, The Funkstunde informs its Listeners. . . . 5.45, Topical Talk. 6.0, Transmission for all German Stations, relayed from Munich. 7.0, Lottery Announcements. 7.5, Genius and Heredity—Literary and Musical Programme about the Bach Family, the Mozarts, Matthias Claudius, his Grandson, and his Great-Granddaughter, Richard and Siegfried Wagner, and the Strauss Family. Talk by Gottfried Beim: Talent can be bred, followed by a Discussion. 9.0, News. 9.15 (approx.), Dance Music from the Zoological Gardens. In the interval from 10.0 to 10.5, A Warning by the Chief of Police. 11.0 (approx.), Close Down.

BERNE.—See Schweizerischer Landessender.

BEROMUNSTER.—See Schweizerischer Landessender.

BODEN.—See Stockholm.

BODO.—See Oslo.

BORDEAUX-LAFAYETTE

986 kc/s, 304 metres; 13 kW.—6.15 p.m., Radio Journal. 7.30, News, Racing Results and Market Prices. 7.35, Talk: Bordeaux a Century ago. 7.50, Lottery Results. 8.0, Talk on Social Hygiene. 8.15, News. 8.30, Concert of Classical and Modern Music.

BRATISLAVA

1,076 kc/s, 279 metres; 14 kW.—4.5 p.m., Song and Aria Recital by Marie Tauberová-Proskeová. Songs from Die tote Stadt (Kornfeld), The Force of Destiny (Verdi), Der Bettelstudent (Müllcker), Eva (Lehár), Schön ist die Welt (Lehár). A Kiss in Spring (Kálmán), Frederica (Lehár), Sissy (Kreisler). 4.40, Talk. 4.55, Sonata Recital by Náhlovsky (Violin) and Kafenda (Pianoforte). Sonata No. 2 in D Minor (Schumann); Sonata in C Minor (Grieg). 5.55, Hints for Housewives. 6.0, See Prague. 6.10, Talk: Crime and Society, relayed from Kosice, 1,022 kc/s, 293 metres. 6.25, See Brno. 7.25, The School—Radio Comedy (Kosta Trirkovitch). 8.0, See Brno. 9.0 till Close Down, See Prague. 9.15 (approx.), Close Down.

BREMEN.—See Hamburg.

BRESLAU

923 kc/s, 325 metres; 60 kW. Relayed by Gleiwitz, 1,184 kc/s, 253 metres.—12 Noon, Gramophone Concert: March from Der Freikorporal (Vollertinn); Waltz, Dorfschwalben aus Oesterreich (Jos. Strauss); Russian Fantasia (Benedict); Starry Night (de Micheli); Renaissance (De Micheli); Gitarrenständchen (Lincke); Melodies from Mexico (Livschakov); Melody (F. Wolf); Nights in Naples (Zamecnik); Erbsen mit Speck (Wintermeier). 12.45 p.m., Time and News. 1.10, Song Recital by Anni Grosser-Klose (Soprano): Two Songs (Franz): (a) Im Herbst, (b) Willkommen, mein Wald. Three Songs (Schumann): (a) Widmung, (b) Au den Sonnenschein, (c) Ich wandre nicht. Three Songs (Brahms): (a) An die Nachtigall, (b) Botschaft, (c) Vergebliches Ständchen. Two Songs (Pfitzner): (a) Wie Frühlingsgung, (b) Gretel. 1.35, Gramophone Concert: Overture, Banditenstreich (Suppé); Abschied von der Puzta (Jeno); Strahlende Augen (Pete); Kirchweih in Tyrol (Krome); Un peu d'amour (Silesu); Ständchen (Livschakov); March (Chabrier). 2.0, Market Prices. 2.45, Review of New Editions of Luther's Works. 2.35, Talk: The Wonder of the World. 3.0, Concert by the Station Orchestra, conducted by Rischka: Festival Overture (Leutner); Lyric Suite Nos. 1 and

2 (Grieg); Schubert Potpourri (Fetras); Invitation to the Dance (Weber); Gavotte (Schütt); Homage March (Liszt). 4.0, Talk. 4.20, Market Prices. 4.35 (approx.), Legal Talk. 4.45, Topical Talk. 5.0, Concert by the Station Orchestra, conducted by Rischka: Suite der Freude (Scheinpflug); Waltz, Die ersten Gedanken (Lammer); Selection from Marke von Nymwegen (d'Albert); Musikalische Neckereien (Worch). 5.50, Meat Market Prices. 6.0, Transmission for all German Stations, relayed from Munich. 7.0, News. 7.10, Symphony Concert from the Konzertians. The Silesian Philharmonic Orchestra, conducted by Hermann Behr. Soloist: Lore Hoffmann (Soprano): Suite in Old Style, Op. 93 (Reger); Two Hymns for Soprano and Orchestra, Op. 71 (Richard Strauss); Overture, Geneva (Schumann); Three Pieces from The Damnation of Faust (Berlioz); Waltz, Morgenblätter (Joh. Strauss). In the interval from 8.0 to 8.10, News. 9.0, See Munich. 9.20, Time and News. 9.45, Wireless Technical Talk. 9.55, Reading. 10.15 (approx.), Close Down.

BRNO

878 kc/s, 342 metres; 35 kW.—5.25 p.m., German Transmission: News and Reading. 6.0, See Prague. 6.10, Talk: Crime and Society, relayed from Kosice, 1,022 kc/s, 293 metres. 6.25, Radio Revue. 7.25, Reading. 7.40, Pianoforte Recital. 8.0, Judith—Cantata for Soloists, Choir and Orchestra (Honegger), relayed from the Stadium. 9.0, See Prague. 9.30 (approx.), Close Down.

BRUSSELS (No. 1)

I.N.R., 590 kc/s, 509 metres; 15 kW.—12 Noon, Acts I and II of Il Trovatore—Opera (Verdi) on Gramophone Records. 1.0 p.m., Le Journal Parlé. 1.10, Jazz Music on Two Pianofortes. 1.30, Gramophone Music: Sous bois (Staub); Scandinavian Dance (Runo); Selection from Louis XIV (Parès and Van Phary); Song of the Volga Boatmen (arr. Chaliapine); Selection from Ever Green (Rodgers); Spanish March, Granada (Garcia). 5.0, Variety Music by the Radio Orchestra, conducted by André. 6.0, Medical Talk. 6.15, Finale of The Valkyrie (Wagner) on Gramophone Records. 6.30, Violin Sonatas by Mme. Likoudy-Passet: Sonata No. 18 (Mozart); Sonata No. 3 (Bach); Sonata in F (Tcherepnin). 7.15, Gramophone Music: Overture, The Caliph of Bagdad (Boieldieu); La promenade en voiture (Alix); Hungarian Dance (Barthel); Minuet (Boëllmann). 7.30, Film Review and Theatre Notes. 8.0, Concert of Ballet Music by the Radio Orchestra, conducted by Franz André: Ballet Music from Faust (Gounod), Lakmé (Delibes) and The Damnation of Faust (Berlioz); Ballet Suite, La boîte à jousjoux (Debussy); Extracts from Cendrillon (Masset); Ballet Music from Les deux pigeons (Messager). In an interval at 8.45, Reading (Broedcoerens). Extracts from La Guitarra (Pedrell). 10.0, Le Journal Parlé.

BRUSSELS (No. 2)

N.I.R., 887 kc/s, 338.2 metres; 15 kW. Programme in Flemish.—12 Noon, Gramophone Concert: Selection from Princess Charming (Waller); Waltz, Die Schönbrunner (Larner); Honeysuckle (Mayerl); Selection from One Hour with You (Robin-Whiting-Strauss); Second Serenade (Heykens); Potpourri of Russian Gipsy Melodies; Tarantella (Coates); Selection from The Maid of the Mountains (Fraser-Simson); Mignonette (Mayerl); The Skaters' Waltz (Waldteufel); Puppenparade (Rathke); Selection from Louise (Chapentier). 1.0 p.m., Journal Parlé. 1.10, Extracts from The Barber of Seville (Rossini) on Gramophone Records. 5.0, Concert by the Station Symphony Orchestra, conducted by Kumps: Overture, Preciosa (Weber); Selection from Marouf (Rabaud); Extracts from La Captive (Gillon); Humoresque (Wambach); Suite in Old Style (Blockx). 5.45, Programme for Children. 6.30, Fourth Symphony (Tchaikovsky) on Gramophone Records. 7.12, News. 7.45, Talk and Sports Review. 7.50, Journal Parlé. 8.0, Extracts from The Mastersingers—Opera (Wagner) on Gramophone Records. 8.15, Extracts from Heime—Lyric Talk (Jef Menneken), with Introductory Talk. 8.45, Talk: Belgium's Fiscal Policy. 9.0, Concert by the Station Symphony Orchestra, conducted by Kumps: Waltz, The Blue Danube (Strauss); Ballad No. 2 (Pelemans); Valse bleue (Margis); Fête populaire from La Pacification de Gand (Benoit). 10.0 Journal Parlé.

BUCHAREST

761 kc/s, 394 metres; 12 kW.—4.0 p.m., Concert by the Station Orchestra. Overture, Fra Diavolo (Auber); Ballet Music from La Juive (Halévy); Slow Waltz from The Circus Princess (Kálmán); Russian Dance (Bollinger); Waltz (Prozavnik); Rondino (Sibelius); Paysage de France (Chantrier); Madrigalesca (Albergoni). In the interval at 5.0, Radio Journal. 6.0, Educational

Programme. 7.0, Pianoforte Recital by Mme. Zamfiresco. 7.30, Talk. 7.45, Old Romanian Songs by Mme. Iordanovici. 8.15, Concert by the Metzner Quartet. 8.45, Radio Journal. 9.0, Light Music relayed from a Restaurant.

BUDAPEST

545 kc/s, 550.5 metres; 18.5 kW.—Also relayed on 840 metres from 7.30 p.m. till Close Down.—4.30 p.m., Gramophone Concert. 5.30, German Lesson. 6.0, Concert by the Emmerich Magyar Cigány Band. 7.0, Programme of Poetry and Music. 7.30, The Ninth Symphony (Beethoven), by the Concert Orchestra, conducted by Erich Kleiber, relayed from the High School for Music. 9.25, News. 9.45 (approx.), Concert by the Kari Bura Cigány Band, relayed from the Ketter Restaurant.

CASSEL.—See Frankfurt.

COPENHAGEN

1,067 kc/s, 281 metres; 0.75 kW. Relayed by Kalundborg, 260 kc/s, 1,153.8 metres.—11.0 a.m., Town Hall Chimes. 11.2, Concert by the Harald Andersen String Ensemble, relayed from the Hotel d'Angleterre. 1.0 p.m., Interval. 2.20, Talk for the Housewife. 2.30, Concert by the Radio Orchestra, conducted by Gröndahl. Overture, Jean de Paris (Boieldieu); Selection from the Music to a Play (Scarlattini); Waltz, Barcarolle (Waldteufel); Dance from Wayland the Smith (Henriques); Overture, Renaissance (Lange-Müller); March Fanfarenklänge (Fucik); Waltz, Pomona (Lumbye); Suite, Scènes napolitaines (Masset); Icelandic Dance (Lofis); Caprice italien (Tchaikovsky). In the interval at 3.15 (approx.), Reading. 4.30, Exchange and Fish Market Prices. 4.45, Talk: The Little Entente. 5.15, Elementary English Lesson. 5.45, Weather. 5.54, Announcements for the Workers' Radio Society. 6.0, News. 6.15, Time Signal. 6.20, Discussion on Newspapers. 8.0, Concert by the Radio Orchestra, conducted by Mahler. Overture, Così fan Tutte (Mozart); Divertimento (L. Mozart); Three German Dances (Mozart); Overture, A Midsummer Night's Dream (Mendelssohn); Minuet and Serenade in D (Brahms); Waltz from Der Rosenkavalier (Strauss). 9.0, News. 9.15, Gramophone Music. 9.30, Concert of Chamber Music. Quintet for Pianoforte, Flute, Clarinet, Horn and Bassoon (Rimsky-Korsakov); Divertissement for Flute, Oboe, Clarinet, Horn, Bassoon and Pianoforte (Roussel). 10.0 (approx.), Close Down.

CORK.—See Athlone.

DANZIG.—See Heilsberg.

DRESDEN.—See Leipzig.

FECCAMP

1,328 kc/s, 225.9 metres; 10 kW.—11.0 a.m. to 12 Noon, Programme in English by the I.B.C. Happy Hour: Part I. Orchestral Concert: Signature Tune; Waltz, Très jolie (Waldteufel); Song, Throw open wide your Window (Calson); Poupée valsante (Poldini); Reconciliation (Drigo); Now I'm in Love (Shapiro); Babes in Toyland (Herbert); Song, Love is King To-day; Siciliana (Schmalstieg). Part II. Dance Music: Sweet Dreams, Pretty Lady; Carry me back to Green Pastures; I always keep my Gipsy out late; With my Guitar and you; Let's call it a Day; Learn to croon; Adorable; Chewing Gum; Signature Tune. 12 Noon, Programme in French. 4.30 to 6.0 p.m., Programme in English by the I.B.C. 4.30, The Nursery Corner. 5.0, Concert for Cliechester and Bognor Listeners: Signature Tune; The Night by the Sea; Beautiful (Gillespie); Song, Letting in the Sunshine (Gay); All over Italy (Munroe); Song, That's my Home (Rene); Pianoforte Solo: Selection from The Desert Song (Sternberg); Any Time, any Day, anywhere (Washington); Polly (Zamecnik); Rosa Mia (Guizar). 5.30, Orchestral Concert for Hastings and Easthorne Listeners: Selection from Sari (Kálmán); Evolution of Dixie (Lake); Violin Solo: The Morning Star (Traditional); Ay, Ay, Ay (Frier); Charming Episode (Ormandy); Violin Solo: Moment musical (Schubert); Singing a Song to the Stars (Meyer); Southern Rhapsody (Hosmer); Signature Tune. 6.0, Programme in French. 10.0 (approx.) till Close Down, Programme in English by the I.B.C. 10.0, Dance Music: Signature Tune; Bells of Normandy; Tick Tock; A Woman should stick to her Man; Sundown in a Little Green Hollow; Nobody's Sweetheart; At the Old Pig and Whistle; Walking in a Dream; Let's Sunday down in Carolina; Isn't it Heavenly; Learn to croon; I raised my Hat; Lover; Sweetheart Darlin'; Oh! Johanna; I live for Love; Pink Elephants; Sweet Dreams; Pretty Lady; Signature Tune. 11.0, Times from the Talkies; Signature Tune; Sittin' in the Dark; The Good Companions; Tick Tock (Vienna); I've found the Right Girl; Old Talkie Gems; Everyone says I love you; One Little Drink; Pianoforte Solo: Selection from The King of Jazz; Learn to croon; Signature Tune. 11.30, Club Concert for Canterbury Listeners: Signature Tune; The Chum Song; Waltz from The Sleeping Beauty (Tchaikovsky); Intermezzo from Cavalleria rusticana (Mascagni); Scherzo from A Midsummer Night's Dream (Mendelssohn); Pilgrims' Chorus from Tannhäuser (Wagner); Idylle Bretonne (Gennin); Liebestraum (Liszt); Meditation

OCT. 16th

MONDAY

continued

from Thais (Massenet); Scarf Dance (Chaminade). 12.5 a.m. (Tuesday), Late News Bulletin in English. 12.10, Club Concert, Part II: Little Lady; Shoo the Hoodoo away; My Heart's to let; I lost my Girl from Memphis; Will you dance through Life with Me; Signature Tune. 12.30, Dance Music: Let's call it a Day; From me to you; Meet me in the Gloaming; P.C. 128, The Policeman's Song; Reflections in the Water; Maybe I love you too much; Down in the Valley; Happy Ending. 1.0, Dance Music: Signature Tune; Bells of Normandy; Lazybones; Wedding of the Dragonflies; Let's all be happy Together; Spanish Sweetheart; Won't you stay to Tea?; The Dicty Glid; My Lucky Day; They all do the Rumba; It was a Night in June; Twelfth Street Rag; The Old Spinning Wheel; I always keep my Girl out late; Avalon; I cover the Waterfront; Dancing Butterfly; Peter, Peter; Little Miss Muffett. 2.0, I.B.C. Good-night Melody and Close Down.

FLENSBURG.—See Hamburg.

FLORENCE.—See Turin.

FRANKFURT

1,157 kc/s, 259.3 metres; 17 kW. Relayed by Cassel and Trier, 1,157 kc/s, 259.3 metres.—12.15 p.m., Time and News. 12.25, Local News and Weather. 12.35 to 1.30, See Stuttgart. 2.30, Weather. 2.40, Time and Economic Notes. 3.0, Concert by the Station Orchestra. Soloists: Heinz Korte (Clarinet) and Gustav Jung (Bassoon). Part I. Conductor: Reinhold Merten. Symphony No. 3 in D (Schubert); Clarinet Concerto (Mozart); Twelve German Dances (Haydn); Bassoon Concerto (Fogg); Overture in D (Schubert). Part II. Conductor: Walter Caspar. Old Dance Music. 5.0 to 5.35, See Stuttgart. 5.35, Talk for the Housewife. 5.50, News. 6.0, Transmission for all German Stations, relayed from Munich. 7.0, Topical Talk. 7.10, Gala Concert, relayed from the Frankfurt Radio Exhibition. 9.0, News. 9.20, See Stuttgart. 9.30, News. 9.40 till Close Down, See Langenberg.

FREDRIKSSTAD.—See Oslo.

FREIBURG.—See Stuttgart.

GENEVA.—See Radio-Suisse Romande.

GENOA.—See Turin.

GLEIWITZ.—See Breslau.

GOTEBORG.—See Stockholm.

GRAZ.—See Vienna.

HAMAR.—See Oslo.

HAMBURG

806 kc/s, 372 metres; 1.5 kW. Relayed by Bremen, 1,112 kc/s, 269.8 metres; Flensburg, 1,319 kc/s, 227.4 metres; Hanover, 530 kc/s, 566 metres; and Kiel, 1,292 kc/s, 232.2 metres.—6.0 p.m., Transmission for all German Stations, relayed from Munich. 7.0, Concert by the Philharmonic Orchestra, conducted by Eugen Papst, relayed from the Musikhalle. Soloist: Prof. Gustav Havemann (Violin); Symphonie Prologue to Oedipus Rex (Max von Schillings); Concerto in D Op. 61 (Beethoven); Symphony No. 7 in E (Bruckner). News in the interval. 9.0, News. 9.10 (from Kiel), Orchestral Concert, conducted by Hans Döring. Overture, Indra (Flotow); Selection from Undine (Lortzing); Selection from Mascarade (Nielsen); Potpourri, Wien bei Nacht (Kozak); Waltz, Marienklänge (Jos. Strauss); Two Pieces (von Blon): (a) Wellenspiel. (b) Traumweben; Dance of the Dervishes (Bendix); Selection from The Geisha (Jones); Waltz, Hesperusklänge (Gungl); Nachtigallenständchen (Klose); March, Das neue Deutschland (Zimmer).

HANOVER.—See Hamburg.

HEILSBURG

1,085 kc/s, 276.5 metres; 60 kW. Relayed by Danzig, 662 kc/s, 453.2 metres.—12.15 to 1.30 p.m., Operatic Concert on Gramophone Records: Overture and Aria from Aida (Verdi); Aria and Dance of the Priestesses from Aida (Verdi); Preludes to the First, Second and Fourth Acts of Carmen (Bizet); Flower Song from Carmen (Bizet); March and Ballet Music from Robert le Diable (Meyerbeer); Overture, Rienzi (Wagner). In the intervals at 12.20 and 1.0, News. 1.40, Handicraft Lesson for Boys. 2.0, Market Prices and Exchange. 2.30, Programme for Children. 3.0, Concert by the Small Station Orchestra, conducted by Eugen Wilcken: Overture, Albin (Flotow); Scènes pittoresques (Massenet); Selection from Das Hofkonzert (Scheinflug); Waltz, Soiree las Olas (Rosas-Pachernegg); Gipsy Idyll (Percy); Brise de mer (Leonavallo); Suite, The Merchant of Venice (Sullivan); Selection from Countess Maritza (Kálmán). In the interval at 3.50, Talk: Alfred Nobel. 4.50 (from Danzig), Talk: The Mission of the Danzig Press. 5.15, Market Prices. 5.20, Talk: Through the Baltic Countries to the Grave of Walter Flex. 5.50, Weather. 6.0, Transmission for all German Stations, relayed from Munich. 7.0, News and Weather. 7.10, Concert of Ballet Music by the Small Station Orchestra, conducted by Eugen Wilcken: Ballet Overture (Kremser); Selection from Sylvia (Delibes); Frau Luna (Lincke); Macbeth (Verdi) and Undine (Lortzing). 8.0, Concert by the

Danzig Theatre Orchestra, conducted by Erich Orthmann, relayed from the State Theatre, Danzig. Soloist: Dusolina Giannini (Songs). Aria: Sut queste sacro altare, from La Vestale (Spontini); Suicidio—Aria from La Gioconda (Ponchielli); Suite, Italia (Casella). 9.0, News. 9.20, Elementary English Lesson.

HILVERSUM

1,013 kc/s, 296.1 metres; 7 kW. up to 5.40 p.m., and 20 kW. from 5.40 p.m.—11.40 a.m. till Close Down, Programme of the Workers' Radio Society (V.A.R.A.). 11.40, Concert of Light Music, conducted by Wms. 1.40 p.m., Interval. 2.10, Concert by the Little V.A.R.A. Orchestra, conducted by Hugo de Groot. In the interval at 2.40, Recitations. 4.10, Programme for Children. 4.40, Concert by De Flierefluiter, conducted by v.d. Horst. Soloist: de Booy (Songs). Schön ist das Leben (Heymann); Du, du, du (Stolz); Kleine Liebe grosse Liebe (Grothe); Butterflies in the Rain (Reaves); How deep is the Ocean? (Berlin); Going, going, going (Baxter); Yo-Yo (Nelson). 5.5, Organ Recital by Steyn: Please (Rainger); Selection from Drei alte Schachteln (Kollo). 5.15, Orchestral Concert (cont.): Bravo, bravo (Dostal); Extracts from Forty-second Street (Warren); I can't give you anything but Love (Fields); Under my Umbrella (Flynn-Meyer); Signorina (Jurmann). 5.58, Organ Recital (cont.): Ninon, lach mir einmal zu (Jurmann-Kaper); Bravo, bravo (Dostal). 5.50, Orchestral Concert (cont.): Waltz, The Blue Danube (Joh. Strauss); Play, Fiddle, play (Deutsch-Altmann); Ninon, lach' mir einmal zu (Jurmann); Lazy Bones (Carmichael); Moths around the Candle (Dolphe-Gordon); Kamerad, wir sind die Jugend (Solz). 6.10, Concert by the B.P.S. Trio, with Commentary: Trio in B Flat No. 6 (Mozart); Trio (Voomolen); The Dumky Trio (Dvorak). 6.50 (in an interval), Book Review. 7.40, S.O.S. Messages. 7.42, News. 7.55, The Barber of Seville—Opera (Rossini). In the interval at 9.30, Dramatic Programme. 10.45, Gramophone Music. 11.40 (approx.), Close Down.

HORBY.—See Stockholm.

HUIZEN

160 kc/s, 1,875 metres; 7 kW. (until 3.40 p.m.). Transmitted from Kootwijk on 50 kW. from 3.40 p.m.—Programme of the Christian Radio Society (N.C.R.V.).—11.55 a.m., Gramophone Music. 12.10 p.m., Organ Recital by Jan Zwart. 1.40, Broadcast for Schools. 2.15, Gardening Talk. 2.55, Dressmaking Lesson. 3.40, Bible Reading with Baritone and Organ Solos. 4.40, Recital by Mulder-Belser (Mezzo-Contralto), Wittpenn (Flute) and Hengeveld (Pianoforte); Ach, unaussprechlich ist die Not (Bach); Flute Sonata (Amalia Princess of Prussia); Wonne der Wehmüt (Beethoven) Die Trommel gerührt (Beethoven); Freudvoll und leidvoll (Beethoven); Etudes 1 and 6. Op. 37 (Bühm); Pianoforte Solo: Rhapsody in E Sharp, Op. 118 (Brahms); Ecoute la Symphonie (Dubois); Romance (Saint-Saëns); Novembre (Trémisot); Softly awakes my Heart, from Samson and Delilah (Saint-Saëns); Ballad in G Minor (Brahms); Intermezzo (Brahms); Herbststimmungen (Tierie Junior); Vondelingakens (Wierds); O Gulden Hoofd (Dyserinck). 6.10, Answers to Correspondence. 6.40, Police Notes. 6.55, Religious Report. 7.10, Answers to Correspondence. 7.40, Organ Recital by van den Kerckhof: Prelude in B Minor (Bach); Prelude, Christ unser Herr zum Jordan kam (Vivaldi-Bach); Prayer (Franck); Choral No. 3 (Andriessen); Carillon (Vierne); Divertissement (Vierne); Kyrie eleison (Reger); Tocata (Reger). 8.40, Religious Address. 9.10, Baritone Song Recital by Ravelli: Per la gloria (Buononcini); Come raggio di sol (Caldara); Air (Bach); Serenade from Don Giovanni (Mozart). Gramophone Music: Songs (Schubert): (a) Who is Sylvia?, (b) Gruppe aus dem Tartarus, (c) Lachen und weinen, (d) Nacht und Träume, (e) An die Leier. Gramophone Music: Songs (Brahms): (a) Ruhe Süßliebchen, (b) O wüsst' ich doch den Weg zurück, (c) Feldensamkeit, (d) Botschaft. 10.10, News. 10.20, Gramophone Music. 11.10 (approx.), Close Down.

INNSBRUCK.—See Vienna.

KALUNDBORG.—See Copenhagen.

KIEL.—See Hamburg.

KLAGENFURT.—See Vienna.

KOSICE.—See Prague.

LAHTI

167 kc/s, 1,796 metres; 40 kW. Relayed by Helsinki, 815 kc/s, 368.1 metres.—4.0 p.m., Harp Recital by Irma Lönnroth. 4.15, Talk. 5.15, English Lesson. 5.40, Talk. 6.5, Concert by the Radio Orchestra, conducted by Toivo Haapanen, relayed from the Conservatoire: Prelude and Fugue (Bach-Kallstenius); Symphonietta for Strings and Harp, Op. 27 (Graener); Variations, Op. 8 (Saeverud); Lyric Suite (Falmgren); Con-

certino for Oboe, Clarinet and Trombone (Klami); Concerto, Op. 131, for Quartet and Orchestra (Spohr). 7.45, News in Finnish. 8.0, News in Swedish.

LANGENBERG

635 kc/s, 473 metres; 60 kW.—11.0 a.m., Orchestral Concert, conducted by Kühn: Overture, The Hermit's Bell (Maillart); Waltz, Dreams on the Ocean (Gungl); Ballet égyptien (Luigini); Norwegian Rhapsody No. 1 (Halvorsen); Pas des fleurs from Naila (Delibes); Selection from Die sieben Schwaben (Müllöcker); Waltz, Neu-Wien (Joh. Strauss). 12.15 p.m., See Frankfurt. 12.25, News and Weather. 12.35, See Stuttgart. 1.0, Meat Market Prices. 1.50, Talk for Workers. 2.10, Talk in connection with the Opening of the Ruhr Valley Museum in Schwerte (October 15th, 1933). 2.30, Exchange. 2.50, Government Announcement. 3.0, See Frankfurt. 5.0 to 5.35, See Stuttgart. 5.35, Talk: New Regulations regarding Patents and Patentes. 5.50, News. 6.0, Transmission for all German Stations, relayed from Munich. 7.0 to 9.20, See Frankfurt. 9.20, See Stuttgart. 9.30, News. 9.40, Serenade on Gramophone Records. 10.0, Old Cologne—Radio Sequence (Laurens Klesgen). 11.0, Gramophone Concert: Wilhelm Backhaus (Pianoforte): Rhapsody in B Minor, Op. 79 (Brahms); Adele Kern (Soprano): Two Arias from Don Giovanni (Mozart); Wilhelm Backhaus: Three Waltzes, Op. 39 (Brahms); Heinrich Schlusnus (Baritone): Two Songs (Hugo Wolf): (a) Der Schreckenberger, (b) Frühling über's Jahr; Georg Müller (Flute): (a) Allegro assai from the Solo per il Flauto No. 131, and (b) Amorevole from the Solo per il Flauto, No. 150 (Frederick the Great); Elizabeth Schumann (Soprano): Two Songs (Schubert): (a) Heidenröslein, (b) Lied im Grünen; Georg Kulenkampf (Violin): Romance in F (Beethoven); Ria Ginster (Soprano): Two Cradle Songs: (a) Guten Abend, gut Nacht (Brahms), (b) Maria sitzt am Rosenlag (Reger); Wilhelm Backhaus: Hungarian Dances Nos. 6 and 7 (Brahms); Heinrich Schlusnus: Adeladie (Beethoven). 12 Midnight, Close Down.

LAUSANNE.—See Radio-Suisse Romande.

LEIPZIG

769.9 kc/s, 389.6 metres; 120 kW. Relayed by Dresden, 941 kc/s, 319 metres.—2.0 p.m., Concert of Light Music by the Leipzig Concertina Orchestra: Fantasia, Stimmt ein mit hellem, hohen Klang (Hofmann); Romance, (Hermann); Humorous Variation on Was Komart dort son der Höh (Suppe); Gavotte (Latann); Dance, Trost im Leiden (Sillevedel); Loreleyklänge (Nesudaba); Styrian Dances (Lanner); Potpourri, Klänge aus dem Erzgebirge (Körcke); March, Aus dem Erzgebirge (Kanter). 3.0, Exchange and Market Prices. 3.20, Address by the President of the National Union of Artisans for German Artisans' Week, on Gramophone Records. 3.40, Readings from the German Classics: Melsiue. 4.0, Concert by the Station Chamber Orchestra, conducted by Wolfgang Daeuner: Concerto for String Orchestra and Harpsichord (Torelli); Three Pieces from the Suite No. 1 for Orchestra (Bernhard Bach); Trio Sonata No. 4 in E (Gluck); Symphony No. 3 (Philip Emmanuel Bach); Theme and Variations (Michael Haydn). 4.50, Exchange, Weather and Time. 5.0, Italian Lesson. 5.30, Popular Melodies on Gramophone Records. 5.50, Review of the Day's News. 6.0, Transmission for all German Stations, relayed from Munich. 7.0, Choral Concert, relayed from Jena. 8.0, Cabaret Thirty Years ago—Literary and Musical Sequence. In the interval at 9.0, News. 10.0, (from Dresden), Concert by the Pletzsch Marko Orchestra: Overture, Das Modell (Suppe); Waltz, Wiener Gemüt (Schrammel); In the Teahouse of a Hundred Steps (Yoshitomo); Sicilietta (Blon); Potpourri, Hellmesbergeriana (Ischpold); Waltz-Intermezzo, Ein lila Fächer (Siede); Selection from Frasquita (Lehar); Suite, A Day in Venice (Nevin); March Potpourri, Links, rechts (Eggerl); Eine kleine Liebeli (Lautenschläger). 11.30 (approx.), Close Down.

LINZ.—See Vienna.

LJUBLJANA

522 kc/s, 574.7 metres; 7 kW.—6.0, Talk. 6.30, News for Listeners Abroad. 7.0, Gramophone Records. 7.30, Opera, relayed from Belgrade. In the interval, Time and News. 10.0, Close Down.

LUXEMBOURG

352 kc/s, 1,191 metres; 200 kW.—Italian Evening. 7.0 p.m., Gramophone Music: Selection from Requiem (Verdi) by the Orchestra and Choirs of the Scala Milan. 7.50, Popular Concert by the Station Orchestra. 8.50, News in French. 9.0, Terzetto for Two Violins and Viola (Dvorak). 9.15, Talk in Italian. 9.25, Song Recital by Famous Italian Tenors, on Gramophone Records. 9.50, News in German. 10.0, Le Fontane di Roma (Respighi) on Gramophone Records. 10.20, Dance Music.

LOWO

788 kc/s, 381 metres; 16 kW.—5.45 p.m., Announcements and Gramophone Music. 6.40, Programme Announcements. 6.45, See Warsaw. 9.45, Gramophone Music. 10.30 (approx.), Close Down.

LYONS

LA DOUA, 644 kc/s, 465.8 metres; 1.5 kW.—7.40 p.m., Radio Gazette for Lyons and the South East. 8.30, Concert of Chamber Music. Conductor: Strony. Soloist: Yves Tinayre (Tenor). After the Concert, News.

MADRID

ARANJUEZ (E.A.Q.), 10,000 kc/s, 30 metres; 20 kW.—10.30 p.m., Popular Concert. In the interval at 10.45, Radio Chronicle. 11.35, Sports and Bull-fighting Notes. 11.40, Light Music. 12 Midnight till Close Down, Programme in English by the I.B.C. I.B.C. Concert: Polonaise in A flat (Chopin); Dream Tangles; La Précieuse (Kreisler); Allegretto (Bach); Hawaiian Sweetheart of Mine; Capullito de Alheli; Selection from Congress Dances; Garbo-Gitana. 12.30 a.m. (Tuesday), I.B.C. Goodnight Melody.

MADRID

EAUJ, 707 kc/s, 424.3 metres; 2kW.—7.0 p.m., Chimes, Exchange and Radio Journal. 7.20 (approx.), Baritone Song Recital: O Sole mio (Di Capua); Romance from Katuska (Sorozábal); Las hilanderas (Serrano); Russian Song from Katuska (Sorozábal); After the Programme, Dance Music. 8.15, Topical Review. 8.30 (approx.), Close Down.

MALMO.—See Stockholm.

MILAN.—See Turin.

MORAVSKA-OSTRAVA

1,137 kc/s, 263.8 metres; 11 kW.—3.0 p.m., Concert by the Station Orchestra, conducted by Musil. Overture, Sicilian Vespers (Verdi); Selection from La Boite à Joujou (Debussy); Cradle Song (Dvorak); National Dances (Prozavnik): (a) Japanese, (b) Cosack, (c) Spanish; Blues (d'Albert); Turantella (Tomasi); Woeling Waltz (Rubin); Furiant (Bayer). 3.50, See Prague. 4.5, Gramophone Music. 4.15, Talk. 4.25, Gramophone Music. 4.35, See Prague. 4.50, Milan Balear Song Recital, with the Composer at the Pianoforte. 5.15, See Prague. 5.30, German Stations—Two Legal Talks. 6.0, See Prague. 6.10, Talk: Crime and Society, relayed from Kosice, 1,022 kc/s, 293 metres. 6.25, See Brno. 7.25, Concert by a Country Band. 8.0, See Brno. 9.0, See Prague. 9.15 (approx.), Close Down.

MOSCOW

TRADES UNION, 300 kc/s, 1,000 metres; 100 kW.—10.45 a.m., Weather. 1.45 p.m., Weather. 2.0, Concert of Music by Bachmaninov, Blumenfeld and Davidov. 3.0, English Lesson. 3.30, Reading (Mark Twain), followed by Sketches and Music in the intervals. 4.0, Literary and Musical Programme for Young People. 5.30, Quartet Concert. Soloists: Amatova (Soprano), Kubatskaya (Songs), and Feinberg (Pianoforte). 6.0, News. 6.30, Programme Announcements. 8.55, Chimes from the Red Square. 9.5, Press Review. 10.0, Weather.

MOTALA.—See Stockholm.

MUHLACKER.—See Stuttgart.

MUNICH

563 kc/s, 533 metres; 60 kW. Relayed by Augsburg and Kaiserslautern, 536 kc/s, 560 metres; and Nürnberg, 1,256 kc/s, 239 metres.—3.30 p.m., Concert by the Otto Reiter Orchestra: Overture, Der Wildschütz (Lortzing); Algerian Scene (Kethely); Selection from The Bartered Bride (Smetana); Waltz, Die Schönen von Valencia (Morena); Potpourri, Selige alte Wienerzeit (Morena); Intermezzo, Indianerlager (Leinberger); March: Frischer Mut, leichtes Blut (Blon). 4.30, Talk by a Mason's Apprentice. 4.55, Humorous Programme. 5.25, Review of Books. 5.45, Time, Weather and Market Prices. 6.0, Transmission for all German Stations: Das Gansjung—a Tragicomedy (Josef Maria Lutz). 7.0 (from Nürnberg), Military Band Concert: Overture, Nakisris Hochzeit (Lincke); Waltz, Hydropathen (Gungl); Bleisoldaten (Kockert); Musikalische Täuschungen (Schreiner). 8.5, Concert of Light Music. 9.0, Austria. 9.20, Time and Weather. 10.0, Chamber Music by the Raba Quartet. 11.0 (approx.), Close Down.

NAPLES.—See Rome.

NOTODDEN.—See Oslo.

OSLO

277 kc/s, 1,083 metres; 60 kW. Relayed by Fredriksstad, 815 kc/s, 368.1 metres; Hamar, 522 kc/s, 574.7 metres; Notodden, 671 kc/s, 447.1 metres; Porsgrund, 662 kc/s, 453.2 metres; and Rjukan, 671 kc/s, 447.1 metres.—4.0 p.m., Concert by the Radio Ensemble. 5.0, Gramophone Lesson. 5.30, Concert of Norwegian Music by the Jim Johannessen Orchestra. 6.0, Announcements. Weather and News. 6.30, Election Results. In the intervals at 7.0, Time Signal, at 8.40, Weather and News, and at 9.5, Topical Talk. After the Programme, Gramophone Music.

OSTERSUND.—See Stockholm.

OCT. 16th **MONDAY** continued

PALERMO

558 kc/s, 537.6 metres; 3 kW.—7.0 p.m., Dopplavoro Notes, Tourist Talk, Agricultural Report, Report of the Royal Geographical Society and Giornale Radio. 7.20, Gramophone Music. In the interval at 7.30, Time and Announcements. 7.45, Concert of Chamber Music by a String Quartet and Scala (Pianoforte). Quartet in D Minor op. 76 No. 2 (Haydn); Pianoforte Solos: (a) Minuet (Savasta), (b) Barcarolle (Di Chiara); Sonata in G for Violin and Pianoforte (Gavazzeni); Quartet: (a) Strimpellata (Tedesco); (b) Moment musical (Schubert), (c) Scherzo (Sinigaglia). 9.10, Variety Concert. 10.0 (approx.), Close Down.

PARIS

POSTE PARISIEN, 914 kc/s, 328.2 metres; 60 kW.—7.0 p.m., Viennese Waltzes on Gramophone Records. 7.15, Le Journal Paris. 7.30, Hot Jazz on Gramophone Records. 8.0, Talk on Aviation. 8.5, Science Talk. 8.30, Song Recital. 9.15, Sponsored Concert. 10.30, News.

PARIS

RADIO PARIS, Call CFR, 174 kc/s, 1,725 metres; 75 kW.—7.30 a.m., Weather and Physical Culture. 7.45, Gramophone Music: Potpourri of Spanish Airs (Oros); Old Limousin Airs (Rouchard). 8.0, Weather and Press Review. 12 Noon, Military Band Concert on Gramophone Records. Regimental Music: Les Allobroges (Porot); Paris-Belfort (Farigoul); Le Grenadier du Caucase (Meister); Le Joyeux Trompette (Allier); March on a Theme from The Daughter of the Regiment (Donizetti-Dupont); Perthes les Hurlus (DeFrance); Indian March (Sellenick); Entr'acte from Carmen (Bizet); Ballet Music from Isoleine (Messager); Two Melodies from La Feria (Lacôme); Marche lorraine (Ganne); Invitation to the Dance (Weber); Les Préludes (Liszt); Allegro from the Roma Suite (Bizet); Spanish Caprice (Rimsky-Korsakov). In the interval at 1.0 p.m., Exchange, News and Weather, and at 1.30, Exchange. 2.0, Exchange. 3.45, Exchange and Market Prices. 6.30, Agricultural Talk. 6.50, Review of the Week's Music. 7.0, Book Review. 7.20, Gramophone Music: La Czarine (Ganne); La Forêt qui chante (Charlys); Nuit grisante (Borel-Clerc); Berceuse d'amour (Delmet); Sempre (Bianco); The Mooki (Fish). 7.45, News and Horticultural Talk. 8.0, Chamber Music and Recitations: Sonata for Cello and Pianoforte (Mozart). Recitations. Violin Solos: (a) Wiegand (Brahms), (b) Melody (Mendelssohn), (c) Rondino (Beethoven-Kreisler). Recitations. Pianoforte Solos: (a) Chromatic Fantasia (Bach), (b) Scherzo No. 4 (Chopin), (c) Mouvement (Debussy); String Quartet (Roussel). In the interval at 8.30, Commercial Prices and News, at 8.40, Review by Reboux, and at 9.15, Press Review and News.

PITTSBURGH

KDKA, 980 kc/s, 306 metres; 50 kW. Relayed by WXX on 48.86 metres and 25.27 metres.—7.30 p.m., KDKA Home Forum. 8.0 to 10.15, New York Relay. 8.0, Ark-La-Tex Day. 9.0, Betty and Bob. 9.15, Radio Guild. 10.15, KDKA Kiddies' Klub. 10.30, Singing Lady, from New York. 10.45, Orphan Annie, from New York. 11.0, Press News Reeler. 11.15, Sports, Pat Haley. 11.30, Pittsburgh Spotlights. 11.45 to 12.30 a.m. (Tuesday), New York Relay. 11.45, Lowell Thomas. 12 Midnight, Amos 'n' Andy. 12.15, Baby Rose Marie. 12.30, Richfield Country Club. 1.0 to 3.0, New York Relay. 1.0, The Nomads. 1.30, Potash and Perlmutter. 1.45, Red Davis. 2.0, Sinclair Minstrels. 2.30, Melody Moments. 3.0, Silver-toppers.

PORSGRUND.—See Oslo.

PRAGUE

614 kc/s, 488.6 metres; 120 kW.—3.0 p.m., See Moravská-Ostrava. 3.50, Programme for Children. 4.5, Gramophone Music. 4.15, Talk. 4.25, Gramophone Music. 4.35, English Lesson. 4.50, Gramophone Music. 5.5, Agricultural Talk. 5.15, Talk for Workers. 5.25, News in German. 5.30, German Transmission: Two Talks: (a) Films, (b) Gymnastics. 6.0, Time and News. 6.10, Talk: Crime and Society, relayed from Kosice, 1,022 kc/s, 293 metres. 6.25, See Brno. 7.25, See Moravská-Ostrava. 8.0, See Brno. 9.0, Time and News. 9.15, Report in German: Social Institutions in Czechoslovakia. 9.30 (approx.), Close Down.

RADIO-SUISSE ROMANDE

SOTTENS, 743 kc/s, 403 metres, 25 kW.; and Geneva, 395 kc/s, 760 metres.—6.0 to 6.15 a.m. (from Lausanne), Gymnastics. 11.28, Time Signal from Neuchâtel Observatory. 11.30, News and Weather. 11.40 (from Geneva), Gramophone Music. 12 Noon (from Geneva), Financial News. 12.10 p.m. (from Geneva), Gramophone Music. 1.0 to 2.28, Interval. 2.28, Time Signal from Neuchâtel Observatory. 3.0, See Schweizerischer Landessender. 5.0 (from Lausanne), Concert. 5.30 (from Lausanne), Programme for Children. 5.55 (from Lausanne), Italian Lesson. 6.20 (from Lausanne), Talk: Early Symptoms of Consumption. 6.45 (from Lausanne), Radio Chronicle. 6.59, Weather. 7.0 (from Lausanne), Tenor Song Recital by Leonid Kameky: Two Popular Russian Songs; Berceuse (Tcherepnin); Pimpinella (Tchaikovsky); Georgian Song (Rachmaninov); Song (Rachmaninov); Oriental Romance (Glazunov); Gopak (Mussorgsky). 7.30 (from Lausanne), Recitations. 7.50 (from Lausanne), Popular Programme by the Lausanne Station Orchestra and the Trio musette. 9.0, News and Weather. 9.10 (from Geneva), Talk: The Work of the League of Nations. 9.30 (approx.), Close Down.

REYKJAVIK

250 kc/s, 1,200 metres; 21 kW.—11.0 a.m., Weather Forecast. 1.15 p.m., Variety Programme. 4.0, Weather Forecast. 8.10, Weather Forecast. 8.20, Music and Announcements. 9.0, Light Music. 10.0, Time and News. 10.30, Popular Airs and Vocal Solos by the Radio Quartet.

RIGA

672 kc/s, 525 metres; 15 kW.—5.30 p.m., English Lesson. 6.0, Weather. 6.5, Glazunov Concert: Ballad: Symphonic Poem; Sienka Razin; Romantic Intermezzo; Mazurka; The Volga Boatman's Song; Scène de danse. 7.0, News. 7.25, Comedy (Allumans), with Music. 8.0, Weather and News. 8.10, Latvian Music. 8.30, Comedy (contd.).

RJUMAN.—See Oslo.

ROME

Call 190, 680 kc/s, 441 metres; 50 kW. Relayed by Naples, 941 kc/s, 319 metres; Milan (Vigentino), 662 kc/s, 453.2 metres from 7.45 p.m.; and 290, 11,810 kc/s, 25.4 metres from 4.15 p.m.—11.30 a.m., Gramophone Records of Opera and Variety Music. In the interval from 12.30 to 12.45 p.m., Giornale Radio and Exchange. 1.0, Time and Announcements. 3.30, Children's Radio Review. 3.55, Giornale Radio and Exchange. 4.10, Weather. 4.15, Vocal and Instrumental Concert. Olga Brogno Cesareo (Pianoforte), Juliette Azevedo (Soprano) and Leandro Forti (Baritone): Pianoforte Solos: (a) Prelude in B minor (Mendelssohn), (b) Malagueña (Albeniz). Soprano Solos: Brazilian Songs. Pianoforte Solo: Jardins sous la pluie (Debussy). Baritone Solos: (a) Aria from Il figliuol prodigo (Ponchielli), (b) Aria from Hérodiade (Massenet), (c) Aria from Carmen (Bizet). 5.40 (Naples), Shipping and Sports Notes. 5.45, Dopplavoro and Tourist Report. 6.10, Wheat Market Report. 6.20, News in Foreign Languages. 6.40, Giornale Radio. 7.0, Time and Announcements. 7.5, Song Recital by Maria Elena Cattani (Soprano). 7.30, Giornale Radio and Sports Notes. 7.45, Concert of Light Music and Variety Music, conducted by Culotta. In the interval, Talk: Love Serenades. 10.0, Giornale Radio.

SALZBURG.—See Vienna.

SCHENECTADY

WGY, 790 kc/s, 379.5 metres; 50 kW. Relayed at intervals by W2XAF on 31.48 metres and by W2XAD on 19.56 metres.—7.30 p.m., Revolving Stage, from New York. 8.0, Health Hunters—Sketch. 8.15, Soloist, from New York. 12.45 a.m. (Tuesday), Stock Reports. 1.0 till Close Down, New York Relay. 1.0, Soconyland Sketch. 1.30, John Manville. 2.0, Popular Programme. 2.30, Ship of Joy. 3.0, Contented Programme. 3.30, Musical Programme.

SCHWEIZERISCHER

LANDESSENDER

BEROMUNSTER, 653 kc/s, 459 metres; 60 kW.; Basle, 1,229 kc/s, 244.1 metres; and Bern, 1,220 kc/s, 245.9 metres.—5.50 to 6.5 a.m. (from Bern), Gymnastics. 11.0 (from Basle), Gramophone Music. 11.29, Time Signal from Neuchâtel Observatory, Weather and News. 11.40 (from Basle), Gramophone Folk Music. 12.25 p.m. (from Basle), Time, Weather and Exchange. 12.30 (approx.) to 2.30, Interval. 2.30 (from Basle), Gramophone Music. 3.0 (from Basle), Concert by the Radio Quintet. 4.0 (from Basle), Gramophone Concert. 5.0 (from Basle), Programme for Children. 5.30 (from Zürich), Programme for Women. 6.0, Time and Weather Forecast. 6.5 (from Zürich), Brass Band Music on Gramophone Records. 6.20 (from Zürich), English Lesson. 6.50 (from Zürich), Reading of Poems. 8.0, Weather and News. 8.20 (from Zürich), Organ Recital. 9.15 (approx.), Close Down.

SOTTENS.—See Radio-Suisse Romande.

STOCKHOLM

689 kc/s, 436 metres; 55 kW. Relayed by Boden, 244 kc/s, 1,229.5 metres; Göteborg, 932 kc/s, 322 metres; Hörby, 1,166 kc/s, 257 metres; Motala, 221.5 kc/s, 1,354.4 metres; Östersund, 389 kc/s, 770 metres; and Sundsvall, 554 kc/s, 542 metres.—12 Noon, Broadcast for Schools. 4.5 p.m. (from Göteborg), Accordion Music. 4.30, Reading. 4.45, Gramophone Music. 5.45, Talk on Modern German Literature. 6.15, Weather and News. 6.30, Talk: Heredity. 7.0, Pianoforte Recital by Victor Babin and Vitya Vronsky: Sonata in D (Mozart); Andante with Variations in B Flat, Op. 46 (Schumann); Sonata (Pou-

lenc). 7.50, A Visit with the Microphone. 8.10, Song Recital by Kerstin Lindberg-Torling. In the interval, Reading. 8.45, Weather and News. 9.0, Concert by the Herman Martensson Ensemble: Waltz, España (Waldteufel); Czardas No. 8 (Michiels); Selection from Martha (Flotow); Love Song (Suk); Liebestraum (Liszt); Intermezzo (Kahman); Minuet in G (Mozart); Gavotte (Gossec); Mazurka, La Czarine (Ganne); Two-Step (Roida). 10.0 (approx.), Close Down.

STRASBOURG

869 kc/s, 345 metres; 11.5 kW.—11.30 a.m., Gramophone Concert of Classical Music. 12.45 p.m., News. 1.0, Time and Exchange. 1.5, Gramophone Concert of Light Music. 2.0, Interval. 5.0, Orchestral Concert, conducted by Roskam: March, Frühlingskinder (Blankenburg); Waltz, Twilight on the Water (Squire); Overture, La petite Bohème (Hirschmann); Suite on Themes of Schubert (Raff); Barcarolle (Tchaikovsky); Three Dances (German); Selection from The Gipsy Baron (Joh. Strauss). 6.0, Literary Review. 6.15, Review of the Week. 6.30, Orchestral Concert, conducted by Maurice de Villers: Overture, Preciosa (Weber); Orchestral Suite, En camargue (Delmas); Selection from Frederica (Lehar); Romance (Svendsen); Two Spanish Dances from La vida breve (Falla). 7.30, Time and News. 7.45, Gramophone Music. 8.0, Press Review in German, Lottery Results and Announcements. 8.30, Pianoforte Recital by Lambotte: Préludes (Debussy); Pièces pittoresques (Chabrier); Caprice à cinq temps (Bordes); Prelude, Sicilienne and Aria (Castillon); Cuentas d'España (Turina); Three Pieces (Lambotte): (a) Improvptu on Walloon Themes, (b) Pochades, (c) Etude in the Form of Variations. In an interval at 9.30 (approx.), Press Review. 9.45, The Eroica Symphony (Beethoven) by the Station Orchestra, conducted by Maurice de Villers. 10.30 (approx.), Close Down.

STUTTGART

MUHLACKER, 832 kc/s, 360.5 metres; 60 kW. Relayed by Freiburg, 527 kc/s, 570 metres.—12.15 p.m., See Frankfurt. 12.25, Weather, Local News and Programme Announcements. 12.35 to 1.30, Reminiscences of Beyreuth—The Soloists, Choir and Orchestra of the Festspielhaus (on Gramophone Records). 2.15, Address by the President of the National Union of Artisans for German Artisans' Week (on Gramophone Records). 2.30, Talk: The Bavarian Forest. 3.0, See Frankfurt. 5.0, French Lesson. 5.20, Reading from the Works of Franz Heinrich Staerk. 5.35, Tales of Old Soldiers. 5.50, Time, Weather and Market Prices. 6.0, Transmission for all German Stations relayed from Munich. 7.0 to 9.0, See Frankfurt. 9.0, See Munich. 9.20, Talk: You must know... 9.30, See Frankfurt. 9.45, News. 10 to 12 Midnight, See Langenberg. 12 Midnight, Close Down.

SUNDSVALL.—See Stockholm.

TOULOUSE

779 kc/s, 385 metres; 8 kW.—6.0 p.m., News. 6.15, Hawaiian Guitar Music. 6.30, Songs from Operettas. 6.45, Argentine Music. 7.0, Popular Songs. 7.15, News. 7.30, Eine kleine Nachtmusik (Mozart), by a Symphony Orchestra. 7.45, Arias from Operas: Arrêtez, O mes frères from Samson et Delilah (Saint-Saëns); Micaëla's Aria from Carmen (Bizet); Adieu séjour fleuri, from Madame Butterfly (Puccini); Prologue to I Pagliacci (Leoncavallo). 8.0, Airs from Operettas: Overture, Les Aventures du roi Pausole (Honneger); Entr'acte from Brummel (Hahn); Selection from Le Pré aux Cleres (Hérold); Selection from The Bayadere (Kálmán). 8.15, Military Music. 8.30, Arias from Operas: Arias from The Magic Flute (Mozart); Philémon et Baucis (Gounod); Don Giovanni (Mozart); and L'Africaine (Meyerbeer). 8.45, Orchestral Music. 9.0, Le roi d'Ys—Opera (Lalo)—Concert Version. 9.30, Orchestral Music and Songs. 10.0, Accordion Solos. 10.15, News. 10.30, Concert for Listeners in Morocco. 11.0, Request Music. 11.15, Dance Music. 12 Midnight, News. 12.5 a.m. (Tuesday), Viennese Music. 12.15, Hawaiian Guitar Solos. 12.30 (approx.), Close Down.

TRIESTE

1,211 kc/s, 247.7 metres; 10 kW.—4.10 p.m. till Close Down, See Turin.

TRONDHEIM.—See Oslo.

TURIN

1,096 kc/s, 273.7 metres; 7 kW. Relayed by Milan, 905 kc/s, 331.5 metres; Genoa, 959 kc/s, 312.8 metres; and Florence, 599 kc/s, 500.8 metres.—4.10 p.m., Orchestral Concert, conducted by Tito Petralia. 5.0 to 5.5, Weather. 5.40, Giornale Radio and

Tourist Talk. 6.10, Agricultural Notes, and Wheat Market Report. 6.30, News in Foreign Languages. 6.40, Gramophone Music. 7.0, Announcements, Giornale Radio and Weather. 7.15, Sponsored Concert. 8.15, Chamber Music. 9.30, Dance Music on Gramophone Records. 10.0, Giornale Radio.

VATICAN CITY

15,120 kc/s, 19.84 metres (Morning) and 5,969 kc/s, 50.26 metres (Evening); 10 kW.—11.0 to 11.15 a.m., Religious Information in Italian. 8.0 to 8.15 p.m., Religious Information in Italian.

VIENNA

581 kc/s, 517 metres; 100 kW. Relayed by Graz, 852 kc/s, 352.1 metres; Innsbruck, 1,058 kc/s, 283 metres; Klagenfurt, 662 kc/s, 453.2 metres; Linz, 1,220 kc/s, 245.9 metres; and Salzburg, 1,373 kc/s, 218.5 metres.—10.30 a.m., Concert by the Wiener Symphoniker, conducted by Josef Holzer: March, 's gibt nur a' Wien (Holzer); Josef Lanner Overture (Fahrbachsen); Romance from the Violin Concerto No. 2 (Wieniawski); Waltz, Gold and Silver (Lehár); Potpourri of Viennese Folk Music (Kozák); Song of the Nightingale (Filipovsky). 10.55, Weather. 11.0, Weather. 11.0, Concert (contd.): Die Glocken von Prag (Fueck); Duet from The Gipsy Baron (Joh. Strauss); Waltz, Lola (Beeth); Ländler Burleske (Dörner); Viennese Song, Draussen in Mauer (Arnold); Selection from The Circus Princess (Kálmán). 12 Noon, Time and News. 12.10 p.m., Gramophone Records by Famous Artists. 2.0, Time and News. 2.20, Programme for Women. 2.30, Pianoforte Recital of Classical Music for Children. 2.55, Operetta Potpourris on Gramophone Records. 3.25, Talk for Young People. 3.50, Talk: Nietzsche as a Musician. 4.15, Aria Recital by Desider Kovacs (Baritone): Recitative and Aria from Don Sebastiano (Donizetti); Aria from La Strainera (Bellini); Aria from Linda di Chamounix (Donizetti); Aria from Maria di Rudenz (Donizetti); Aria from William Tell (Rossini); Aria from Maria di Rohan (Donizetti). 4.55, Talk: Special Exhibits at the Folklore Museum. 5.15, Book and Works of Reference in Connection with the Week's Talks. 5.20, English Lesson. 5.45, Talk: Niels Bukli, the Danish Pioneer of Gymnastics. 6.5, Concert by the Wiener Symphoniker, conducted by Josef Holzer. Soloists: Hansl and Loisl (Songs), March, An der Lan (Kopetzky); Overture, Die Fledermaus (Joh. Strauss); 'Cello Solo, Passe-Pied (Gillet); Songs: (a) O Herrgott, o Herrgott, a anzige Bitt', (b) Almräusch, Enzian und Edelweiss; Selection from Die geschiedene Frau (Fell); Scherzo (Schubert-Werner); Waltz, Heringspazier (Ziehrer); Song, Die Männertrübe, Suite, Knicks-Knacks (Tapp); Songs: (a) Heimatsstättchen (Hiron), (b) Der Summa is auss, (c) Erzherzog Johann; Marching Song, Heiss küst Anusoecka (Flemming), (b) Spanish Song, Arabella, holde Blume der Sierra (Flemming); Waltz, Auf den Bergen wohnt die Freiheit (Kozák); Potpourri, Ein lustiger Marsch durch Wien (Stilp). In the interval at 6.45, Time and News. 7.45, Topical Talk. 8.0, Concert by the Vienna Philharmonic Orchestra, conducted by Oswald Kabasta. Soloists: Mairecker (Violin) and Moravec (Viola). Don Juan, Symphonic Poem, Op. 20 (R. Strauss); Symphonie concertante in E flat for Violin and Viola (Mozart); Suite from The Fire Bird (Stravinsky). 9.10, News, Weather and Announcements. 9.25, Dance Music on Gramophone Records, followed by Announcements.

WARSAW

212.5 kc/s, 1,411 metres; 120 kW.—10.57 a.m., Time Signal and Fanfare from St. Mary's Church, Cracow. 11.5, Gramophone Records of Songs. 11.30, Radio Journal and Weather. 11.35, Symphony No. 2 (Brahms) on Gramophone Records. 12 Noon, Interval. 2.30 p.m., Economic Notes. 2.40, Tourist Report. 2.45, Anti-Gas Drill and Aviation Report. 2.55, Orchestral Concert, relayed from Lwow. 3.40, Elementary French Lesson. 3.55, Concert of Chamber Music: Trio in E flat (Mozart); Trio in E flat (Brahms). 4.50, Agricultural Notes. 5.0, Talk: A Visit to the Polish Settlements in Brazil, the Argentine and Uruguay. 5.20, Programme for Soldiers. 5.45, Miscellaneous Items. 6.5, Concert of the Works of Radz-willy Oginiski and Pomiatowski with Introductory Talk. 6.40, Programme Announcements. 6.45, Radio Journal. 7.0, Pepina—Operetta (Stolz). In the intervals, Reading and Sports Notes. 9.40, Weather and Police Notes. 9.45, Dance Music on Gramophone Records.

WILNO

533 kc/s, 563 metres; 16 kW.—6.0 p.m., Miscellaneous Items. 6.5, See Warsaw. 6.40, Programme Announcements. 6.45 till Close Down, See Warsaw.

ZAGREB

977 kc/s, 307 metres; 0.75 kW.—6.35 p.m., Book Review. 6.50, Announcements. 7.20, Introductory Talk to the following Transmission. 7.30, See Belgrade. In the intervals, News. 10.0 (approx.), Close Down.

ZURICH.—See Schweizerischer Landessender.

ATHLONE

725 kc/s, 413 metres; 60 kW. Relayed by Cork, 1,337 kc/s, 224.4 metres.—1.30 to 2.30 p.m., Time Signal, Weather Report, Stock Report, and Gramophone Concert. 6.0, Programme for Children. 6.40, News. 7.0, Talk. 7.15, Talk: The Work of the St. John's Ambulance Brigade. 7.30, Time. 7.31, Concert by Amy Ellard's Instrumental Trio. 8.0, Concert by the Culwick Choral Society, relayed from the Metropolitan Hall. 9.0, Harp Solos by Treasa Ni Chormaic. 9.15, Song Recital by Geoid O Lochlainn. 9.30 to 10.30, Programme by the I.B.C. (Ireland), Ltd. 9.30, Concert. Butterflies in the Rain (Reaves); You've got me cryin' again (Newman); No more love (Friend); Hustlin' and Bustlin' for Baby (Woods). 9.45, Concert on behalf of The People's Dispensary for Sick Animals. Arabesque (Debussy); Song, Am Meere (Schubert); Rustle of Spring (Sinding); Prelude in C Sharp Minor (Rachmaninov). 10.0, Wireless World Announcement. 10.2, Concert arranged by the International Broadcasting Company (Ireland), Ltd.: Smilin' through (Penn); Ke-sako (Chapuni); Selection from The Gipsy Princess (Kalmán); Racing Commentary; Rosa Mia (Guizar); Fairy Tales (Heykens); Spanish Sweetheart (Hargreaves); Waltz from Der Rosenkavalier (R. Strauss). 10.30, I.B.C. Good-night Melody, followed by News and Weather. 10.40, Traditional Songs. 10.50, Instrumental Trio Music. 11.0 (approx.), Close Down.

BARCELONA

EAJ1, 860 kc/s, 348.8 metres; 8 kW.—6.0 p.m., Trio Concert: Selection from Manon (Massenet); Melody (Delille); Aria (d'Ambrósio); Intermezzo from Cavalleria rusticana (Mascagni); March from The Ruins of Athens (Beethoven); Rondo (Elgar); Selection from Faust (Gounod). 7.0, Request Gramophone Music. 7.30, Exchange and Talk in Catalan. 8.0, Gramophone Music and News. 9.0, Chimes from the Cathedral, Weather, Messages to Seamen, Exchange and Market Prices. 9.5, Sponsored Programme. 9.30, Scènes napolitaines (Massenet), by the Station Orchestra. 10.0, Popular Concert by the Orfeo Atlantida. 11.0, News and Opera Music on Gramophone Records. 12 Mid-night (approx.), Close Down.

BARI

1,112 kc/s, 269.8 metres; 20 kW.—11.30 a.m., See Rome. 12 Noon, Concert from Turin. 1.0 p.m., See Rome. 3.30, Quintet Concert: Rumba paesana (d'Anzi); Autumn (Romaneli); Piccola serenata (Scassola); Medieval Suite (Amadei); Passa il torero (Bixio). 3.55 to 5.0, See Rome. 5.35, News in Albanian. 5.45 (approx.) till Close Down, See Rome.

BASLE.—See Schweizerischer Landessender.

BELGRADE

697 kc/s, 430.4 metres; 2.8 kW.—6.30 p.m., Pianoforte Recital by Mihovil Logar: Sonate quasi uno scherzo (Logar); Two Japanese Tales (Logar); Tango berceuse (Logar); Petite Suite for Pianoforte (Vukdragovic). 7.10, Dramatic Programme. 8.5, Concert by the Radio Orchestra. In the interval at 9.10, Time and News. 9.45, Gramophone Dance Music.

BERLIN

DEUTSCHLANDSENDER (Reichssender), 183.5 kc/s, 1,635 metres; 60 kW.—11.5, Gramophone Concert: Potpourri of Old Dances. 11.55, Time. 12.45 p.m., News. 1.0, Gramophone Concert of Modern Orchestral Music: Prometheus (Scriabin); Czardas and Mazurka from Coppelia (Delibes); Spanish Caprice (Rimsky-Korsakov); Petite Suite (Debussy); Bolero (Ravel). 2.0, Talk for Young People. 2.30, Weather and Exchange. 2.45, Reading from Das Kaiserbuch (Paul Ernst). 3.0, See Leipzig. 4.0, Talk for Women. 4.20, Concert of Light Music by the Bernard Dercksen Orchestra. Overture, Albin (Flotow); Waltz, Wiener Herzen (Derksen); Wogenlied (Mozart); Schwärmer Tänze (Lewalter); Rocooco und Romantik (Derksen); Selection from Barfüssele (Heuberger). 5.0, Poems. 5.5, Talk: Bayreuth under the New Regime. 5.25, Political Press Review. 5.45, Weather and Announcements. 6.0, Transmission for all German Stations, relayed from Frankfurt. 7.0, Talk: The Disarmament Conference. 7.10, Through Ireland—a Journey on Gramophone Records. 8.0, Dance Music. 9.0, News and Talk. 9.45, Weather. 10.0, Concert from Hamburg. 11.0 (approx.), Close Down.

BERLIN

FUNKSTADT, 715 kc/s, 419.5 metres; 1.5 kW.—5.0 p.m., Gramophone Concert: Rendezvous der Puppen (Gebhardt); Waltz, Was dein roter Mund im Frühling sagt (Böhmeit-Busey); Gavotte caprice (Bortkiewicz); Humoresque (Dvorak); Saxophone (Wiedoeft); Dizzy Fingers (Confrey); Waltz, Frühlingsstimmen (Joh. Strauss); Tango, Feiner Mann, was nun (Böhmeit-Busey); Foxtrot, Fensterpromenade (Mohl). 5.30, The Funkstadt informs its Listeners. . . . 5.45, Topical Talk. 6.0, Transmission for all German Stations, relayed from Frankfurt. 7.0, See Berlin (Deutschlandsender). 7.10, Lottery Announcements. 7.15, Vom braven Kasperl und dem schönen Annerl—An Old Village Tale (Clemens Brentano, arranged

for the Radio by Ernst Bringolf). 8.10, Rudolf Peterka: Memorial Programme by the Station Orchestra, conducted by Otto Frickhoeffler and the Steiner Quartet, with Gertrud Baumann (Soprano): The Last Sun-Ode by Emile Verhaeren—for Soprano, Cello, and Pianoforte; String Quartet in A Minor, Op. 9; Three Songs for Soprano and Orchestra, Op. 7; Entr'acte and Aria from Rosanna. 9.0, News. 9.20, See Hamburg. In the interval from 10.0 to 10.5, Talk: The Stage and the Cinema. 11.0 (approx.), Close Down.

BERNE.—See Schweizerischer Landessender. BEROMUNSTER.—See Schweizerischer Landessender.

BODEN.—See Stockholm.

BODO.—See Oslo.

BORDEAUX-LAFAYETTE

986 kc/s, 304 metres; 13 kW.—6.15 p.m., Radio Journal. 7.35, News and Racing Results. 7.40, Programme for Women. 7.55, Lottery Results. 8.0, Topical Talk. 8.15, News. 8.30, See Paris (Radio Paris).

BRATISLAVA

1,076 kc/s, 279 metres; 14 kW.—4.50 p.m., Cello Recital by Greta Halmova. Sicilienne (W. F. Bach); Sonata in Old Spanish Style (Cassado); Two Pieces (Schumann): (a) Träumerei, (b) Abendlied; Andante from Concerto No. 2, Op. 14 (Davidov); Spanish Dance, Op. 54, No. 1 (Popper); La fleuse, Op. 15 (Dunkler). 5.30, Gramophone Music. 5.40, Morse Lesson. 5.50, Talk for Housewives. 6.0, See Prague. 6.25, Humoresques for Pianoforte, Op. 101 (Dvorak), by Sylvia Macudzinska. 6.50, Concert by the Station Band. 7.20, See Brno. 9.0 till Close Down, See Prague. 10.0 (approx.), Close Down.

BREMEN.—See Hamburg.

BRESLAU

923 kc/s, 325 metres; 60 kW. Relayed by Gleiwitz, 1,184 kc/s, 253 metres.—12 Noon, Weather. 12.5 p.m. (approx.), Gramophone Concert: Overture, Fasching (Schmalstich); Extase (Ganne); Ballet Music from Rosamunde (Schubert); Ständchen (Richard Strauss); Dem Unendlichen (Schubert); The Sacred Hour (Ketelbey); Spatenparade (Rathke); Potpourri of Old Operetta Music. 12.45, Time and News. 1.0, Song Recital by Alfred Stöckel (Tenor): Five Songs (Schubert): (a) An die Leier, (b) Ihr Grab, (c) Erster Verlust, (d) Der Fischer, (e) Der Jüngling an der Quelle; Four Songs (Hugo Wolf): (a) Der Genesene an die Hoffnung, (b) Auf einer Wanderung, (c) Der Tambour, (d) Der Knabe und das Immelein. 1.40, Brahms Music on Gramophone Records: Tragic Overture, Op. 81; Serenade for Orchestra, Op. 11; Scherzo in D; Minuet in A. 2.0, Market Prices. 2.15, Review of Books. 2.35, Programme for Children. 3.0, Gramophone Concert: Overture, Iphigenie en Aulis (Gluck-Wagner); Air from the Suite in D (Bach); Overture, Der Freischütz (Weber); Entr'acte Music in B flat from Rosamunde (Schubert); Prelude to the First Act of Lohengrin (Wagner); Hungarian Dances Nos. 1 and 3 (Brahms). 4.20, Market Prices. 4.25 (approx.), Gramophone Concert of Modern Music: Preludes to the First and Second Acts of Palestrina (Hans Pfitzner); Entr'acte from Khovantchina (Mussorgsky); Prometheus (Scriabin); L'apprenti sorcier (Dukas). 5.0, Talk with Readings: The Poet Josef Magnus Welner and his Works. 5.15, Topical Programme. 5.35, Talk: Luther and Rome. 5.50, Market Prices. 6.0, Transmission for all German Stations, relayed from Frankfurt. 7.0, See Berlin (Deutschlandsender). 7.10 to 9.0, Programme for German Artisans' Week. 7.10, For Two Marks—Radio Play (Ernst Johannsen). 8.0, News. 8.10, Concert by a Workers' Choir: Freiheit (Schenkendorff-Groos); Aufbruch (Dohn-Brauner); Folk-Song, Des Handwerkburschen Abschied (arr. Heinrichs); Glückauf (arr. Dost); Meister und Gesell (Grübel-Zelter); Von Hause muss ich fort (arr. Scheffler); Two Folk-Songs (arr. Brauner): (a) Und in dem Schneegerbe, (b) Schneiderhochzeit; Cologne Folk-Song, Der Schiffer auf dem Rhein; Folk-Song, Jetzt kommen die lustigen Tage; Das Eisenlied (Arndt-Methfessel). 9.0, Time and News. 9.25, Political Press Review. 9.45, Light Music and Dance Music from the Stadthaus-Kaffee, Neisse. 11.30 (approx.), Close Down.

BRNO

878 kc/s, 342 metres; 35 kW.—5.25 p.m., German Transmission: News, Talk, and Agricultural Report. 6.0, See Prague. 6.25, See Moravská-Ostrava. 7.20, The Peace—Play (Aristophanes), arranged for Radio by Bedicek. 9.0, See Prague. 10.0 (approx.), Close Down.

TUESDAY
OCTOBER THE SEVENTEENTH

BRUSSELS (No. 1)

I.N.R., 590 kc/s, 509 metres; 15 kW.—12 Noon, Gramophone Music. 12.20 p.m., Pianoforte Recital by Mlle. André Lambourg. Venezia e Napoli (Liszt); Improv. No. 3 (Faure). 12.45, Gramophone Music (cont'd). 1.0, Le Journal Parlé. 1.10, Concert by the Small Station Orchestra, conducted by Leemans. 5.0, Concert by the Station Symphony Orchestra, conducted by Arthur Meulemans. Overture, Hamlet (Gade); Dance of the Fireflies, from The Damnation of Faust (Berlioz); Dance of the Sylphs, from the Damnation of Faust (Berlioz); Peer Gynt, Suite No. 2 (Grieg). 5.30, Programme for Children. 6.5, Literary Talk. 6.15, Gramophone Music. Symphonie Piece Rugby (Honegger); Saudades do Brazil (Milhaud); Prelude and Fugue in G (Bach). 6.30, Cello Recital by Rops. Largo (Dumry); Melody (Plum); Thamineh (Knosp); Romance (Risler) Poème (Rops); Berceuse (Rops). 7.0, Recital of Seventeenth and Eighteenth Century Songs by Victor Avert. 7.30, Art Notes and Talk for Women. 8.0, Concert by the Station Symphony Orchestra, conducted by Arthur Meulemans. Soloist: Léon Roy (Cello). Overture, The Mastersingers (Wagner); Cello Concerto (Lalo); Pavane pour une infante défunte (Ravel); March from The Loves for the Three Oranges (Prokofiev). 8.45, Religious Talk: The Eucharistic Congress at Kisantu. 9.0, Concert (cont'd.). Overture, The Bartered Bride (Smetana); Ballet Music from Rosamunde (Schubert); Les heures (Goeyens); In the Steppes of Central Asia (Borodin). 9.45, Cello Solos. 9.55, Christus Vincit (Liszt). 10.0, Le Journal Parlé.

BRUSSELS (No. 2)

N.I.R., 887 kc/s, 338.2 metres; 15 kW. Programme in Flemish.—12 Noon, Concert by the Small Station Orchestra, conducted by Leemans. 1.0 p.m., Journal Parlé. 1.10, Gramophone Concert. 5.0, Gramophone Concert: Foxtrot, Orange Blossom Time (Godwin); Waltz, Künstlerleben (Strauss); Your mother and mine (Godwin); One-step, New York (Padilla); Foxtrot, In the Evening (Hamley); Waltz, Love me (Mopse); Foxtrot, At Twilight (Tracy-Pinkard); Blues (Uranga); Tango, Vergib, Paloma (Brodsky); Two-Step (Hollaender); Waiting at the end of the Road (Berlin); Blues (Darantés); Waltz from Eva (Lehar); Foxtrot, O Moina (Weems). 5.45, Programme for Children. 6.30, Concert by the Small Station Orchestra, conducted by Leemans. Soloist, Wigy (Violin): Festival March (Henneberg); Minuet for String Quintet (Wynyard); Valse-Scherzo for Violin and Orchestra (Tchaikovsky); Gramophone Records: Der Neugierige (Schubert); Der Lindenbaum (Schubert); Four Lyric Pieces (Douliez): (a) Au printemps, (b) Scherzettino, (c) Intermezzo, (d) Une larme; Flemish Divertissement (Vidal); Scherzetto, Pluck and Plouck (Smissen); Tarantella, Grotta azzurra (Olivieri). 7.15, Talk. 7.30, Journal Parlé. 8.0, Musical Medley (Suls). 10.0, Journal Parlé.

BUCHAREST

761 kc/s, 394 metres; 12 kW.—4.0 p.m., Light Music and Romanian Music by the Motzot Orchestra. In the interval at 5.0, Radio Journal. 6.0, Educational Programme. 6.20, Orchestral Music on Gramophone Records. 6.40, Talk. 7.0, Song Recital by Mme. Gigartu. 7.20, Concert of Viennese Music by the Station Orchestra, conducted by Alessandresco. 8.0, Talk. 8.15, Concert (cont'd.). 8.45, Radio Journal.

BUDAPEST

545 kc/s, 550.5 metres; 18.5 kW.—Also relayed on 8.40 metres from 6.30 p.m. (approx.), till Close Down.—4.30 p.m., Gounod Concert on Gramophone Records, with Explanatory Notes. 5.10, Talk. 5.40, Military Band Concert conducted by Fricay. 6.30, The Flying Dutchman—Opera in Three Acts (Wagner), relayed from the Opera House. News in the interval. 9.0, Weather. 9.10 (approx.), Concert by the Alexander Bura Cigány Band, relayed from the Hotel Metropole. 10.0, Dance Music from the Hotel Royal.

CASSEL.—See Frankfurt.

COPENHAGEN

1,067 kc/s, 281 metres; 0.75 kW. Relayed by Kalundborg, 260 kc/s, 1,153.8 metres.—11.0 a.m., Time Signal and Chimes from the Town Hall. 11.2, Concert by the Bendix String Ensemble, relayed from the Wivex Restaurant. 1.0 p.m., Interval. 2.0, Concert by the Carl Rydals (Instrumental Ensemble). 4.0, Programme for Children. 4.30, Exchange and Fish Market Prices. 4.45, Talk on Colonies. 5.15, Elementary German Lesson. 5.45, Weather. 5.54, Announcement. 6.0, News. 6.15, Time

Signal. 6.30, Talk on Wireless. 7.0, Time Signal from the Town Hall. 7.1, Concert of French Ballet Music by the Radio Orchestra, conducted by Emil Reesen; Selection from Céphale et Procris (Grétry); Selection from Naouma (Lalo). 7.35, Recital of Old Danish Songs, by Anna Hagen. 7.50, Hekseri eller blind Alarm—Comedy in Five Acts (Ludvig Holberg). 9.15, News. 9.30, Concert of Opera Music by the Radio Orchestra, conducted by Emil Reesen: Overture, Abu Hassan (Weber); Ballet Music from Aladdin (Horneman); Selection from Hansel and Gretel (Humperdinck); Overture, La Cenerentola (Rossini); Selection from Turandot (Puccini). 10.10, Dance Music by the Jens Waryn Band, relayed from the Nimo Restaurant. In an interval at 11.0, Time Signal and Chimes from the Town Hall. 11.30 (approx.), Close Down.

CORK.—See Athlone.

DANZIG.—See Heilsberg.

DRESDEN.—See Leipzig.

FECAMP

1,328 kc/s, 225.9 metres; 10 kW.—11.0 a.m. to 12 Noon, Programme in English by the I.B.C. Happy Hour: Signature Tune; Naval Patrol (Williams); Birthday Serenade (Lincke); Post Horn Gallop (Koenig); Selection from Turkish Patrol (Michaels); Loin du bal (Gillet); General Mulcahy March (Brase); Sussex by the Sea (Ward-Higgs). Part II, Dance Music: Thank Heaven for you; Oh, Johanna; I'll show you off; I remember you from Somewhere; My Bluebird's singing the Blues; Lazybones; Wedding of the Dragonflies; Happy Ending; Signature Tune. 12 Noon, Programme in French. 4.30 to 6.0 p.m., Programme in English by the I.B.C. 4.30, The Nursery Corner. 5.0, Concert for Torquay and Exeter, on Gramophone Records: Signature Tune; The Night by the Sea; Wine, Woman and Song (Strauss); Fluttering Birds (Gemini); One Little Hair on his Head (Castling); Throw open wide your Window (Calson); A Radio Roundabout (arr. Noack); Little Tommy (Macy); A Catastrophe (Sprague); Dirt Dishin' Daisy (Klein); Selection from The Flower of Hawaii (Abraham). 5.30, Organ Recital for Plymouth and Devonport: Potted Overtures (arr. Englemann); There's an Organ playing in my Dreams (Conder); Xylophone and Organ Duet: Down South (Myddleton); The Old Spinning Wheel (Hill); Trees (Rasbach); Rain on the Roof (Ronel); Pianoforte and Organ Duet: Mariold (Mayerl); My Wishing Song (Burke); Signature Tune. 6.0, Programme in French. 10.0 (approx.) till Close Down, Programme in English by the I.B.C. 10.0, Dance Music: Signature Tune; Bells of Normandy; Sweet Dreams, Pretty Lady; Carry me back to Green, Green Pastures; Lazybones; Reflections of the Dragonflies; Adorable; Reflections in the Water; Two Buck Tim from Timbuctoo; My Gipsy Rhapsody; At the Old Pig and Whistle; It was a Night in June; My Bluebird's singing the Blues; Sundown in a Little Green Hollow; Seven Years with the Wrong Woman; Come out, Vienna; I'll show you off; Oh! Johanna; Learn to croon. 11.0, Tunes from the Talkies: Signature Tune; Sittin' in the Dark; Smilin' through (Penn); Mrs. Bartholomew (Elia); The moment I saw you; In the Moonlight (Kalmár); The Gold-Diggers' Song (Dubin); Let me give my Happiness to you (Posford); But for you (Hollander); My Lucky Day; Signature Tune. 11.30, Concert by the International Broadcasting Company (Ireland), Ltd., on Behalf of the Irish Hospitals Sweepstake Authorities: Signature Tune; Come Back to Erin; The Clatter of the Clogs (Flynn); Selection from He wanted Adventure (Walter); My Little Irish Cottage (Summers); Pan and the Wood Goblins (Rathke); Song, The Blackbird in the Apple Tree (Lubbock); The dear little Shamrock; The Child from Alsace (Lehar); Waldteufel Potpourri (arr. Finck); Signature Tune; Come back to Erin. 12.5 a.m. (Wednesday), Late News Bulletin in English. 12.10 (approx.), Club Concert for Whistable and Herne Bay Listeners: Signature Tune; The Chum Song; Lawd, you made the Night too long (Lewis); Moon over Dixie (Ellington); Arm in Arm (Zimmann); Millie (Brown); Farewell Blues (Shoebel); Let's all be Happy together (Leslie); There's a Cabin in the Pines (Hill); Sweep (Furber); A Girl like Nina (Hammerstein); Thank Heaven for you (Robin); Love Songs of the Nile (Freed); Look what I've got (Rainger); Someone stole Gabriel's Horn (Mills); Signature Tune. 1.0, Dance Music; Signature Tune; The Bells of Normandy; Hot Feet (McLugh); Drifting down the Shalimar The Gold-Digger's Song; The Windmill Waltz; A Woman should stick to her Man; I've told every little Star; Under a Blanket of Blue; I can't remember; When it's Lamp-lightin' Time in the Valley; The Language of Love; I'm one of the Lais of Valencia; Look what you've done; My Wishing Song; You did Everything for me; Stormy Weather; I shall still keep smiling along; Pop Gun; Isn't it heavenly? 2.0, I.B.C. Good-night Melody and Close Down.

FLENSBURG.—See Hamburg.

FLORENCE.—See Turin.

OCT. 17th **TUESDAY** continued

FRANKFURT

1,157 kc/s, 259.3 metres; 17 kW. Relayed by Cassel and Trier, 1,157 kc/s, 259.3 metres.—12.15 p.m., Time and News. 12.25, Local News and Weather. 12.35, See Stuttgart. 1.30, The Care of the Health of the Hitler Jugend—Programme of Speeches relayed from the Charité, Berlin. 2.30, Weather. 2.40, Time and Economic Notes. 3.0, See Leipzig. 5.0, Italian Lesson. 5.20, Medical Talk. 5.35, Talk on Economics. 5.50, News. 6.0, Transmission for all German Stations: German Wine—Radio Sequence (Wilhelm Fraenger). 7.0, See Berlin (Deutschlandsender). 7.10 to 9.0, See Langenberg. 9.0, News. 9.20, See Stuttgart. 9.30, Time and News. 9.45 to 11.0, See Stuttgart. 11.0, Von deutscher Seele—a German Cantata (Brockmeier). 12 Midnight (approx.), Close Down.

FREDRIKSSTAD.—See Oslo.

FREIBURG.—See Stuttgart.

GENOVA.—See Radio-Suisse Romande.

GENOA.—See Turin.

GLEIWITZ.—See Breslau.

GOTEBORG.—See Stockholm.

GRAZ.—See Vienna.

HAMAR.—See Oslo.

HAMBURG

806 kc/s, 372 metres; 1.5 kW. Relayed by Bremen, 1,112 kc/s, 269.8 metres; Flensburg, 1,319 kc/s, 227.4 metres; Hanover, 530 kc/s, 566 metres; and Kiel, 1,292 kc/s, 232.2 metres.—6.0 p.m., Transmission for all German Stations, relayed from Frankfurt. 7.0, See Berlin (Deutschlandsender). 7.10, Illustrated Talk: The Guild of the Mastersingers. 7.50, Choral Concert, conducted by Gerhard Gregor: Lied der Arbeit (Knorr); Two Folk Melodies: (a) Die Leineweber, (b) Loblied auf die Leineweber; Miner's Song (Armin Knab); Folk Song. Gluckauf, der Steiger kommt; Deutsche Handelshymne (Lendvai); Folk Melody, Der Schlosser und sein Gesell; Ein Kellner und ein Koch (Andreas Rauch); Folk Melody, Der Schneider. Jahrestag; Folk Melody, Handwerksburschen-Abschied; Folk Melody, Jetzt reisen wir Burschen. 8.30, Reading of Stories (Hans Freundt). 9.0, News. 9.20, Orchestral Concert, conducted by José Eibenschütz: Academic Festival Overture (Brahms); Concert Suite from Idomeneo (Mozart-Busoni); Turkish March from The Ruins of Athens (Beethoven); Elegie and Musette from the King Christian Suite No. 2 (Sibelius); Overture, Das Nachtlager von Granada (Kreutzer); Ballet Music from Coppélia (Delibes); Selection from The Merry Widow (Lehár); Waltz, Wiener Bonbons (Joh. Strauss).

HANOVER.—See Hamburg.

HEILSBURG

1,085 kc/s, 276.5 metres; 60 kW. Relayed by Danzig, 662 kc/s, 453.2 metres.—10.30 a.m., Concert by the Small Station Orchestra, conducted by Eugen Wilken. 12.5 p.m., Gramophone Concert of Music from Musical Plays and Operetta. In the intervals at 12.20 and 1.0, News. 1.30, Programme arranged by the Post Office, with Gramophone Records. 2.0, Market Prices. 2.15, Eurythmics for Children. 2.40, Talk: Reminiscences of a German Woman in Lithuania. 3.0, Concert by the Small Station Orchestra, conducted by Eugen Wilken: Miniature Suite, Karneval (Kassel); Waltz, Am schönen Rhein (Keler-Bela); Overture, Wanda (Dvorák); Selection from L'Africaine (Meyerbeer); Indian Suite No. 2 (Lüling); Potpourri, Drei Sträusse (Lindemann); Waltz, Herzade (Bayer); Overture, Isabella (Suppé); Attila-Marsch (Fucik). In the interval at 3.50, Talk: What are German Women to do for their Nation? 4.50, Review of Books on Fascism. 5.15, Market Prices. 5.25, Talk: Building Roads. 5.50, Weather. 6.0, Transmission for all German Stations, relayed from Frankfurt. 7.0, See Berlin (Deutschlandsender). 7.10, News and Weather. 7.15, Das Fest der Handwerker—Comedy (Angely). 8.20, Variety Programme. 9.0, News, followed by Political Press Review.

HILVERSUM

1,013 kc/s, 296.1 metres; 7 kW. up to 5.40 p.m. and 20 kW. from 5.40 p.m.—Programme of the Algemeene Vereeniging Radio Omroep (A.V.R.O.). 10.10 a.m., Song and Organ Recital. 10.40, Talk on Cookery: Apples and Pears. 11.10, Concert (contd.). 11.40, Concert by the Wireless Orchestra, conducted by Nico Gerharz. 1.55 to 2.10 p.m., Interval. 2.10, Concert by the Wireless Orchestra, conducted by Nico Gerharz: Scènes pittoresques (Massenet); Selection from La Bohème (Leoncavallo). 2.40, Dressmaking Lesson. 3.40, Pianoforte Recital. 4.10, Concert by a Children's Choir. 4.40, A Radio Play for Children. 5.10, Talk. 5.40, Concert of Light Music by Hans Schindler and his Orchestra. 6.10, Talk. 6.40, Song Recital by Hans Gruns: Mainacht (Brahms); Ständchen (Brahms); El Pano moruno (Falla); Jota (Falla); La berceuse du marin (Aubert); Mauvaise prière (Aubert); Adieu de l'Égypte arabe (Bizet); Pastoral (Bizet). 7.10, English Lesson. 7.40, Time and News. 7.45, Concert with Commentary. 9.10, Inquest—Radio Play (Michael Barringer). 9.55,

Concert of Light Music by Hans Schindler and his Orchestra. 10.40, News. 10.45, Gramophone Music. 10.55, Dance Music on Gramophone Records. 11.40 (approx.), Close Down.

HORBY.—See Stockholm.

HUIZEN

160 kc/s, 1,875 metres; 7 kW until 3.40 p.m. Transmitted from Kootwijk on 50 kW. from 3.40 p.m. Programme of the Catholic Radio Society (K.R.O.).—11.40 a.m., Police Notes. 11.55, Concert by the K.R.O. Orchestra. 1.25, Interval. 1.40, Programme for Women. 2.40, Concert by the Vienna Station Octet: A la bien aimée (Schmitt); Song and Tarantella (Popper); Blumengeheimnis (Neuhauser); La capriccioso (Ries); Gipsy Dance No. 1 (Nachez); Serenade (Oelschlegel); Rondo capriccioso (Mendelssohn); Waltz, Wienerblut (Strauss); Bei der Weilense in Tokay (Bor); Mein Regiment (Blankenburg); Dorfkind (Kálmán); Overture, The Gipsy Baron (Strauss); Nocturne No. 3 (Liszt); Spring Song (Mendelssohn); Selection from I Pagliacci (Leoncavallo); Fideles Wien (Komzak); In a Persian Market (Keteleby); Selection from The Flower of Hawaii (Abraham); Finale. In the intervals at 3.40, Programme by the H.I.R.O., and at 5.40, Talk. 6.20, Esperanto Lesson. 6.40, Police Notes. 6.55, Theological Talk. 7.15, Gramophone Music. In the interval at 7.25, Talk. 7.45,

LEIPZIG

769.9 kc/s, 389.6 metres; 120 kW. Relayed by Dresden, 941 kc/s, 319 metres.—12.30 p.m., Gramophone Concert. 1.15 p.m., News. 1.30, Programme to be announced. 2.15, Talk: Books we are awaiting—Segelflug (Beunelburg). 2.35, Exchange. 3.0, Concert by the Station Orchestra, conducted by Hilmar Weber: Overture, Die Feisenmühle (Reissiger); Selection from La Traviata (Verdi); Minuet from the Serenade in E Minor (Hofmann); A Feast in Aranjuez (Demerssemann) Waltz, Künstlerleben (Joh. Strauss); Selection from Paganini (Lehár). 4.10, Concert of Chamber Music: Serenade for Flute and Pianoforte (Friedrich Karl Grimm); Three Studies Op. 4 for Violin, Cello and Harp (Ernst Rudolph); Suite for Cello and Pianoforte Op. 27, No. 1 (Friedrich Karl Grimm). 4.50, Exchange, Weather and Time. 5.0, Review of Books. 5.30, Talk: Achievements of German Research. 5.50, Review of the Day's News. 6.0, Transmission for all German Stations, relayed from Frankfurt. 7.0, See Berlin (Deutschlandsender). 7.10, Mountain Strongholds: On the Kochsburg in the Mulden—a Radio Picture. 7.45, Pacherne Concert by the Dresden Philharmonic Orchestra, conducted by the Composer: Old German Dance Suite; Styrian Dances Op. 35, No. 1; Lustige Jagdmusik; Suite, German Baroque; Three Dances from Bavaria; Austrian Peasant Dances; Old Styrian

In French. 9.0, Song Recital by René Toubeau: Richard, Cœur de Lion (Grétry); A Toi (Paul Lebrun); Bonsoir (Guillemin); Extase (Radioux); Sérénade from Milenka (Blockx); Sonnet (Hubert); Chanson des heures (Rasse). 9.30, Violin Recital on Gramophone Records. 9.45, News in German. 9.55, Concert by the Radio Orchestra, conducted by Pénis: Overture, Abu Hassan (Weber); Tango des Aveux (Demaret); Dolly (d'Argèves); Liszt Potpourri (Urbach). 10.20, Dance Music on Gramophone Records.

MADRID

ARANJUEZ: EAQ; 10,000 kc/s, 30 metres; 20 kW.—10.30 p.m., Popular Concert. In the interval at 10.45, Radio Chronicle. 11.35, Spanish-American Talk. 11.45, Light Music. 12 Midnight till Close Down, Programme in English by the I.B.C. I.B.C. Concert. Mama Ines; March from the Vagabond King; Hot Feet; Bidin' my time; All through the Night; Black Eyes; Secret; Beautiful Spring. 12.30 a.m. (Wednesday), I.B.C. Goodnight Melody.

MADRID

EAJ7, 707 kc/s, 424.3 metres; 2 kW.—7.0 p.m., Chimes, Exchange, Radio Journal, and Request Gramophone Music. In the interval Talk by Joaquín España Cantos. 8.15, Topical Review. 8.30, Interval. 9.15, English Lesson. 9.30, Chimes, Time, Topical Review, and Musical Comedy Programme. 11.45, Topical Review. 12 Midnight, Chimes. 1.0 to 2.0 a.m. (Wednesday), Programme in English by the I.B.C. Dance Music. Stay out of my Dreams; My Lucky Day; Somebody stole my Gal; Drifting down the Shalimar; Hurricane Harry; What did I do?; Return of Johnnie; Sweet Savannah Sue; I raised my Hat; Madoline Solo, Faust Medley (Gounod); Twelfth-Street Rag; Roll up the Carpet; Song, Sympathy; On the other Side of Lover's Lane; Happy as the Day is Long; The Buffoon; Let's call it a Day. 2.0, I.B.C. Good-night Melody and Close Down.

MALMO.—See Stockholm.

MILAN.—See Turin.

MORAVSKA-OSTRAVA

1,137 kc/s, 263.8 metres; 11 kW.—6.25 p.m., Autumn Programme of Poetry and Music. 7.20, See Brno. 9.0, See Prague. 10.0 (approx.), Close Down.

MOSCOW

TRADES UNION, 300 kc/s, 1,000 metres; 100 kW.—10.45 a.m., Weather. 1.45 p.m., Weather Report. 2.0, The Dance in Nineteenth Century Opera—Orchestral Concert. Soloists: Muratova (Soprano), Kutcherenko (Soprano) and Menchenin (Tenor). 3.30, Literary Programme. 4.30, Programme by the Workers' Amateur Art Society. 5.30, Concert of Ballet Music, conducted by Lukin, with Gramophone Records and Sound Film Music in the intervals. 8.0, News. 8.30, Programme Announcements. 8.55, Chimes from the Red Square. 9.5, Press Review. 10.0, Weather.

MOTALA.—See Stockholm.

MUHLACKER.—See Stuttgart.

MUNICH

563 kc/s, 533 metres; 60 kW. Relayed by Augsburg and Kaiserslautern, 536 kc/s, 560 metres; and Nürnberg, 1,256 kc/s, 239 metres.—4.0 p.m., Concert conducted by Erich Kloss: Jubel-Ouverture (Ch. Bach); Lyric Suite (d'Albert); Selection from Le Bourgeois Gentilhomme (Richard Strauss); Styrian Ländler (Lanner); Faust Fantasia (Sarasate); Russian Melody, Dubnuschia (Schirmann); Chaconne (Durand); Teufelsmarsch (Suppé). 5.0, Talk on Christian Wagner, the Swabian Peasant Author. 5.20, Egon Kornauth Recital, with the Composer at the Pianoforte: Flöten-Burleske, Op. 11; Sonata for Violin, Op. 15. 5.45, Time, Weather and Market Prices. 6.0, Transmission for all German Stations relayed from Frankfurt. 7.0, Frasquita—Operetta in Three Acts (Lehár). 8.40, Talk from the Sequence: The German and the Russian Revolutions. 9.0, Time and News.

NAPLES.—See Rome.

NOTODDEN.—See Oslo.

OSLO

277 kc/s, 1,083 metres; 60 kW. Relayed by Fredriksstad, 815 kc/s, 368.1 metres; Hamar, 522 kc/s, 574.7 metres; Notodden, 671 kc/s, 447.1 metres; Porsgrund, 662 kc/s, 453.2 metres; and Rjukan, 671 kc/s, 447.1 metres.—4.0 p.m., Orchestral Concert, relayed from the Lyche Restaurant. 5.0, Programme for Housewives. 5.45, Interval. 6.0, Announcements, Weather and News. 7.0, Time Signal. 7.1, Orchestral Concert, conducted by Kramm: Hurra, die Musik kommt (Zimmer); Humorous Variations on Popular Italian Melodies (Ritzau); Waltz, Wine, Woman and Song (Strauss); Potpourri (J. Klicin); Polka from Fraenherz (Jos. Strauss); The Elves' Ball (Teilman); Piccolo and Double-Bass Duet, The Gnat and the Elephant (Kling); Perpetuum mobile (Strauss); Dance

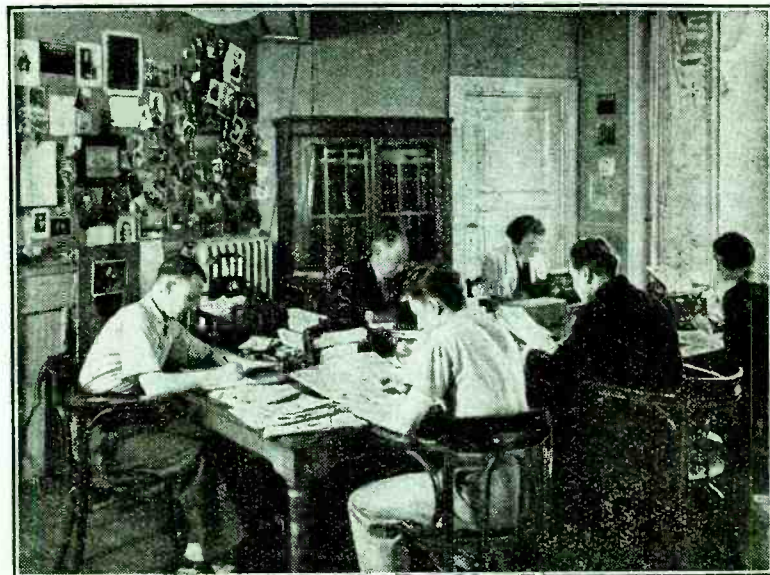

The *Journal Parlé*, one of the most popular features at Brussels No. 1, entails much careful selection from the news of the day. Here is the editorial staff at work.

White Horse Inn—Operetta in Three Acts (Stolz-Benatzky), relayed from the Stadtsschouwburg Theatre, Amsterdam. News in the intervals. 10.55, Concert of Light Music by the Vienna Station Octet. 11.40 (approx.), Close Down.

INNSBRÜCK.—See Vienna.

KALUNDBORG.—See Copenhagen.

KIEL.—See Hamburg.

KLAGENFURT.—See Vienna.

KOSICE.—See Prague.

LANGENBERG

635 kc/s, 473 metres; 60 kW.—12.15 p.m., See Frankfurt. 12.25, News. 12.35, See Stuttgart. 1.30, Talk: Highways of Germany which have made History. 1.50, Gramophone Concert: Strauss and Lanner Waltz Potpourri; Intermezzo, Träumende Glocken (Krome); Dance-Intermezzo, Sternschnuppen (Kauler); Luna Walzer (Lincke); Serenade, The Blue Pavilion (Armandola); Der Zirkus kommt (Rust). 2.10, Review of New German Books. 2.30, Exchange. 2.50, Government Announcement. 3.0, See Leipzig. 4.0, Weekly West German Review. 5.0 to 5.35, See Frankfurt. 5.35, Reading from the Works of Eduard Stucken. 5.50, Announcements. 6.0, Transmission for all German Stations relayed from Frankfurt. 7.0, See Berlin (Deutschlandsender). 7.10, Konjunktur—A Comedy of the National-Socialist Revolution of 1933 (Dietrich Loder). 8.20, Programme to be announced. 9.0, See Frankfurt. 9.20, See Stuttgart. 9.30, News, Weather and Sports Notes. 9.45 to 11.0, See Stuttgart. 11.0, See Frankfurt. 12 Midnight (approx.), Close Down.

LAUSANNE.—See Radio-Suisse Romande.

Dance; Waltz, Geschichten aus dem Ennstal; Potpourri of Alpine Songs; Die Berge hoch. 9.0, News. 9.45 (approx.), The Arts under the New Regime—a Discussion between Erwin Freytag, the Painter, and F. W. Schmoldt, the Author. 10.0, Concert Relay. 11.0 (approx.), Close Down.

LINZ.—See Vienna.

LJUBLJANA

522 kc/s, 574.7 metres; 7 kW.—6.0 p.m., French Lesson. 6.30, History Talk. 7.0, Dance Music. 7.45, Concert of Slovene National Music by a Vocal Trio, with Guitar and Accordion Accompaniment. 8.45, Time and News. 9.0, Time, News and Dance Music. 9.30 to 10.0, Programme in English by the I.B.C. 9.30, International Broadcasting Club Concert: Selection from White Horse Inn (Stolz-Benatzky); Song: Stonecracker John; Orchestra: You are my Heart's Delight (Lehár); Song: The Sergeant of the Line; Orchestra: Roses from the South (Strauss); Albumblatt; Song: Il Bacio (Arditi); Orchestra: Wine, Women and Song (Strauss). 10.0 (approx.), Close Down.

LUXEMBOURG

352 kc/s, 1,191 metres; 200 kW.—Belgian Evening. 7.0 p.m., Violin Concerto on Gramophone Records. 7.50, Talk: Children's Education. 8.0, Concert by the Radio Orchestra, conducted by Henri Pénis: Overture, Le roi l'a dit (Delibes); La jeunesse d'Hercule (Saint-Saëns); Poem, No. 2, for Cello and Orchestra (Vreulx); Dance No. 5 (Granados); Air from The Czar's Bride (Rimsky-Korsakov); The Flight of the Bumble Bee (Rimsky-Korsakov). 8.50, News

OCT. 17th **TUESDAY** continued

of the Chickens coming out of their Shells, from Pictures from an Exhibition (Mussorgsky); The Flight of the Bumble Bee (Rimsky-Korsakov); Overture, The Merry Wives of Windsor (Nicolai). 8.10, Political Review. 8.40, Weather and News. 9.0, Topical Talk. 9.15, Choral Concert. 9.45 (approx.), Close Down.

OSTERSUND.—See Stockholm.

PALERMO

558 kc/s, 537.6 metres; 3 kW.—7.0 p.m., Dopolarvo Notes, Tourist Talk, and Agricultural Report, and Giornale Radio. 7.20, Gramophone Music. In the interval at 7.30, Time and Announcements. 7.45, Il Gobbo del Califò—Opera in One Act (Casavola), followed by La grotta di Trofonio—Comic Opera in Two Acts (Salieri). Talk in the interval. 10.0, Giornale Radio.

PARIS

POSTE PARISIEN; 914 kc/s, 328.2 metres; 60 kW.—7.0 p.m., Gramophone Music. 7.15, Le Journal Parlé. 7.30, New Gramophone Records. 8.0, Talk on the Music Hall. 8.5, Film Review. 8.30, Concert of Music by Dutch Composers: Old Dances (Rontgen); Chaconna gothica (Dopper); Three Songs (Treep); Symphonic Variations for Cello and Orchestra (Mengelberg); Overture, Trois Chevaliers (Voormolen); Rhapsody, Piet Hein (Van Anrooy); Overture, Cyrano de Bergerac (Wagenaar). 10.30, News.

PARIS

RADIO PARIS, Call CFR, 174 kc/s, 1,725 metres; 75 kW.—7.30 a.m., Weather and Physical Culture. 7.45, Gramophone Records: La plus Belle (Darlay); Margotten (St. Leger); Marigold (Mayer); Prelude (Torroba). 8.0, Weather and Press Review. 12.0 Noon, Concert of Dances on Gramophone Records: Sarabande (Bach); Ochsenmuett (Haydn); Rigaudon (Rameau); Gavotte from Armida (Gluck); Passepied from La Basoche (Messager); Pavane, Mazurka and Waltz from Isolme (Messager). 12.30 p.m., Recital of French Songs by Jeanne Pierly. 1.0, Exchange, News and Weather. 1.5, Gramophone Concert: Allegro from Symphony in B Flat (Schubert); Allegretto from Symphony No. 7 (Beethoven); Andante from Symphony in E (Mozart); Adagio from the Scottish Symphony (Mendelssohn); Largo from Xerxes (Handel); Scherzo from L'Apprenti sorcier (Dukas); Minuet from Symphony in G Minor (Mozart); Vivace from Symphony in D (Haydn). In the interval at 1.30, Exchange. 2.0, Exchange. 3.45, Exchange and Market Prices. 6.30, Agricultural Talk. 6.50, Gramophone Music: Melody (Abraham); Manhattan (Allouche); Accordate nomas (Alongi). 7.0, Theatre Review. 7.20, Gramophone Records: Celui qui mou coeur aime tant (Balay); Selection from La-haut (Yvain); Montañas regaladas (Carcassone); Selection from The Bird-Fancier (Zeller); Green Eyes (Tchernoyarov); Air (Zimmermann); Overnight (Rose-Connelly). 7.45, Review of the British Press. 8.0, Gramophone Music: Three Airs from Le Couronnement de la Muse du Peuple (Charpentier). 8.15, Review by Bonnaud. 8.30, Marie-Victoria—Play in Four Acts (Maurice Maeterlinck). In the interval at 9.15, Press Review and News.

PITTSBURGH

KDKA, 980 kc/s, 306 metres; 60 kW. Relayed by **WXXK** on 48.86 metres and 25.27 metres.—7.30 p.m., KDKA Home Forum. 8.0, Programme to be announced. 8.15, Words and Music, from New York. 8.45, Congress of Clubs. 9.0, Betty and Bob, from New York. 9.15, Meredith Wilson's Orchestra, from New York. 9.30, News, Markets. 9.45, Talk, from New York. 10.0, Uncle Tom and Betty. 10.15, KDKA Kiddies' Klub. 10.30, Singing Lady, from New York. 10.45, Orphan Annie, from New York. 11.0, News, Piano Classique. 11.15, Sports, Pat Haley. 11.30, Pittsburgh Spotlights. 11.45 to 12.30 a.m. (Wednesday), New York Relay. 11.45, Lowell Thomas. 12 Midnight, Amos 'n' Andy. 12.15, Marvellous Melodies. 12.30, What Would You Do? 12.45 to 2.30, New York Relay. 12.45, Carney's Dog Stories. 1.0, Crime Clues. 1.30, Adventures in Health. 1.45, Trade and Mark. 2.0, Musical Memories. 2.30, Programme to be announced. 3.0, Pedro Via's Orchestra, from New York. 3.30, Miniature Theatre, from New York.

PORSGRUND.—See Oslo.

PRAGUE

614 kc/s, 488.6 metres; 120 kW.—3.0 p.m., Concert by the Station Orchestra, conducted by Smetacek. Dance and Introduction to Act III from Sampson (Foerster); Variations for Harp, Op. 16, on a Theme of Mozart (Prochaska); Symphonic Legend, La Forêt enchantée (d'Indy); Overture, A Night on Karlstejn, Op. 26 (Fibich). 3.35, Programme for Children. 4.15, Economic Report. 4.25, Gramophone Music. 4.35, German Lesson. 4.50, Gramophone Music. 5.5, Market Prices. 5.15, Talk for Workers. 5.25, News in German. 5.30, German Transmission: Song Recital by Irena Eisinger. 6.0, Time and News. 6.10, Talk. 6.25, See Moravská-Ostrava. 7.25, A Drama of the Sea—Radio Play. 8.25, Concert by the

Station Orchestra, conducted by Parik. Soloists: Henri Marteau and Willy Schweyda (Violin). Overture for Small Orchestra (Mysliveček); Divertissement in B Flat (Mozart). 9.0, Time and News. 9.15, Concert of Light Music. 10.0 (approx.), Close Down.

RADIO-SUISSE ROMANDE

SOTTENS, 743 kc/s, 403 metres, 25 kW.; and Geneva, 395 kc/s, 760 metres.—6.0 to 6.15 a.m. (from Lausanne), Gymnastics. 11.25, Time Signal from Neuchâtel Observatory. 11.30, News and Weather. 11.40 (from Geneva), Gramophone Music. 12 Noon (from Geneva), Financial News. 12.10 p.m. (from Geneva), Gramophone Music. 1.0 to 2.28, Interval. 2.28, Time Signal from Neuchâtel Observatory. 3.0 (from Lausanne), Concert by the Radio Lausanne Orchestra, conducted by Moser. 5.0 (from Lausanne), Programme for Women. 5.30 (from Lausanne), Literary Talk. 5.55 (from Lausanne), Theatre Notes. 6.20 (from Lausanne), Talk: The Protection of Beauty-Spots. 6.45 (from Lausanne), Radio Chronicle. 7.0 (from Lausanne), Cabaret Programme. 8.0, Eligomozur, or La Grippe politique—Comedy in Two Acts (Henri Tanner). 9.15, News and Weather. 9.20 (from Geneva), Talk: The Work of the League of Nations. 9.30 (from Lausanne), Dance Music. 10.15 (approx.), Close Down.

RJUKAN.—See Oslo.

ROME

Call **IRO;** 680 kc/s, 441 metres; 50 kW. Relayed by Naples, 941 kc/s, 319 metres; Milan (Vigentino), 662 kc/s, 453.2 metres, from 7.45 p.m.; and **2RO,** 11,810 kc/s, 25.4 metres, from 4.15 p.m.—11.30 a.m., Gramophone Concert. 12 Noon, Trio Concert from Turin. In the interval from 12.30 to 12.45 p.m., Giornale Radio and Exchange. 1.0, Time and Announcements. 3.30, Children's Radio Review. 3.55, Giornale Radio and Exchange. 4.10, Weather. 4.15 to 5.0, Orchestral Concert: Dolly (Simonetti); Notturmo romano (Mauro); Waltz, Non piangere piu (Serra); Marcia selvaggia (Florida); Liebeswalzer (Stolz); Sicilian Suite (Marinuzzi); Pifferata montanara (Culotta); Cosquillas (Furnari). 5.40 (Naples), Shipping and Sports Notes. 5.45, Morse Signals. 6.0, Tourist Report. 6.10, Wheat Market Report. 6.20, News in Foreign Languages. 6.40, Giornale Radio. 7.0, Time and Announcements. 7.15, Sponsored Music. 7.30, Sports Notes. 7.45, Variety Concert. Part I, Old Music. Soloist, Margherita Cossa (Songs); Concertino in D Minor for Mandoline quartet (Pergolesi); Four Songs (Bernardo Pasquini); Mandoline Quartet: (a) Minuet and Rondo (Bach). (b) Aria danzante (Durante); Presto from the Concerto in G Minor (Vivaldi). 8.30 (approx.), A.E.I.—Comedy in One Act (Sabatino Lopez). 9.0 (approx.), Concert (cont'd). Part II: Selection from L'Amico Fritz (Mascanigi). Part III, Gramophone Music: Overture, Coriolanus (Beethoven); Concerto in G Minor for Violin and Orchestra (Max Bruch); Intermezzo from Il carillon magico (Pick-Mangiagalli); Flower Waltz from Loreley (Catalani); Selection from Petroushka (Stravinsky). In the interval, Announcements. 10.0, Giornale Radio.

SALZBURG.—See Vienna.

SCHENECTADY

WGY, 790 kc/s, 379.5 metres; 50 kW. Relayed at intervals by **W2XAF** on 31.48 metres and by **W2XAD** on 19.56 metres.—12.45 a.m. (Wednesday), Stock Reports. 1.0 till Close Down, New York Relay. 1.0, Variety Programme. 1.30, Wayne King's Orchestra. 2.0, Ben Bernie's Orchestra. 2.30, Popular Programme. 3.0, Lives at Stake. 3.30, Popular Programme. 3.45, National Radio Forum.

SCHWEIZERISCHER LANDESENDER

BEROMUNSTER, 653 kc/s, 459 metres; 60 kW; Basle, 1,229 kc/s, 244.1 metres; and Berne, 1,220 kc/s, 245.9 metres.—5.50 to 6.5 a.m. (from Berne), Gymnastics. 11.0 (from Zürich), Light Orchestral Concert. 12.25 p.m. (from Zürich), Time, Weather and Exchange. 12.30 (approx.) to 2.30, Interval. 2.30 (from Zürich), Concert by the Small Station Orchestra, conducted by Scherbaum. 3.0 (from Lausanne), See Radio-Suisse Romande. 5.0 (from Berne), Gramophone Concert. 5.30 (from Berne), Programme to be announced. 6.0 (from Berne), Time, Weather and Talk for Schools. 6.10 (from Berne), Talk: Sunday Excursions. 6.20 (from Berne), Song Recital in Three Languages by Lotte Gassner, with Violin Obligato by Lidy Kylewer. 6.45, Concert by the Station Orchestra. 7.15 (from Berne), Variety Programme. 8.0, Weather and News. 8.10 (from Berne), Radio Play in Dialect. 9.15 (approx.), Close Down.

SOTTENS.—See Radio-Suisse Romande.

STOCKHOLM

689 kc/s, 436 metres; 55 kW. Relayed by Boden, 244 kc/s, 1,229.5 metres; Göteborg, 932 kc/s, 322 metres; Hörby, 1,166 kc/s, 257 metres; Motala, 221.5 kc/s, 1,354.4 metres; Östersund, 389 kc/s, 770 metres; and Sundsvall, 554 kc/s, 542 metres.—1.45 to 2.10 p.m., Broadcast for Schools. 4.5, Programme for Children. 4.30, Song Recital by Nils Bridell. 4.45 (from Göteborg), Light Orchestral Music: Overture, Maritana (Wallace); Waltz from Eine Ballnacht (O. Straus); Selection from Tannhäuser (Wagner); Wiegenlied (Dvorák-Kreisler); Piece (Sjöberg); March Potpourri (Rohrecht). 5.45, French Lesson. 6.15, Weather and News. 6.30, Talk: International Affairs. 7.0, Recital of Negro Spirituals by Niels Juel. 7.30, Talk. 8.0 (from Göteborg), Choral Concert, conducted by Werther Carlsson: Sanctus (Palestrina); Kyrie (Lotti); Maria welt zum Herlertum; Two Songs from the Marienlieder, (a) Ruf zur Maria, (b) Der Jäger (Eccard); Agnus Dei (Söderman); Sunday Morning (Wideen). 8.25, Reading (Goethe). 8.45, Weather and News. 9.0, Operetta Music on Gramophone Records. 10.0 (approx.), Close Down.

STRASBOURG

869 kc/s, 345 metres; 11.5 kW.—11.30 a.m., Light Music on Gramophone Records. 12 Noon, Orchestral Concert of Light Music, conducted by Roskam. 12.45 p.m., News. 1.0, Time and Exchange. 1.5, Gounod Anniversary Programme. Concert by the Station Orchestra, conducted by Maurice de Villers: Ballet Music from Cinq Mars; Chanson de printemps; Selection from Mirella; Ballet Music from Romeo and Juliet. 2.0, Interval. 4.45, Talk on the French Colonies: Guinea. 5.0, Orchestral Concert, conducted by Roskam: Marche des Sans-filistes (Pisecheck); Waltz, Dreams on the Ocean (Gungl); Serenade (Gyldmark); Albumblatt (Gyldmark); Romantic Overture (Kéler-Béla); Selection from Mignon (Thomas); Liebeslied (Hollmann); Waltz Intermezzo, Divine caresse (Bose); Caprice (Van Herck); Marche joyeuse (Guérol). 6.0, History Talk: The Empress Josephine's Childhood in Martinique. 6.15, Topical Talk. 6.30, Chopin Anniversary Programme: Rondo for Two Piano-fortes; Piano-forte Solos: Introduction and Polonaise for Cello and Piano-forte; Piano-forte Solos. 7.30, Time and News. 7.45, Gramophone Records. 8.0, Press Review in German and Lottery Results. 8.30, Programme from Paris (Eiffel Tower). After the Programme, Press Review in French.

STUTT GART

MUHLACKER, 832 kc/s, 360.5 metres; 60 kW. Relayed by Freiburg, 527 kc/s, 570 metres.—12.15 p.m., See Frankfurt. 12.25, News and Weather. 12.35, Concert by the Station Orchestra, conducted by Gustav Görlich. 1.30, Welfare Work among the Young Hitlerites—Report from the Charité, Berlin. 2.0, Military Band Concert: Overture, Im Reiche des Indra (Lincke); Waltz from Der Obersteiger (Zeller); Intermezzo (Powell); Potpourri, Von Bühne zu Bühne (Fétras); Die Puppenhochzeit (Siede); Song, Noch sind die Tage der Rosen (Baumgartner); Nylphone Solo, Serenade (Metra). 3.0, See Leipzig. 4.0, See Munich. 5.0 to 5.35, See Frankfurt. 5.35, Talk: The Fight against Crime. 5.50, Time, Weather and Market Prices. 6.0, Transmission for all German Stations, relayed from Frankfurt. 7.0, See Berlin (Deutschland-sender). 7.10 to 9.0, See Langenberg. 9.0, See Frankfurt. 9.20, Talk: You must know... 9.30, Local News. 9.45, Concert of Light Music. 10.0, Orchestral Concert, conducted by Gustav Görlich. Soloists: Hermann Lingor (Tenor) and Hans Hofele (Baritone). Florentine March (Fueick); Overture, Poet and Peasant (Suppé); Two Pieces (Löns-Blume): (a) Grün ist die Heide, (b) Der Birnbaum blüht; Meditation (Bach-Gounod); Song from the Cousin from Nowhere (Kinneke); The Blue Danube (Joh. Strauss). 11.0, See Frankfurt. 12 Midnight, Close Down.

SUNDSVALL.—See Stockholm.

TOULOUSE

779 kc/s, 385 metres; 8 kW.—6.0 p.m., News. 6.15, Popular Songs. 6.30, Music by an Argentine Orchestra. 6.45, Talk: Roquefort Cheese. 7.0, Songs from Sound Films. 7.15, News. 7.30, Ballet Music from Coppélia (Delibes). 7.45, Opera and Operatic Comique Music: Scintille diamant, from Les contes d'Hoffmann (Offenbach); Je suis l'oiseau, from Grisélidis (Massenet); Invocation of a nature, from La Damnation de Faust (Berlioz); Il fait beau voir ces hommes d'armes, from Le jongleur de Notre Dame (Massenet); Aria from The Valkyrie (Wagner); Aria from William Tell (Rossini); Aria from Tosca (Puccini); Je vais danser en votre honneur, from Carmen (Bizet). 8.15, Military Music. 8.30, Accordion Solos. 8.45, Operetta Music: Selection from Eva (Lehár); Selection from The

Dollar Princess (Fall); Viennese Operetta Revue (Robrecht). 9.0, Music Hall. 9.30, Light Music. 9.45, Songs from Sound Films. 10.0, Viennese Music. 10.15, North African News. 10.30, Concert for Listeners in Morocco. 11.0, Airs from Operettas. 11.15, Dance Music. 12 Midnight, News. 12.5 a.m. (Wednesday), Light Music. 12.15, Orchestral Pieces. 12.30 (approx.), Close Down.

TRIESTE

1,211 kc/s, 247.7 metres; 10 kW.—4.10 p.m. till Close Down, See Turin.

TRONDHEIM.—See Oslo.

TURIN

1,096 kc/s, 273.7 metres; 7 kW. Relayed by Milan, 905 kc/s, 331.5 metres; Genoa, 959 kc/s, 312.8 metres; and Florence, 599 kc/s, 500.8 metres.—4.10 p.m., Dance Music. 5.0 to 5.5, Weather. 5.40, Giornale Radio, Dopolarvo Announcements, and Gramophone Music. 6.0, Time, Report of the Royal Geographical Society, and Gramophone Music. 6.10, Agricultural Notes, and Wheat Market Prices. 6.20, News in Foreign Languages. 6.40, Gramophone Music. 7.0, Announcements, Giornale Radio, Sports Notes, and Weather. 7.25, Introductory Talk to the following Transmission. 7.30, An Operetta in Three Acts. In the intervals, Talk and Art Notes. After the Operetta, Giornale Radio.

VATICAN CITY

15,120 kc/s, 19.84 metres (Morning) and 5,969 kc/s, 50.26 metres (Evening); 10 kW.—11.0 to 11.15 a.m., Religious Information in English. 8.0 to 8.15 p.m., Religious Information in Italian.

VIENNA

581 kc/s, 517 metres; 100 kW. Relayed by Graz, 852 kc/s, 352.1 metres; Innsbruck, 1,058 kc/s, 283 metres; Klagenfurt, 662 kc/s, 453.2 metres; Linz, 1,220 kc/s, 245.9 metres; and Salzburg, 1,373 kc/s, 218.5 metres.—10.30 a.m., Music of the Austrian Alps—Gramophone Concert. 10.55, Weather. 11.0, Concert by the Wiener Symphoniker, conducted by Josef Holzer. Soloist: Jaro Schmidt (Violin). 12 Noon, Time and News. 12.10 p.m., Concert (cont'd.): Three Painful Etchings (Kételbey); Overture, Meine Jugend (Lehár); Waltz, Unsere Frauen (Fahrwach); Song, Man steigt nach! (Fall); Idyll, In der Gebirgsschenke (Lahitzky); Ich weiss ein gar heimliches Platzel (Stolz); Waltz Intermezzo, Du liebe gold'ne Meisterin (Eysler); Potpourri, Heut ist heut! (Reckenwald). 2.0, Time and News. 2.20, Talk on Photography. 2.35, Programme for Children. 3.0, Ravel Concert on Gramophone Records. 3.40, Handwork Lesson. 4.10, Chess Talk. 4.25, Johannes Evangelista Habert Concert by the Vienna Chamber Choir, conducted by Dr. Andreas Weissenböck. Soloist: Robert Günter. Introductory Talk by Franz Moissl; Das Mutterherz; Märzstürm; Wie ist doch die Erde so schön; Offertorium, Improperium; Introitus; Rorate; Communion, Ecce Virgo; Kyrie, Sanctus und Agnus Dei from the Mass, Op. 73. 5.5, Talk: Ernst Rüdiger, Count Starhemberg and his Nephew, Guidoald. 5.30, French Lesson. 5.50, Talk: Occupations and Social Standing in the Past and Present. 6.15, Time and News. 6.25, Relay from the Vienna State Opera House. News in the interval. 9.5, Announcements. 9.15, Variety Programme by the Four Funny Fellows, relayed from the Oase.

WARSAW

212.5 kc/s, 1,411 metres; 120 kW.—10.57 a.m., Time Signal and Fanfare from St. Mary's Church, Cracow. 11.5, Concert by a Man-line Orchestra, conducted by Szczeglow. 11.30, Radio Journal and Weather. 11.33, Concert (cont'd.). 12 Noon, Interval. 2.30 p.m., Economic Notes. 2.40, Talk, with Gramophone Illustrations: The Quartets of Beethoven. 3.25, News. 3.40, Answers to Correspondence. 3.55, Violin and Song Recital by Zarzycka and Peter. Violin Solos: (a) Catalonian Song (Albeniz-Dushkin), (b) Caprice viennois (Kreisler); Arias from: (a) The Girl of the Golden West (Puccini), (b) I Pagliacci (Leoncavallo), (c) Tosca (Puccini); Violin Solos: (a) Nocturne in E, Op. 27 (Chopin), (b) Scherzo Tarantella (Wieniawsky); Songs: (a) Core ingrato (Cordillo), (b) Mattinata (Leoncavallo), (c) Melody (Kratzer), (d) The Coral of your Lips (Marczewski). 4.50, Agricultural Notes. 5.0, Talk. 5.20, Light Music from the Adria Café. 6.5, Miscellaneous Items. 6.25, Topical Review. 6.40, Programme Announcements. 6.45, Radio Journal. 7.0, Concert by the Station Orchestra, conducted by Nawrot. Soloist: Mankiewicz (Songs). Spanish March (Gyldmark); Suite, Reminiscences of Cairo (Armandola); Songs; Amoroso (Bayer); Waltz from an Operetta (Jacobi); Swedish Song (Svendsen); Songs: Tarantella (Solazzi); Waltz, Flirtation (Steck); Mazurka (Namysłowsky). 8.0, Reading (Knut Hamsun). 8.15, Concert of Lithuanian Music by the Station Orchestra, conducted by Oziminski, with Introductory Talk and Gramophone Interludes. 9.15, Sports Notes. 9.25, Dance Music from the Oaza Café. In the interval at 10.0, Weather and Police Notes.

ZURICH.—See Schweizerischer Landessender.

WEDNESDAY

OCTOBER THE EIGHTEENTH

ALGIERS

824 kc/s, 364 metres; 13 kW.—7.20 p.m., Popular Songs. 7.55, News. 8.0, Time and Lottery Results. 8.40, Symphony Concert: First Symphony (Beethoven); First Suite from L'Arlesienne (Bizet). 8.45, News. 8.50, Songs on Gramophone Records. 9.0, Concert (cont.): Selection from La Redemption (Franck); 'Cello Solo, Kol Nidrei (Bruch); Selection from La vie du Poète (Charpentier); Selection from The Mastersingers (Wagner). 9.30, News. 9.35, Sketches. 9.55, News.

ATHLONE

725 kc/s, 413 metres; 60 kW. Relayed by Cork, 1,337 kc/s, 224.4 metres.—1.30 to 2.30 p.m., Time Signal, Weather Report, Stock Report, and Gramophone Concert. 6.0, Programme for Children. 6.45, News. 7.0, Gaelic Talk. 7.15, German Lesson. 7.30, Time Signal. 7.31, Concert of Folk Music by the Station Orchestra. 8.0, Folk Songs by Mme. Ritter (Soprano). 8.15, Talk: Sacred Places of Ireland. 8.35, The Station Orchestra. 8.50, Variety Items by Fay Sargent. 9.30 to 10.30, Programme by the I.B.C. (Ireland). Ltd. 9.30, Orchestral Music: Poupée valseaute (Poldini); Selection from Manon (Massenet); Song: The Floral Dance (Moss); Violin Solo: Valse bleuette (Drigo); Wireless World Announcement; Poème (Füchli); Song: The Lute Player (Aletsson); Black Eyes (Ferraris); Morgenblätter (Strauss). 10.0, Concert arranged by the International Broadcasting Company (Ireland). Ltd.: When my little Pomeranian (Little); That's all that matters (Steph); Hustlin' and Bustlin' for Baby (Woods); Racing Commentary; Then the Moon came out (Miller); Flor de Cuba; Tonight (Valero); Street of Dreams (Young). 10.30, I.B.C. Goodnight Melody, followed by News and Weather. 10.40, Dance Band Music. 11.0 (approx.), Close Down.

BARCELONA

EAJ1, 860 kc/s, 348.8 metres; 8 kW.—6.0 p.m., Trio Concert: Selection from I Paglicci (Leoncavallo); Berceuse (Rimsky-Korsakov); Romance (Schmalstich); Dance from Die Puppenfee (Bayer); Prelude in F. No. 13 (Chopin); Minuet (Meyer); Selection from The Magic Flute (Mozart). 7.0, Request Gramophone Records. 7.30, Exchange and Gramophone Music (cont.). 8.0, Gramophone Music and News. 9.0, Chimes from the Cathedral, Weather, Exchange and Market Prices. 9.5, Concert by the Station Orchestra: March (Lincke); Selection from La cautiva (Guridi); Waltz (D'Ambrosio); Dance, Serpente (Allich); Rhapsody (Saint-Saëns); Overture, Maritana (Wallace). 10.0, Relay from the Ayuntamiento.

BARI

1,112 kc/s, 269.8 metres; 20 kW.—12 Noon to 3.30 p.m., See Rome. 3.30, Programme for Children. 5.35, News in Albanian. 5.45 (approx.) till Close Down, See Rome.

BASLE.—See Schweizerischer Landessender.

BELGRADE

697 kc/s, 430.4 metres; 2.8 kW.—6.0 p.m., Concert by the Radio Orchestra. 7.0, Song Recital from Ljubljana. 9.0, Time and News and Gramophone Music. 9.35, Cigány Music from the Potrosacka Zadnaga Restaurant.

BERLIN

DEUTSCHLANDSENDER (Reichssender), 183.5 kc/s, 1,635 metres; 60 kW.—1.0 p.m., Gramophone Concert. Suite bergamasque (Debussy); Love Duet from Act I of Madame Butterfly (Puccini); Allegretto (Boccherini); Hungarian Dance, No. 5 in G Minor (Brahms); Lucia Lueti; Rhapsody in B Minor (Brahms); Sonata in A (Brahms). 2.0, Rübzahl—Play for Children. 2.30, Weather and Exchange. 2.45, Reading from Das Kaiserbuch (Paul Ernst). 3.0, See Hamburg. 4.0, Interview with Unpopular People—a Dentist, a Bailiff, a Gasman, and an Income Tax Collector. 4.25, Violin Recital by Maria Neuss. Two Pieces (Beethoven): (a) Romance in B Flat, (b) Romance in F; Perpetuum mobile (Ries); Four Pieces (Suk); (a) Quasi ballata, (b) Appassionato (c) Un poco trieste, (d) Burlesque: Introduction and poco trieste, (e) Poems. 5.5, Tarantella (Sarasate). 5.0, Poems. 5.5, Religious Address and Organ Music. 5.30, German for Germans. 5.50, Weather and News. 6.0, Transmission for all German Stations, relayed from Hamburg. 7.0, Today's Motto. 7.5, The Men of Norway—Radio Sequence from the Works of Knut Hamsun (arr. Hellmuth Unger), with Music by Paul Höffer (on Gramophone Records). 8.10, Round the World—Orchestral Concert, conducted by Eugen Sonntag, Swedish Wedding Procession (Frederiksen); Romance in F Minor (Tchaikovsky); Finnish Folk Song, Linjalähtätaat (Eckmann); Japanese Lantern Festival (Yoshitono); Chinesische Nachtigall (Niemann); Spanish Caprice, Moraima (Espinosa); Oriental March (Granados); Persian Scene, Am Zielbrunnen (Rust); Serbian Melody (Gal); Serenata Nostalgica (Marazziti); Hungarian March (Liszt); Ein Walzer aus Wien (Germann). 9.0, Weather and News. 9.45, Weather. 10.0, See Munich.

BERLIN

FUNKSTUNDE, 715 kc/s, 419.5 metres; 1.5 kW.—3.30 p.m., Orchestral Concert, relayed

from the Hans Vaterland: Selection from Madame Butterfly (Puccini); Ballgeflüster (Meyer-Helmund); Selection from The Geisha (Jones); Waltz, Wir sind heute so vergnügt (Meisel); Overture, Im Reiche des Indra (Lincke); Ich hab amal ein Räuscherl g'habt (Kapeller); Slow Foxrot, Leb wohl mein Lieb für heut (Bochmann); Waltz, Von Liebe singen alle Geigen (Kauder). 4.25, Talk: New Film Stars—Louis Graveure, Leni Spunholtz and Irmgard Willers. 4.55, Waldemar Wendland Song Recital by Else Jörn (Soprano), the Composer conducting: Der Wind; Es musste mich einer führen; Regen; Frauen; Ach, was ist die Liebe; Liebe; Ich will nicht zittern; Mädchen und Madonna; Ich aber fühle; Unter den Rüstern; Frühlingstag; Lockeliedchen. 5.5, See Berlin (Deutschlandsender). 5.40, Funkstunde informs its Listeners. 5.45, Topical Talk. 6.0, Transmission for all German Stations, relayed from Hamburg. 7.5, Recital of Folk Songs. 7.35, The Havel—a Variety Programme. 9.0, News. 9.15 (approx.), Dance Music, relayed from the Spreegarten, Treptow. In the interval at 10.0 (approx.), Report from Moabit. 11.0 (approx.), Close Down.

BERNE.—See Schweizerischer Landessender.

BERGMUNSTER.—See Schweizerischer Landessender.

BODEN.—See Stockholm.

BODO.—See Oslo.

BORDEAUX-LAFAYETTE

986 kc/s, 304 metres; 13 kW.—6.15 p.m., Radio Journal. 7.35, News. 7.40, Gramophone Music. 7.55, Lottery Results. 8.0, Agricultural Talk. 8.15, News. 8.30, Concert.

BRATISLAVA

1,076 kc/s, 279 metres; 14 kW.—4.55 p.m., Hungarian Programme. Talks: (a) Experiences of a Reporter, (b) Sports Review, followed by Recital on Two Pianofortes. 5.55, Hints for Housewives. 6.0 till Close Down. See Prague. 9.15 (approx.), Close Down.

BREMEN.—See Hamburg.

BRESLAU

923 kc/s, 325 metres; 60 kW. Relayed by Gleiwitz, 1,184 kc/s, 253 metres.—1.10 p.m. (from Gleiwitz), Adolf Scora Song Recital by Hans Kaufman (Bass), accompanied by the Composer: Und dennoch; Lied eines Auslandsdeutschen; Deutschland; Eine Kompanie Soldaten; Bergmannslied; Heimatwäandern; Oberschlesierlied. 1.40, Old Dances and Waltzes on Gramophone Records. 2.0, Agricultural Prices. 2.15, Talk: The Long Distance Telephone. 2.30, Reading (Walter Schatz). 2.50, Talk on Silesia. 3.10, Concert by a Nazi Band. Soloist: Alfons Kabitschke ('Cello); March, Unsere Marine (Friedemann); 'Cello Concerto (Klughardt); Gavotte, Pasteur amoureux (Aletter); Die Spieldose (Manfred); Fantasia on Themes from Verdi's Opera, La Traviata (Schreiner); Waltz, Lebensgeister (Manfred); March Potpourri, Deutschlands Erwachen (Kochmann). 4.15, Wireless Talk: The New German Wireless Receiver in Upper Silesia. 4.35, Concert of German Students' Songs by the Upper Silesian Quartet. 5.5, String Quartet in A minor, Op. 132 (Beethoven), by the Klinger Quartet. 5.50, Meat Market Prices. 6.0, Transmission for all German Stations, relayed from Hamburg. 7.0, News. 7.10, Request Concert by the Station Orchestra, conducted by Topitz: Prelude in C (Bach); Opening Choral from the Cantata, Es erhuh sich ein Streit (Bach); Motet for Eight Voices (Marx); Hymn for Male Voice Choir, Wind Instruments, and Organ: Der Retter ist nicht weit (Graener); Cantata for Eight-voice Choir and Orchestra: Nun ist das Heil und die Kraft (Bach). 9.0, Austria. 9.20, Time and News. 9.45, Dance Music relayed from Linden-Diele, Malmitz. 11.30 (approx.), Close Down.

BRNO

878 kc/s, 342 metres; 35 kW.—5.25 p.m., German Transmission: News and Talk on German Authors. 6.0, See Prague. 9.30 (approx.), Close Down.

BRUSSELS (No. 1)

I.N.R., 590 kc/s, 503 metres; 15 kW.—12 Noon, Concert by the Max Alexys Orchestra. 1.0 p.m., Le Journal Parlé. 1.10, Concert by the Small Station Orchestra, conducted by Leemans: Overture, Mademoiselle Daetylo (Raimann); Intermezzo from Le Pavillon d'Armide (Tcherepini); Waltz from The Rose of Stamboul (Fall); Selection from Miss Decima (Audran); Violin Solo: Caprice viennois (Kreisler); Piccolo Solo: Le Merle blanc (Damaré); Suite, Mascarade (Lacôme). 5.0, Concert by the Radio Orchestra,

conducted by Charles Walpot: Rhapsody in B (Hartung); Hungarian Rhapsody No. 2 (Liszt); Rapsodie Duhomienne (de Boeck); Slav Rhapsody No. 2 (Friedemann); Chinese Rhapsody (Gabriel Marie); España (Chabrier). 6.0, Gramophone Music. 6.15, Le coeur et le brownling—Play in Three Acts (Rodo-Mahert). 7.0, Song Recital by Mme. Van Houdt-Volekaert: Serenade de l'amant jaloux (Grétry); Air d'Isaac (Monquet); Le bonheur est chose légère (Saint-Saëns); Berceuse (Gretchaninov). 7.15, Extracts from the Sonata in D, Op. 12, No. 1 (Beethoven) on Gramophone Records. 7.30, Talk on Hygiene. 8.0, Concert by the Station Symphony Orchestra, conducted by Jean Kumps. Soloist: Henri Koel (Violin). Overture, Gwendoline (Chabrier); Violin Concerto in D (Beethoven); Carnival de Paris (Sveinssen). 8.30, Un confident—Comedy in One Act (Max Beauville). 9.0, Concert (cont.): Overture, Figaro (Mozart); Nocturne (Brenta); Quartet for Horns (de Maleingrau); Andante and Scherzo from the Symphony in D (Absil); Violin Solos: (a) Havanaise (Saint-Saëns); (b) Aria (Bach); Nursery Suite (Ingelbrecht); Military March No. 3 (Schubert). 10.0, Le Journal Parlé.

BRUSSELS (No. 2)

N.I.R., 887 kc/s, 338.2 metres; 15 kW. Programme in Flemish.—12 Noon, Concert by the Small Station Orchestra, conducted by Leemans. Soloist: berissen ('Cello). Overture, Tancredi (Rossini); Russian Rhapsody, Svetlana (Weksler); Bells across the Meadows (Kettelbey); Selection from The Pearl Fishers (Bizet); Tarantella for 'Cello (Popper); Waltz, Die Nachtschwärmer (Zihrer); Noveletta (Caludi); The Mill in the Black Forest (Eilenberg); March (Berry). 1.0 p.m., Journal Parlé. 1.10, Concert by Max Alexys and his Orchestra. 5.0, Concert, relayed from the Century Hotel, Antwerp. 6.0, Gramophone Records: Two Fairy Eyes, from The Circus Princess (Kálmán); Volga Song from The Czarevitch (Lelár); Selmsuchtstraum (Tate-Roonthal); Melody from Paganini (Lelár); Song from Frasquita (Lelár). 6.15, Talk: Popular Irish Songs. 6.30, Concert by the Small Station Orchestra, conducted by Leemans: Marche jubilaire (De Boeck); Suite campestre (Amadei); Reverie (La Gye); Ballet Scene (de Taeye); Selection from Piccolino (Guiraud); Gavotte for Strings, Flute and Clarinet (Wigy); Tarantella for Pianoforte (Wigy); Petite suite miniature (Dulois); Descriptive Piece (Caludi). 7.15, Protestant Address. 7.30, Journal Parlé. 8.0, Concert by the Radio Orchestra, conducted by Walpot. Soloists: Mme. Bruylants and M. Vercaem (Songs) and Gras (Pianoforte). March, The Washington Post (Sonsa); Overture, Poet and Peasant (Suppé); Songs with Orchestral Accompaniment: Prelude to and Intermezzo from Cavalleria rusticana (Mascani); Songs; Potpourri of Cigány Music (Meyer-Helmund). 8.45, Reading. 9.0, Concert (cont.): Egyptian March (Strauss); Rhapsody in Blue for Pianoforte and Orchestra (Gershwin); Songs: Two Flemish Dances (Blockx); Songs with Orchestral Accompaniment: Neapolitan Dances (Desormes); Vocal Duet; Gallop, Feu d'artifice (Demaels). 10.0, Journal Parlé.

BUCHAREST

761 kc/s, 394 metres; 12 kW.—4.0 p.m., Concert by the Station Orchestra: March (Fenic); Waltz (Waldteufel); Overture, The Force of Destiny (Verdi); Selection from Don Giovanni (Mozart); Schubert Potpourri (Urbach). 5.0, Radio Journal. 5.10, Song and Pianoforte Recital. 5.30, Concert (cont.): Musical Pleasantries (William). 6.0, Educational Programme. 6.20, Orchestral Music on Gramophone Records. 6.40, Talk. 7.0, Violin Recital by Flomen. 7.30, Talk. 7.45, Songs by Mme. Nina Aureliana. 8.15, 'Cello Recital by Draghici. 9.0, Light Music relayed from a Restaurant.

BUDAPEST

545 kc/s, 550.5 metres; 18.5 kW.—Also relayed on 840 metres from 6.40 p.m. till Close Down.—3.0 p.m., Concert by the Lajos Kiss Cigány Band. 4.15, Talk. 4.45, Concert by Lesoncz Oscar Schweizer and his Orchestra. 6.0, Reading. 6.40, An Operetta. 8.40, News. 9.0, Song Recital by Tilor, Vitez. Aria from The Magic Flute (Mozart); In Grab from The Mastersingers (Wagner); Am Meerstrand (Schubert); Aria from La Bohème (Puccini); Song (Schumann). 9.30, Concert by the Alexander Farkas Cigány Band from the Café Bodo. Soloist: Dani.

CASSEL.—See Frankfurt.

COPENHAGEN

1,067 kc/s, 281 metres; 0.75 kW. Relayed by Kalundborg, 260 kc/s, 1,153.8 metres.—

11.0 a.m., Time Signal and Chimes from the Town Hall. 11.2, Concert by the Leonard Gyldmark String Ensemble, relayed from the Bellevue Strandhotel. 1.0 p.m., Interval. 2.0, Concert of Variety Music on Gramophone Records. 2.30, Concert by the Mogens Hansen Instrumental Ensemble: Overture, Salvator Rosa (Gomez); Selection from The Rose of Florida (Fall); Spanish Waltz, Saungo (Corbin); Piece (Kronberger and Marriot); Eine Frühlingsmärennacht (Krome); Barcarola appassionata (Murzilli); An soir de la vie (Pesse); Liebestraum (Blon); Madrigalette (Bullerian); Serenade (Cajani); Waltz Fantasia (Waldteufel); Sérénade badine (Gabriel-Marie); Sylphiden (Lincke); Traversée heureuse (Fl. Schmitt); Piedmontese Serenade (Leopold); March, Sie kommen (Lincke). In the interval at 3.15 (approx.), Talk for Children. 4.30, Exchange and Fish Market Prices. 4.45, Talk. 5.15, French Lesson. 5.45, Weather. 5.54, Announcements. 6.0, News. 6.30, Concert from the Town Hall. 7.0, Time Signal from the Town Hall. 7.1, Serenade in E (Dvorak), by the Radio String Orchestra, conducted by Lanny Gröndahl. 7.25, Talk. 7.55, Music from Holberg's Time—Recital by Erik Thomsen (Flute), Leo Hansen (Violin), and Folmer Jensen (Harpischord); Movement from the Sonata for Flute and Harpischord (Freit-holt); Movement from a Harpischord Sonata (Scheibe); Folia con variazioni for Violin and Harpischord (Corelli). 8.20, Talk with Readings: Holberg's Epistles. 9.0, News. 9.15, Concert of Danish Music, by the Radio Orchestra, conducted by Lanny Gröndahl: Overture, Erik Ejegod (Kunzen); Four Dances (Thielø, arr. Gröndahl); Overture, Et Eventyr i Rosenborg Have (Weyse); Morgenstemning, from the Music to Hakon Jarl (Hartmann); Prelude to Syssoverdag (Hartmann); Two Dances from the Music by Aladdin (Nielsen). 10.0, Dance Music by the Richard Johansen Band, relayed from the Lealberg Restaurant. In an interval at 11.0, Time Signal and Chimes from the Town Hall. 11.30 (approx.), Close Down.

CORK.—See Athlone.

DANZIG.—See Heitsberg.

DRESDEN.—See Leipzig.

FECAMP

1,328 kc/s, 225.9 metres; 10 kW.—11.0 a.m. to 12 Noon, Programme in English by the I.B.C. Happy Hour; Part I, Request Programme: Signature Tune; On the Quarter-Deck (Alford); Fiddlin' Jo' (Kavanaugh); Love's Old Sweet Song (Molloy); Presto agitato—Moonlight Sonata (Molloy); Drinking Song from the Rose of Persia (Sullivan); Smilin' through (Penn); Lounderyery Air (arr. Grainger); The Birth of the Blues (Heuderson). Part II, Dance Music: At the Old Pig and Whistle; A Girl like Nina; Twelfth Street Rag; Since Maggie became Margaret; My Gipsy Rhapsody; I raised my Hat; I cover the Waterfront; Signature Tune. 12 Noon, Programme in French. 4.30 to 6.30 p.m., Programme in English by the I.B.C. 4.30, The Nursery Corner. 5.0, Quintet Concert for the Isle of Wight: Signature Tune: The Night by the Sea; Gavotte from Mignon (Thomas); Song, Reflections in the Water (Leeb); Ma Curly-headed Baby (Clutsam); Orientale (Glazounov); The Song of the Nightingale (Albouth); Song, Fairy Tales of Ireland (Coates); Butterflies in the Rain (Myers); Cherry Ripe (Traditional). 5.30, Concert for Portsmouth and Southsea. Music Hall and Musical Comedy Memories: Selection from The Quaker Girl (Monckton); My Old Dutch (Chevalier); Songs made Famous by Harry Champion; Choral Selection from La Poupée (Audran); Gaiety Echoes; The Wink of the Old Glad Eye; After the Ball (Harris); Two Little Girls in Blue (Graham); Selection from Floradora (Leslie Stuart); Signature Tune. 6.0, Programme in French. 10.0 (approx.). Dance Music: Signature Tune; Bells of Normandy; Have you had a Good Day To-day?; The Shadow Waltz; Learn to Croon; Erie Moon; Dancing Butterfly; It's Sunday down in Caroline; Lover Waltz; Isn't it Heavenly?; My Lucky Day; Avalon; Bugle Call Rag; Oh! Johanna; Shutdown in a Little Green Hollow; Lazybones; I sigh for you, Rio Rita; Sweet Dreams, Pretty Lady. 11.0, Talkie Time: Signature Tune; Sittin' in the Dark; You are too Beautiful; There'll still be Love; Heaven will protect an Honest Girl; Hits from Forty-Second Street; Adorable; There's Magic in the Air; Selection from Puttin' on the Ritz; I got Rhythm; Signature Tune. 11.30, A Gramophone Concert: Pictorial Records: When my Little Pomeranian (Little); My Wishing Song (Burke); Old Spotted Cow (Krome); Spanish Sweetheart (Evans); Heaven will protect an Honest Girl (Weston); Pianoforte Solo: Selection from A Bedtime Story; Song of the Tramp (Sievier); I lay me down to sleep (Wrubel). 12.5 a.m. (Thursday), Late News Bulletin in English. 12.10 (approx.), Club Concert for Rochester Listeners: Signature Tune; Mad Moments (Hopkins); The World is so Small (Nesbitt); Play, Fiddle, play (Lawrence); Jack-in-the-Box (Shand); The Japanese Sandman (Whiting); Signature Tune; I'll show you off (Hammerstein); Down in the Valley (Harrington); Reflections in the Water (Webster); My Gal Sal (Dresser); Happy Ending (Parr-Davies);

OCT. 18th **WEDNESDAY** continued

What a Lady Josephine must have been (Pola); I raised my Hat (Franz); P.C. 123—The Policeman's Song (Butler). 1.0, Dance Music: Signature Tune; The Bells of Normandy; Under a Blanket of Blue; Twelfth Street Rag; Sweetheart Darlin'; Peter, Peter; Down the Old Ox Road; Stay out of my Dreams; I always keep my Girl out Late; Love is the Thing; At the Old Pig and Whistle; Nobody's Sweetheart; Love Songs of the Nile; From me to you; I wish I had Wings; Someone stole Gabriel's Horn; Spanish Eyes; Let's call it a Day. 2.0, I.B.C. Good-night Melody and Close Down.

FLENSBURG.—See Hamburg.

FLORENCE.—See Turin.

FRANKFURT

1,157 kc/s, 259.3 metres; 17 kW. Relayed by Gassel and Trier, 1,157 kc/s, 259.3 metres.—12.15 p.m., Time and News. 12.25, Local News and Weather. 12.35, Concert from Stuttgart. 1.30, Finland, the Land of a Thousand Lakes—Programme for Young People. 2.30, Weather Forecast. 2.40, Time and Market Prices. 3.0, Concert from Stuttgart. 5.0 to 5.35, See Langenberg. 5.35, Talk: The American and German Youth Movement. 5.50, News. 6.0, Transmission for all German Stations, relayed from Hamburg. 7.0, Topical Talk. 7.10, Variety Programme. 9.0, News. 9.20, See Stuttgart. 9.30, Time and News. 9.45, Light Music. 10.0, Serenade. 11.0, See Stuttgart. 12 Midnight, Close Down.

FREDRIKSSTAD.—See Oslo.

FREIBURG.—See Stuttgart.

GENEVA.—See Radio-Suisse Romande.

GENOA.—See Turin.

GLEIWITZ.—See Breslau.

GOTEBORG.—See Stockholm.

GRAZ.—See Vienna.

HAMAR.—See Oslo.

HAMBURG

806 kc/s, 372 metres; 1.5 kW. Relayed by Bremen, 1,112 kc/s, 269.8 metres; Flensburg, 1,319 kc/s, 227.4 metres; Hanover, 530 kc/s, 566 metres; and Kiel, 1,292 kc/s, 232.2 metres.—3.0 p.m., Concert by the Hamburg Philharmonic Orchestra, conducted by Secker: Overture, Am Rhein (Kaun); Mephisto-Walzer (Liszt); Irish Rhapsody (Stanford); Valse triste (Sibelius); Extracts from The Kingdom of Pan (Graener); Overture, In Autumn (Grieg). 4.0 (from Kiel), Reading of Animal Stories (Ehrke). 4.30, Topical Talk. 5.3, Concert of Dances by the Small Station Orchestra, conducted by Maasz: Spanish March (Gyldmark); Russian Dance No. 2 (Bullerian); Slav Dance No. 12 (Dvorak); Hungarian March (Schubert); Swedish Dance (Aulin); German Dances (Reger); Three Dances from Bavaria (Pacherneuz); Radezky March (Jos. Strauss). 5.40, Frankfurt Exchange and Hamburg Market Prices. 5.50, Weather. 6.0 (from Bremen), Transmission for all German Stations: Concert from Bremen Cathedral: The Symphony Orchestra, the Cathedral Choir, and the Bremen Teachers' Choral Society; Soloist, Kate von Tricht (Organist): Prelude in C for Organ (Bach); First Choral from the Cantata, Es erhub sich ein Streit (Bach); Motet for Eight Voices, Werklente sind wir, Op. 6 (Karl Matx); Male Voice Choir: Hymn, Der Retter ist nicht weit, Op. 95 (Graener); Michaelmas Cantata for Eight Voices and Orchestra, Nun ist das Heil und die Kraft (Bach). 7.0, Die große Not—Dialect Play in Five Scenes (Möhning). 8.20, Gramophone Music. 9.0, Time, Weather and News. 9.20 (from Bremen), Cello Recital by Schulz-Fürstenberg: Variations on a Theme from Mozart's Magic Flute (Beethoven); Andante (Schulz-Fürstenberg); Mutter (Zschornich); Guitar (Moszkowsky). 9.50, From Lanner to Lilling—Concert by the Small Station Orchestra, conducted by Secker; Soloist, Gustav Zippel (Vibraphone); March, Schneidige Truppe (Lehnhardt); Waltz, Die Pesther (Lanner); Dream Pictures (Lumbye); Overture, Lysistrata (Lincke); Indian Suite (Lilling); Vibraphone Solo: Romance (Löhn); Potpourri, The Three Strausses (Lindemann); Overture, Wiener Frauen (Lehár).

HANOVER.—See Hamburg.

HEILSBURG

1,085 kc/s, 276.5 metres; 60 kW. Relayed by Danzig, 662 kc/s, 453.2 metres.—12.5 p.m., Gramophone Concert of Serenades. In the Intervals at 12.20 and 1.0, News. 1.30, Programme arranged by the Post Office with Gramophone Records. 2.0, Agricultural Prices and Exchange. 2.20, Hints for the Housewife. 2.30, Programme for Children. 3.0, Concert by the Small Station Orchestra, conducted by Wilcken: Prelude to The Cricket on the Hearth (Gohlmart); Suite der Freude (Scheinpflug); Fantasia, Old Russia (Leuschner); Waltz from Die Puppenfee (Bayer); Selection from The Hermit's Bell (Mailart); Overture, Die Irrfahrt ins Glück (Suppé); Selection from Der Feldprediger (Müllcker); Waltz from Der Rastelbinder (Lehár); Reminiscences of Verdi (Worch). 4.35, Programme in Memory of

the Battle of Leipzig, October 16-19, 1813. 4.50, Talk for Parents. 5.15, Agricultural Prices. 5.25, Song Recital by Paul-peter Rafalski: Der König in Thule (Zelter); Im Rolandsbogen (Mania); Im tiefen Keller (Fischer); Die Drei Reiche der Natur (Berger); Der Sang ist verschollen (Sommer); Der Schlesische Zecher und der Teufel (Reissiger); Die bange Nacht ist nun herum (Lyra); Wohlaufl Kameraden (Zalm). 5.50, Weather. 6.0, Transmission for all German Stations, relayed from Hamburg. 7.0, News and Weather. 7.10, Dance Music by the Small Station Orchestra, conducted by Wilcken and the Börschel Dance Band. 9.0, News, Weather, and Sports Notes, followed by Concert Relay. 11.0 approx., Close Down.

HILVERSUM

1,013 kc/s, 296.1 metres; 7 kW. up to 5.40 p.m., and 20 kW. (from 5.40 p.m.).—11.40 a.m. till Close Down, Programme of the Workers' Radio Society (V.A.R.A.). 11.40, Concert by the Small Station Orchestra, conducted by de Groot. 1.40 p.m., Interval. 1.55, Orchestral Concert. 2.40, Programme for Children. 5.10, Concert by the Station Orchestra, conducted by de Groot: Overture, The Merry Wives of Windsor (Nicola); Alt-Wiener Reigen (Strauss); Moorish Serenade (Chapi); Selection from Tiedland (d'Albert); Spanish Dances (Moszkovsky); Ons orkest (de Groot); Xylophone Solo (Krüger); Caprice viennois (Kreisler); Le cygne (Saint-Saëns); Polonaise (Schreiner); Gavotte (Popper); The Music Box (Lindsay); Carnival in Venice; Minuet (Bizet); Polka (Konst); Selection from Martha (Flotow); La tourterelle (Demaré); Grossmütterchen (Lange); The Clock is Playing (Blaauw); Melody (Rubinstein); Idylle écossaise (Saint-Saëns); Air from Henry VIII (Saint-Saëns); Humoresque (de Groot); Melody (Mayer); Russian Dance; Get a Load of This (Stillwell); Twelfth Street Rag (Wiedoeff); The Toy-maker's Dream (Golden); Say it with Music (Berlin). 6.40, Talk. 7.0, Concert by the V.A.R.A. Orchestra, conducted by de Groot: March, Friendship (Sousa); Tesoro mio (Becucci); The Mill in the Black Forest (Eilenberg); Selection from The Tales of Hoffmann (Offenbach); Im Spielwarenladen (Jessel); Valse poudrée (Popy); The Gladiators' Farewell (Blankenburg). 7.35, S.O.S. Announcements. 7.40, News. 7.50, Orchestral Concert (cont'd.): Overture, Banditenstrieche (Suppé); Waltz, Herbstrosen (Strauss); Ballet Music from Ritter Pasman (Joh. Strauss). 8.20, Concert by the Bel Canto Male Voice Quartet. In an interval at 8.40, Radio Play (Heyermans van Duin). 11.0, Organ Recital by Jong. 11.20, Gramophone Music. 11.40 (approx.), Close Down.

HORBY.—See Stockholm.

HUIZEN

160 kc/s, 1,875 metres, 7 kW. (until 3.40 p.m.). Transmitted from Kootwijk on 50 kW. from 3.40 p.m.—Programme of the Christian Radio Society (N.C.R.V.). 12.10 p.m., Concert by the Van der Horst Ensemble: Overture, Pique Dame (Suppé); Waltz, Wiener Bürger (Ziehrer); Selection from Werther (Massenet); Selection from Piccolino (Giraud); Gramophone Music: Overture, Masaniello (Auber); L'étoile du nord (Waldteufel); Danse macabre (Saint-Saëns); Potpourri, A. B. C. (Komzak). 1.40, Programme for Children. 2.25, Religious Address. 2.55, Concert by the Delft Trio: Trio, Op. 70, No. 1 (Beethoven). 3.25, Interval. 3.40, Concert (cont'd.): Hebrew Song (Castellnuovo-Tedesco); Andantino (Martini-Kreisler); Andalusian Romance (Sarasate); Gramophone Music: Trio, Op. 38 (Gretchaninov). 4.40, Programme for Children. 5.40, Agricultural Talk. 6.10, Programme to be announced. 6.40, Police Report. 6.55, Ecclesiastical Notes. 7.10, Talk on Russia: 7.40, Concert arranged by the Missionary Society at Oegstgeest: Soloists: Smit Duyzentkunst (Baritone) and Muddle (Organist); Toccata and Fugue in D Minor (Bach); Choir: Gott sei mir gnädig (Mendelssohn); Chorus from Elijah (Mendelssohn); Address; Psalm 103; Address; Bussied (Beethoven); Grand Gloria (Bortniansky); Andante con moto (Pomper); Missionary Hymn (Zwart); Improvisation (Muddle). 9.10, News. 9.20, The Messiah—Oratorio (Händel) by the British Broadcasting Company's Choir and Orchestra, conducted by Sir Thomas Beecham (on Gramophone Records). 11.10 (approx.), Close Down.

INNSBRUCK.—See Vienna.

KALUNDBORG.—See Copenhagen.

KIEL.—See Hamburg.

KLAGENFURT.—See Vienna.

KOSICE.—See Prague.

LANGENBERG

635 kc/s, 473 metres; 60 kW.—10.0 a.m., Broadcast for Schools: German Men of

Letters—Kleist. 10.25, Sponsored Programme with Gramophone Music. 10.55, Weather. 11.0, Dances of the Nations—Concert by the Station Orchestra, conducted by Buschkötter: German Dances (Schubert); Hungarian Dances (Brahms); Spanish Dance (Granados); Slav Dances (Dvorak); Norwegian Dance (Grieg); Russian Dance (Napravnik); Old Dutch Dance (Siep). 12.15 p.m., See Frankfurt. 12.25, News and Weather. 12.35, See Stuttgart. 1.30, See Frankfurt. 2.30, Economic Notes. 2.50, Political Announcement. 3.0, See Stuttgart. 5.0, German for Germans. 5.20, Talk: The Racial Question. 5.35, Talk: The Latest Developments in Science and Technology. 5.50, Announcements. 6.0, Transmission for all German Stations, relayed from Hamburg. 7.0 to 9.20, See Frankfurt. 9.20, See Stuttgart. 9.30, News, Weather and Sports Notes. 9.45 to 11.0, See Frankfurt. 11.0, See Stuttgart. 12 Midnight, Close Down.

LAUSANNE.—See Radio-Suisse Romande.

LEIPZIG

769.9 kc/s, 389.6 metres; 120 kW. Relayed by Dresden, 941 kc/s, 319 metres.—11.0, Concert by the Emde Orchestra: March (Kochmann); Prelude and Siciliana from Cavalleria rusticana (Mascagni); Ibbelentänze (Eilenberg); Slow Waltz, The First Letter (Reggos); Selection from Paganini (Lehár); Minuet in A (Boccherini); Ballet Suite, Ein Fest im Gnomeneich (Wisteborn); Melody (Meisel); Neapolitan March (Gastaldon); Waltz, Goldschmidts Töchterlein (Fétras); Hungarian Dance (Drdla); Selection from The Geisha (Jones); Xylophone Solo, Polka Mazurka (Ramthor); March, Deutscher Geist (Zettli). In the interval at 12.15 p.m., News and Programme Announcements. 1.0, News. 1.40, Radio Report of the Fisheries at Horst. 2.0, Talk: The Joiner's Craft. 2.15, Talk: Old Coach Roads and New Motor Roads. 2.35, Economic Notes. 3.0, Programme for Young People. 4.50, News, Weather, and Time. 5.0, Song Recital by Alfred Kase: German Festival Song (Schliebold); Saerspruch (von Hausegger); Klage (Pitzner); Two Songs (Kieissig): (a) Unterm Hauskruzifixus. (b) Magna Mater; Four Poems by von Selchow (Riedel): (a) Für mein Volk, (b) Mein Schwur und Gebet, (c) Der Mann an der Tür, (d) Nach vorwärts schau'n. 5.30, Book Review. 5.50, Review of the Day's Events. 6.0, Transmission for all German Stations, relayed from Hamburg. 7.0, Talk: The Battle of Leipzig, 16th-18th October, 1813. 9.0, News. 10.0, Concert on Old and Modern Instruments (on Gramophone Records).

LINZ.—See Vienna.

LJUBLJANA

522 kc/s, 574.7 metres; 7 kW.—6.0, Religious Talk. 6.30, Literature Lesson. 7.0, Song Recital. 7.45, Flute Solos. 8.30, Concert by the Station Orchestra. 9.0, Time, News, and Dance Music. 10.0 (approx.), Close Down.

LUXEMBOURG

352 kc/s, 1,191 metres; 200 kW.—Luxembourg Evening. 7.0 p.m., Symphony No. 3—the Eroica (Beethoven) on Gramophone Records. 8.0, Quartet for Oboe, Violin, Viola and Cello (Mozart). 8.20, Concert by the Radio Orchestra, conducted by Henri Pennis: Carnival Overture (Dvorak); Spanish Suite (Albeniz-Salabert); Galop (Liszt). 8.50, News. 9.0, Song Recital. 9.30, Concert by the Radio Orchestra: March, Letzeburg de Letzeburger (Albrecht); Danse des petites poupées (Mertens); Ballade (Foods). 9.50, News in German. 10.0, Gramophone Music. 10.15, Dance Music.

LWOW

788 kc/s, 381 metres; 16 kW.—6.5 p.m., Announcements and Gramophone Music. 6.25, See Warsaw. 6.40, Programme Announcements. 7.0, See Warsaw. 10.5, Gramophone Music. 10.30 (approx.), Close Down.

LYONS

LA DOUA, 644 kc/s, 465.8 metres; 1.5 kW.—7.40 a.m., Radio Gazette for Lyons and the South-East. 8.30, Déjeûne (Denys Amiel). After the Programme, News.

MADRID

ARANJUEZ; EAQ; 10,000 kc/s, 30 metres; 20 kW.—10.30 p.m., Popular Music. In the interval at 10.45, Radio Chronicle. 11.40, Light Music. 12 Midnight till Close Down, Programme in English by the I.B.C. Concert by the International Broadcasting Company (Ireland), Ltd., on behalf of the Hospitals Trust, Ltd. Signature Tune: Come back to Erin. Dream Waltz; It's just the same to me; Humming to myself; Rosa del Rio; The Land of Smiles; Kilma Waltz; Tiptoe through the Tulips; Arrogancia Andaluza; Signature Tune: Come back to Erin. 12.30 a.m. (Thursday), I.B.C. Good-night Melody.

MADRID

EAJ7, 707 kc/s, 424.3 metres; 2 kW.—7.0 p.m., Chimes, Exchange, Programme for Women, Poetry Reading, and Request Gramophone Music. 8.15, Topical Review. 8.30, Interval. 9.30, Chimes, Time, and Topical Review. 9.40 (approx.), Concert by the Philharmonic Orchestra, conducted by Perez Casas. 11.45, Topical Review. 12 Midnight, Chimes and Close Down.

MALMO.—See Stockholm.

MILAN.—See Turin.

MORAVSKA-OSTRAVA

1,137 kc/s, 263.8 metres; 11 kW.—3.0 p.m., Concert by the Station Orchestra, conducted by Plichta. Selection from I Pagliacci (Leoncavallo); Waltz from Der Rosenkavalier (Richard Strauss); Polichinelle (Provaznik); Egyptian Dance (Friml); Selection from The Flower of Hawaii (Abraham); Vampire Dance (Smatek); March (Drabek). 3.50, See Prague. 4.35, Gramophone Music. 4.45, See Prague. 4.55, Gramophone Music. 5.0, Talk. 5.15, See Prague. 5.25, Concert by a Country Band. 6.0 to 9.15, See Prague. 9.15 (approx.), Close Down.

MOSCOW

TRADES UNION, 300 kc/s, 1,000 metres; 100 kW.—10.45 a.m., Weather Forecast. 1.45, p.m., Weather Report. 2.0, Concert of Light Music with Talk. 3.0, English Lesson. 3.30, Readings by Poets and Authors from their own Works, followed by Reading from The Snow Storm (Pushkin). 4.30, Dramatic Programme for Young People. 5.30, Telemikovsky Concert, conducted by George Sebastian. Symphony, No. 1; Songs; Symphony No. 6. 8.0, News. 8.30, Programme Announcements. 8.55, Chimes from the Red Square. 9.5, Press Review. 10.0, Weather.

MOTALA.—See Stockholm.

MUHLACKER.—See Stuttgart.

MUNICH

563 kc/s, 533 metres; 60 kW. Relayed by Augsburg and Kaiserslautern, 536 kc/s, 560 metres; and Nürnberg, 1,256 kc/s, 239 metres.—3.30 p.m., Concert by the Quirin Huber Orchestra: Overture, Hocus-Pocus (Lenschner); Selection from The Mikado (Sullivan); Waldständchen (Heineke); Potpourri, Wiener Leben (Komzak); Waltz Intermezzo, Blütenzauber (Lindsay-Theiner); Travel Pictures from Old China (Percy); March, Freudenfeier (Blankenburg). 4.45 (from Nürnberg), Talk: Bavarian Soldiers in Greece. 5.5, Four Pianoforte Pieces, Op. 8 (Lampe), played by Julius Müller. 5.25, Reading: At the Cape of Good Hope (Rohrbach). 5.45, Time, Weather and Agricultural Notes. 6.0, Transmission for all German Stations, relayed from Hamburg. 7.0, Service for Customers—Variety Programme, followed by Dance Music. 9.0, Austria. 9.20, Time, Weather, News and Sports Notes. 10.0, Serenade, conducted by Erich Kloss. 11.0 (approx.), Close Down.

NAPLES.—See Rome.

NOTODDEN.—See Oslo.

OSLO

277 kc/s, 1,083 metres; 60 kW. Relayed by Fredriksstad, 815 kc/s, 368.1 metres; Hamar, 522 kc/s, 574.7 metres; Notodden, 671 kc/s, 447.1 metres; Porsgrunn, 662 kc/s, 453.2 metres; and Rjukan, 671 kc/s, 447.1 metres.—4.0 p.m., Gramophone Concert of Classical Music. 5.0, French Lesson. 5.30, Programme for Girls. 6.0, Announcements, Weather and News. 6.30, Talk arranged by the University. 7.0, Time Signal. 7.1, Extracts from Peer Gynt (Grieg) by the Station Orchestra. 8.0, Hermann Wessel Programme—Talk and Recitations, relayed from Bergen, 824 kc/s, 364 metres. 8.30, Agricultural Notes and Weather Report. 8.45, News. 9.0, Topical Talk. 9.15, Vocal and Instrumental Concert. 10.0, Dance Music on Gramophone Records. 10.30 (approx.), Close Down.

OSTERSUND.—See Stockholm.

PALERMO

558 kc/s, 537.6 metres; 8 kW.—7.0 p.m., Dopolavoro Notes, Tourist Talk, Agricultural Report and Giornale Radio. 7.20, Gramophone Music. In the interval at 7.30, Time and Announcements. 7.45, Orchestral Concert; Soloists, Hella Helt Di Gregorio (Soprano) and Castagna (Bassoon): Overture, Così fan tutte (Mozart); Soprano Solos: (a) Hindu Song (Rimsky-Korsakov). (b) Song and Serenade (Freire); A Night on the Bare Mountain (Mussorgsky); Talk; Bassoon Concerto (Mozart); Selection from Il carillon magico (Piek-Manguigalli); Soprano Solos: (a) La pastorella delle Alpi (Rossini). (b) Il bacio (Arditi); Selection from L'Arlesienne (Bizet). After the Concert, Light Music. 10.0, Giornale Radio.

PARIS

POSTE PARISIEN, 914 kc/s, 328.2 metres; 60 kW.—7.0 p.m., Popular Russian Songs on Gramophone Records. 7.15, Le Journal Parlé. 7.30, Concert. 8.5, Talk on Economics. 8.30, L'Age de raison—Play in Three Acts (Paul Vialar). 10.30, Dance Music. 11.0, News.

OCT. 18th WEDNESDAY continued

PARIS

RADIO PARIS, Call GFR, 174 kc/s, 1,725 metres; 75 kW.—7.30 a.m., Weather and Physical Culture. 7.45, Gramophone Records: Songs of the Ardennes (Jacquemin); La Jonnard (Moreau); March (Faregnol). 8.0, Weather and Press Review. 12 Noon, Educational Talk. 12.15 p.m., French Opera Music on Gramophone Records: Introduction to Act I of Fervaal (d'Indy); Symphonic Entr'acte from Messidor (Briean); Ballet Music from Le Miracle (Hue). 12.30, Organ Recital, relayed from the Gaumont Palace: My, oh my (Revel); Flirt (Pippe); Suite, Hyde Park (Jalowicz); Night and Day (Porter). 1.0, Exchange, News and Weather. 1.5, French Opera Music on Gramophone Records (cont'd.): Two Acts from Bonna Vanna (Février); Extracts from Pelléas et Mélisande (Debussy); Two Melodies from Ariane et Barbe-Bleue (Dukas). In the interval at 1.30, Exchange. 2.0, Exchange. 3.45, Exchange and Market Prices. 6.30, Agricultural Talk. 6.45, Book Review. 7.0, Medical Talk. 7.20, Concert: Arab Melody (Glazunov); Allegro (Galuppi); Mazurka (Chopin); My Rose (Fillis); Gipsy Romance (Baldi); Two Acts from Moinoua (Beydts); La chère Maison (Balcroze); La Mère Jeanne (Dupont). 7.50, Commercial Prices and News. 8.0, Reading. 8.30, News and Weather. 8.40, Fashion Review. 8.45, Symphony Concert, conducted by Eugene Bigot: Overture, The Bartered Bride (Smetana); Pianoforte Concert in F Minor (Chopin); Scherzo (Lalo); Pieces for 'Cello and Orchestra: (a) Elegy (Fauré). (b) Spanish Serenade (Glazunov). (c) Allegro appassionato (Saint-Saëns); Symphony No. 7 (Schubert). In the interval at 9.15, Press Review and News.

PITTSBURGH

KDKA, 980 kc/s, 306 metres; 50 kW. Relay by W8XK on 48.86 metres and 25.27 metres.—7.30 p.m., KDKA Home Forum. 8.0, Programme to be announced. 8.15 to 9.30, New York Relay. 8.15, Utility Hall. 8.30, Dixie Days. 9.0, Betty and Bob. 9.15, Southern Symphonies. 9.30, Frances Ingram. 9.45, News and Markets. 10.0, Uncle Tom and Betty. 10.15, KDKA Kiddies' Klub. 10.30, Singing Lady, from New York. 10.45, Orphan Annie, from New York. 11.0, News, Piano Classique. 11.15, Sports, Pat Haley. 11.30, Pittsburgh Spotlights. 11.45 to 3.30 a.m., New York Relay. 11.45, Lowell Thomas. 12 Midnight, Amos 'n' Andy. 12.15 a.m. (Thursday), Gems of Melody. 12.30, Richard Kibber's Orchestra. 1.0, Crime Chuea. 1.30, Potash and Perlmutter. 1.45, Red Davis. 2.0, Warden Lawes. 2.30, John McCormack and Orchestra. 3.0, Ortiz Tirado. 3.30, Around the Cracker Barrel.

PORSGRUND.—See Oslo.

PRAGUE

614 kc/s, 488.6 metres; 120 kW.—3.0 p.m., See Moravská-Ostrava. 3.50, Marionette Play. 4.35, Gramophone Music. 4.45, Talk. 4.55, Gramophone Music. 5.5, Agricultural Report. 5.15, Talk for Workers. 5.25, News in German. 5.30, German Transmission: Talk for Workers. 6.0, Time and News. 6.10, French Lesson. 6.25, Popular Songs. 6.30, Talk on the following Transmission. 7.5, Suk Symphony Concert for the Composer's Sixtieth Birthday, relayed from the Smetana Hall by the Czech Philharmonic Orchestra, conducted by Jirak. Sokol March, Symphony No. 1 in E. Op. 14; Fantastic Scherzo, Op. 25; Praga-Symphonic Poem G, Op. 26, Pragunim. In the interval, Talk. 9.0, Time and News. 9.15, News in French. 9.30 (approx.), Close Down.

RADIO-SUISSE ROMANDE

SOTTENS, 743 kc/s, 403 metres, 25 kW.; and Geneva, 395 kc/s, 760 metres.—6.0 to 6.15 a.m. (from Lausanne), Gymnastics. 11.28, Time Signal from Neuchâtel Observatory. 11.30, News and Weather. 11.40 (from Geneva), Gramophone Music. 12 Noon (from Geneva), Financial News. 12.10 p.m. (from Geneva), Gramophone Music. 1.0 to 2.28, Interval. 2.28, Time Signal from Neuchâtel Observatory. 3.0, Programme from Schweizerischer Landessender. 5.0 (from Lausanne), Programme for Children. 6.0 (from Geneva), Science Talk: Modern Photography. 6.20, Photographic Notes. 7.0 (from Geneva), Georges Dandelot Concert Trio: Three Waltzes for Two Pianofortes: (a) Romantic Waltz, (b) Fantastic Waltz, (c) Rocooco Waltz. 7.25, Light Music by the Radio Suisse Romande Orchestra, conducted by Robert Echenard. 8.30 (from Geneva), Gramophone Concert. 9.0, News and Weather. 9.10 (from Geneva), Talk: The Work of the League of Nations. 9.30 (approx.), Close Down.

REYKJAVIK

250 kc/s, 1,200 metres; 21 kW.—11.0 a.m., Weather Forecast. 1.15 p.m., Variety Programme. 4.0, Weather Forecast. 8.10, Weather Forecast. 8.20, Music and Announcements. 9.0, Light Music. 10.0, Time and News. 10.30, Violin Solo by Thorarinn Gudmundsson, with Arias on Gramophone Records.

RJUKAN.—See Oslo.

ROME

Call 1R0, 680 kc/s, 441 metres; 50 kW. Relay by Naples, 941 kc/s, 319 metres; Milan (Vigentino), 662 kc/s, 453.2 metres, from 8.0 p.m. (approx.); and 2R0, 11,810 kc/s, 25.4 metres, from 4.15 p.m.—12 Noon to 1.0 p.m., Concert of Light Music by the Station Orchestra. In the interval from 12.30 to 12.45, Giornale Radio and Exchange. 1.0, Time and Announcements. 3.30, Children's Radio Review. 3.55, Giornale Radio, Exchange, and Report of the Royal Geographical Society. 4.10, Weather. 4.15 to 5.0, Concert of Light Music by the Station Orchestra. 5.40 (Naples), Shipping and Sports Notes. 5.45, Dopolavoro Announcements and Tourist Talk. 5.57, Report of the International Institute of Agriculture (in Italian and English). 6.10, Agricultural Notes and Wheat Market Report. 6.20, News in Foreign Languages. 6.40, Giornale Radio. 7.0, Time, Announcements, and Gramophone Records. 7.15, Medical Talk. 7.30, Giornale Radio and Sports Notes. 8.0, The Girl of the Golden West—Opera in Three Acts (Puccini), relayed from the Argentine Theatre. In the intervals, Talk and Announcements. After the Opera, Giornale Radio.

SALZBURG.—See Vienna.

SCHENECTADY

WGY, 790 kc/s, 379.5 metres; 50 kW. Relay at intervals by W2XAF on 31.48 metres and by W2XAD on 19.56 metres.—7.30 p.m., Two Seats in the Balcony, from New York. 8.0 to 8.15, Grande Trio, from New York. 12.45 a.m. (Thursday), Stock Reports. 1.0 to 2.30, New York Relay. 1.0, Popular Programme. 1.30, Popular Programme. 2.0, Musical Programme. 2.30, Variety Programme. 3.0, Popular Programme, from New York. 3.30, Ship of Joy, from New York, followed by Programme Resumé.

SCHWEIZERISCHER LANDESENDER

BEROMUNSTER, 653 kc/s, 459 metres; 60 kW; Basle, 1,229 kc/s, 244.1 metres; and Berne, 1,220 kc/s, 245.9 metres.—5.50 to 6.5 a.m. (from Berne), Gymnastics. 11.0 (from Berne), Chamber Music on Gramophone Records. 11.29, Time from Neuchâtel Observatory. Weather and News. 11.40 (from Berne), Italian Opera Music on Gramophone Records. 12.25 p.m. (from Berne), Time, Weather and Exchange. 12.30 (approx.) to 2.30, Interval. 2.30 (from Berne), Gramophone Concert. 3.0 to 5.30, Programme from Berne. 3.0, Programme to be announced. 3.30, Lute, Violin and Song Recital. 4.0, Suite from L'Arlésienne (Bizet), on Gramophone Records. 4.30, Old Music for Violin, Oboe, Clarinet, Horn and Bassoon. 5.0, Programme for Children. 5.30 (from Zurich), Talk on Cosmetics. 6.0 (from Zurich), English Lesson. 7.0 (from Basle), Recital of Music for Two Pianofortes. 7.30 (from Basle), Schubert and Franz Song Recital. 8.5, Weather and News. 8.15 (from Basle), Recital of Violin Sonatas. 9.0 (from Basle), Die Vierte Wand (The Fourth Wall)—Grottesque (Zimmer). 9.20 (approx.), Close Down.

SOTTENS.—See Radio-Suisse Romande.

STOCKHOLM

689 kc/s, 436 metres; 55 kW. Relay by Boden, 244 kc/s, 1,229.5 metres; Göteborg, 932 kc/s, 322 metres; Hörby, 1,166 kc/s, 257 metres; Motala, 221.5 kc/s, 1,354.4 metres; Östersund, 389 kc/s, 770 metres; and Sundsvall, 554 kc/s, 542 metres.—12 Noon to 12.30 p.m., Broadcast for Schools. 4.5 (from Göteborg), Provincial Programme. 4.45, The Practical Corner. 5.0, Gramophone Music. 5.55, Talk. 6.15, Weather and News. 6.30, Report on the Disarmament Conference, relayed from Geneva, 395 kc/s (760 metres). 7.0, The Ninth Symphony in D (Mabler), by the Stockholm Symphony Orchestra, conducted by Václav Talich. 8.20, Reading (G. K. Chesterton). 8.45, Weather and News. 9.0, Dance Music, relayed from the Bern Hall. 10.0 (approx.), Close Down.

STRASBOURG

869 kc/s, 345 metres; 11.5 kW.—11.30 a.m., Gramophone Music. 12.45 p.m., News. 1.0, Time and Exchange. 1.5, Gramophone Concert. Selection from Coppélia (Delibes); Extract from Les saltimbanques (Ganne); Selection from Véronique (Messager); Two Melodies; Selection from Sylvia (Delibes); Two Waltzes: (a) Estudiantina (Waldteufel). (b) Gold and Silver (Lehar); Wiener Praterleben (Translatour); Tesoro mio (Beccucci); Le cygne (Saint-Saëns); Clair de lune from Werther (Massenet); Selection from Miss Decima (Audran). 2.0, Interval. 4.45, Talk: The most popular Electrical Equipment. 5.0, Concert of Light Music by the Station Orchestra, conducted by Roskam. 6.0, Trio Concert, relayed from Lille, 1,130 kc/s, 265 metres. 7.0, Talk: Educational

Centres for Tubercular Patients. 7.15, Talk in German: The Palm Days of the Trade Guilds. 7.30, Time and News. 7.45, Gramophone Records. 8.0, Press Review in German and Lottery Results. 8.30, Music by Alsatian Composers. The Station Orchestra and Soloists, conducted by Maurice de Villars. Suite in D minor (Erh); Two Melodies (Erh): (a) Berceuse, (b) La barque; Menuet; Cette galant (Erh); Ronde de nuit (Erh); Cette petite (Gross); D'r Hans (Gross); Scènes foraines dans un village d'Alsace (Felix Klein); Filleuse (Gross); Berceuse (Gross); Pastorale (Schirle); Fileuse (Schirle); A la Source du Mont Sainte-Odile (Schirle); Two Melodies (North); Asiatic Suite (Pohl); Sex-tet for Strings (Adams). In the interval at 9.30 (approx.), Press Review. 10.30, Orchestral Concert, relayed from the Grand Kléber Tavern: Novelty March (Polloud); Waltz, Les sirènes (Waldteufel); Overture, Zampa (Hérold); Lehar Potpourri (Hraby); Selection from La fille de Madame Angot (Lecocq); Potpourri Successes of 1929-1930 (Dostal). 11.30 (approx.), Close Down.

STUTTGART

832 kc/s, 360.5 metres; 60 kW. Relay by Freiburg, 527 kc/s, 570 metres.—12.15 p.m., See Frankfurt. 12.25, Time and News. 12.35, Concert of Modern Operetta Music by the Station Orchestra, conducted by Seyfert: Overture, Wiener Frauen (Lehar); Selection from White Horse Inn (Stolz-Benatzky); Waltz, Lustiges Wien (Meisel); Selection from Wild Violets (Stolz). 1.30, See Frankfurt. 2.30 (from Mannheim), German Songs of the Seventeenth and Eighteenth Centuries: Recital by Gustav Knörzer (Bass). 3.0, Concert by the Station Orchestra, conducted by Gustav Gölich: Overture, Hans Sachs (Lortzing); Ballet Music from Rienzi (Wagner); Praeludium and Berceuse (Järnefeldt); Prayer and Dance from Olav Trygvason (Grieg); Waltz from Faust (Gounod); Overture, Gri-Gri (Lincke); Funkgeister Potpourri (Noack); Waltz, Gold and Silver (Lehar); Ländliche Suite (Armandola); Overture, Berlin, wie es weint und lacht (Conradi); March, Jagdabenteurer (Schrammel). 5.0, German for Germans. 5.20, See Langenberg. 5.35, Schultes-Berthel talks about his friend Ludwig Thoma. 5.50, Time and Announcements. 6.0, Transmission for all German Stations, relayed from Hamburg. 7.0 to 9.0, See Frankfurt. 9.0, See Munich. 9.20, Talk: Things you should know. . . 9.30, See Frankfurt. 9.45, News. 10.0, See Frankfurt. 11.0, Serenade. 12 Midnight (approx.), Close Down.

SUNDSVALL.—See Stockholm.

TOULOUSE

779 kc/s, 385 metres; 8 kW.—6.0 p.m., News. 6.15, Accordion Solos. 6.30, Songs from Sound Films. 6.45, Orchestral Music: Selection from Le petit duc (Lecocq), and La fille de Madame Angot (Lecocq). 6.50, Talk. 7.0, Spanish songs. 7.15, News. 7.30, Scènes alsaciennes—Orchestral Suite (Massenet). 7.45, Popular Songs. 8.0, Military Music. 8.15, Opera and Opéra-Comique Music: Printemps qui commence, from Samson et Delilah (Saint-Saëns); Duet from Aida (Verdi); Chorus from Cavalleria rusticana (Mascagni); Je suis Escamillo, from Carmen (Bizet); Elle ne croyait pas, from Mignon (Thomas); O messager des Dieux, from Thaïs (Massenet); Paresseuse fille, from Faust (Gounod). 8.45, Music by La Sirene Toulousaine, conducted by Ichac. In the interval, Airs from Operettas. 10.15, North African News. 10.30, Concert for Listeners in Morocco. 11.0, Request Music. 11.15, Dance Music. 12 Midnight, News. 12.5 a.m. (Thursday), Argentine Music. 12.15 Spanish Songs. 12.30 (approx.), Close Down.

TRIESTE

1,211 kc/s, 247.7 metres; 10 kW.—4.15 p.m. till Close Down, See Turin.

TRONDHEIM.—See Oslo.

TURIN

1,096 kc/s, 273.7 metres; 7 kW. Relay by Milan, 905 kc/s, 331.5 metres; Genoa, 959 kc/s; 312.8 metres; and Florence, 599 kc/s, 500.8 metres.—4.15 p.m., Song Recital by Eleonore Visciola (Soprano) and Nicolai (Mezzo-Soprano). 5.0 to 5.5, Weather. 5.45, Giornale Radio. Dopolavoro Announcements, and Gramophone Music. 6.0, Time, Tourist Talk, and Gramophone Music. 6.10, Agricultural Notes, and Wheat Market Report. 6.20, News in Foreign Languages. 6.40, Gramophone Music. 7.0, Announcements, Giornale Radio, and Weather. 7.15, Medical Talk. 7.30, A Comedy in Three Acts. After the Comedy, Dance Music. 10.0, Giornale Radio.

VATICAN CITY

15,120 kc/s, 19.84 metres (Morning) and 5,969 kc/s, 50.26 metres (Evening); 10 kW.

—11.0 to 11.15 a.m., Religious Information in Spanish. 8.0 to 8.15 p.m., Religious Information in Italian.

VIENNA

581 kc/s, 517 metres; 100 kW. Relay by Graz, 852 kc/s, 352.1 metres; Innsbruck, 1,058 kc/s, 283 metres; Klagenfurt, 662 kc/s, 453.2 metres; Linz, 1,220 kc/s, 245.9 metres; and Salzburg, 1,373 kc/s, 218.5 metres.—10.30 a.m., Concert by the Wiener Symphoniker, conducted by Josef Holzer. Soloist: Adolf Müller (Flute): March, Furchtlos im treu (Fück); Overture, Das Modell (Suppé); Flute Solo: Liebeslied (Titl); Zigeunerfest (Lehar); Volksliedchen (Komzak); Märchen (Komzak); Waltz, The Blue Danube (Joh. Strauss); Von Pontius zu Pilatus (Morena); Geh', Alte, schau (Schubert-Berté); Spanish Waltz (Hellmesberger); Zauberbild (Meyer-Helmund); Hehr ma mit (Sieczynski); Potpourri, Tango un Mitternacht (Komjati); Waltz, Wiener Bürger (Ziehrer). In the interval at 10.55, Weather. 12 Noon, Time and News. 12.10 p.m., Gramophone Concert: In Penseroso (Händel); Impromptu for Piano-forte (Schubert); Spring Song (Gounod); Zapateado (Sarasate); Aria from Ernani (Verdi); Lohengrin's Narrative from Lohengrin (Wagner); Ave Maria from Otello (Verdi); Aria from The Flying Dutchman (Wagner); Waltz from Naïfa (Dolihes-Dohnanyi). 2.0, Time, Weather, Market Prices and Exchange. 2.20, Talk: Spices and their Synthetic Imitations. 2.35, Orchestral Concert on Gramophone Records: Viennese Folk Music (Komzak); Selection from Les Mousquetaires au Couvent (Varney-Tavan); Dance of the Dervishes (Bendix); Musira proibita (Gastaldon); Liebessehnen (Michaëlis); Potpourri of Children's Songs (Robrecht); Schreibe deine Liebste dir (Benes); Melody (Santengini). 3.15, Recitation. 3.40, Talk: The Kindergarten Teacher and her Work. 4.5, Contemporary Austrian Composers—Alexander Spitzmüller Concert by the Rothschild Quartet. Soloists: Mari- anne Mislak-Kapper (Soprano), Hngo Burg-hauser (Bassoon), and Hans Wagne (Piano-forte). Prelude and Double Fugue, Op. 7, for Piano-forte; String Quartet, Op. 8; Three Songs: (a) Taggesang, (b) Jahreszeit, Op. 10; (c) Plötzenspieler vom Nil; Divertimento breve, Op. 6, for Two Violins, Viola, Bassoon and Piano-forte. 4.55, Talk: Sailing Championships. 5.10, Health Talk. 5.35, Talk for Workers. 6.0, Military Band Concert: Mein Österreich (Richter); Festival Overture (Suppé); Meleta-Marsch (Wagner); Vauouin-Jubiläum-Festmarsch (Kastner); Strauss Operetta Potpourri (Schlögl); Dr. Dollfus Marell (Thann); Waltz, Geliebts-kinder (Ziehrer); Jungdeutschemer-Marsch (Richter). In the interval at 6.25, Time, Weather and Programme Announcements. 7.15, A Lecture by Raouf Aslan. 7.55, Topical Talk. 8.10, Joseph Marx Song Recital by Hans Duhan (Baritone), with the Composer accompanying; Japanisches Regenlied; Sendung; In meiner Träume Heimat; Selige Nacht; Wie reizend bist du; Dezember; Der Dichter; Abends; Wie enist; Bitte; Gebet; An einen Herbstwald Regen; Windrädler; Der Ton. 8.55, News. 9.10, Report in Esperanto on the International Conference to be held in Vienna and Budapest in 1934. 9.25, Concert Relay: Part I—From the Lehar Hall. Part II—From the Hotel Krantz-Ambassador. After the Programme, News.

WARSAW

212.5 kc/s, 1,411 metres; 120 kW.—10.57 a.m., Time Signal and Fanfare from St. Mary's Church, Cracow. 11.5, Dance Music. 11.30, Radio Journal and Weather. 11.35, Dance Music (cont'd.). 12 Noon, Interval. 2.30 p.m., Economic Notes. 2.40, Rachmaninoff and Liadov Music on Gramophone Records. 3.10, Talk for Children: The Flight of the Migratory Birds to Africa. 3.25, Talk: Children's Letters. 3.40, Talk on the Polish Language. 3.55, Song and Cello Recital by Mme. Zwidryn (Soprano) and Danczowski, relayed from Lwow, 788 kc/s, 381 metres. 4.50, Agricultural Correspondence. 5.0, Educational Talk. 5.20, Orchestral Concert: Mazurka (Kaczynski); Melody (Wigiecki); Oberkis and Polka (Stromberg); Waltz (Kaczynski); Polka Mazurka (Slaski); Mazurka (Piorkowski); Two Dances (Stromberg); Polka (Kaczynski); Waltz and Dance (Stromberg); Potpourri of Polish Dances (Kaczynski); Melody (Piorkowski); Polka (Slaski). 6.5, Miscellaneous Items. 6.25, Talk: Readings in the Winter Programme. 6.40, Programme Announcements. 6.45, Radio Journal. 7.0, Concert by a Guitar Orchestra with Wysocki (Songs). 8.0, Talk: Commercial Life in Poland. 8.15, Pianoforte Recital by Szymponka: Variations in F minor (Haydn); Sonata Appassionata (Beethoven); Nocturne and Cracovienne fantastique (Paderewsky); Ma chérie (Chopin-Liszt); Spinning Song from The Flying Dutchman (Wagner). 9.0, Sports Notes. 9.10, Dance Music from the Adria Café. 10.0, Weather and Police Notes. 10.5, Dance Music (cont'd.).

ZAGREB

977 kc/s, 307 metres; 0.75 kW.—6.10 p.m., Talk: The Esperanto Language. 6.30, Announcements. 7.0, Concert relayed from Ljubljana. 9.0, News. 9.15, Dance Music. 10.0 (approx.), Close Down.

ZURICH.—See Schweizerischer Landessender.

ALGIERS

824 kc/s, 364 metres; 13 kW.—7.20 p.m., Songs from Operettas. 7.55, News. 8.0, Time and Lottery Results. 8.10, Widow Durosel—One Act Comedy (Bisson and Mars). 8.45, News. 8.50, Talk. 9.5, Request Gramophone Records. 9.30, News. 9.35, Request Gramophone Records. 9.55, News. 10.0, Eastern Music.

ATHLONE

725 kc/s, 413 metres; 60 kW. Relayed by Cork, 1,337 kc/s, 224.4 metres.—1.30 to 2.30 p.m., Time Signal, Weather Report, Stock Report and Gramophone Concert. 6.0, Programme for Children. 6.40, News. 7.0, French Lesson. 7.15, Recitation of Poems. 7.30, Time. 7.31, Violin Duets. 8.0, Song Recital by P. J. O'Toole (Tenor). 8.15, The Station Orchestra. 8.45, Pianoforte Recital by Dina Copeman. 9.5, Soprano Solos by Alice Rafter. 9.20, The Station String Orchestra. 9.30 to 10.30, Programme by the I.B.C. (Ireland). Ltd. 8.30, Variety Concert: Spanish Sweetheart (Evans); Jealousy (Gade); Flor de Cuba (Conyer); Zigeuner, you have stolen my heart (Egen). 9.45, Programme of Dance Music: I cover the Waterfront (Heymann); Hold me (Schuster); Let's call it a Day (Brown); You're mine you (Green). 10.0, Concert arranged by the International Broadcasting Company (Ireland), Ltd.: The Wedding of the Rose (Jessel); Spanish Gypsy Dance (Chapini); Pianoforte Solo: Wasps (Holbrooke); Racing Commentary; Frühlingsstimmen (Joh. Strauss); Harlequinade (Squire); Xylophone Solo: Dance of the Marionettes (Gaston); Selection from The Desert Song (Romberg). 10.30, I.B.C. Goodnight Melody, followed by News and Weather. 10.40, Irish Dance Band Music. 11.0 (approx.), Close Down.

BARCELONA

EAJ1, 860 kc/s, 348.8 metres; 8 kW.—6.0 p.m., Concert by the Station Trio: Selection from Los Claveles (Serrano); Serenade la bella Italia (Busquets); Polo gitano (Bretou); Nocturne, El caballero sin nombre (Granados); Rejas y flores (Vila); Schumann Potpourri (Füsté); Selection from La Villana (Vives). 7.0, Request Gramophone Music. 7.30, Exchange and Gramophone Music (cont'd.). 8.0, Gramophone Music and News. 9.0, Chimes from the Cathedral, Weather, Exchange, and Market Prices. 9.5, Concert by the Station Orchestra: March (Lincke); Waltz (Siede); Reverie du soir (Saint-Saëns); Minuet (Riho); Saturnales (Massenet); Overture, The Mastersingers (Wagner). 10.0, L'Angel de la guarda—Catalan Play in Three Acts (Solér). In the interval at 11.0, News. 12 Midnight (approx.), Close Down.

BARI

1,112 kc/s, 269.8 metres; 20 kW.—12.10 p.m., Concert from Turin. 1.0, See Rome. 3.30, Programme for Women. 3.50 to 5.0, See Rome. 5.35, News in Albanian. 5.45 (approx.) to 6.20, See Rome. 6.20, News in Albanian. 6.40 till Close Down, See Rome.

BASLE.—See Schweizerischer Landessender.

BELGRADE

697 kc/s, 430.4 metres; 2.8 kW.—6.0 p.m., Gramophone Music. 6.20, Address. 7.0, Instrumental Concert: Quartet for Pianoforte, Violin, Viola and Cello (Leken); Septet (Saint-Saëns). 7.30, Gounod Concert for the Fortieth Anniversary of his Death. 9.0, Time and News. 9.10 (approx.), Cigány Music from the Dva Jelena Restaurant. 9.45, Gramophone Dance Music.

BERLIN

DEUTSCHLANDSENDER, REICHSENDER, 183.5 kc/s, 1,635 metres; 60 kW.—1.0 p.m., Gramophone Concert: Brandenburg Concerto No. 5 in D (Bach); Fugue in G minor (Bach); Arioso (Händel); Les petits riens (Mozart); Second and Third Movement from Symphony No. 3 in D (Schubert); Sclerzo in D (Brahms); Minuet in A (Brahms); Aria from Der Freischütz (Weber); Mondnacht (Schumann). 1.45, Programme for Children. 2.0, Programme for Young People. 2.30, Weather and Exchange. 2.45, Reading from Das kaiserliche (Paul Ernst). 3.0, Concert from Heilsberg. 4.0, Talk for Women. 4.20, Martin Grabert and Alexander Preuss Concert by the Station Chamber Choir, conducted by Hans Georg Görner. Soloists: Carola Farina-Gérard (Soprano) and Walter Prätorius (Tenor). 5.0, A Poem. 5.5, Variety Programme. 5.30, Talk. 5.50, Weather. 6.0, Transmission for all German Stations, relayed from Berlin (Funkstunde). 7.0, Today's Motto. 7.10 (approx.), Programme from Breslau. In the interval at 8.20, Talk on Ferdinand Bonn. 9.0, Weather and News. 9.45, Weather. 10.0, Programme from Berlin (Funkstunde). 11.30 (approx.), Close Down.

BERLIN

FUNKSTUNDE, 715 kc/s, 419.5 metres; 1.5 kW.—3.30 p.m., Haydn and Mozart Concert: Symphony concertante for Violin, Cello, Oboe, Bassoon and Orchestra (Haydn); Divertimento for Six Wind Instruments and Two Violins (Haydn); Symphony in G Minor (Mozart). 4.30, Anecdotes about King Friedrich Wilhelm I. 4.50, Travelogue: Through Southern Arabia. 5.10, Song Recital by Benjamin Gigli on Gramophone Records: Arias from (a) Manon (Massenet), (b) The Pearl Fishers (Bizet), (c) Manon

Loscant (Puccini), and (d) Tosca (Puccini); Povero Pulcinella (Buzzi-Peccia); Funiculi-Funicula (Denza). 5.30, The Funkstunde informs its Listeners. . . . 5.35, Talk on Pomerania. 5.45, Topical Talk. 6.0, Transmission for all German Stations: National Artisans Festival Programme—Scenes and Songs of the Medieval Guilds, arranged by Rolf Reissmann. 7.5, On Board the Training Ship Goreh Fock—a Radio Report. 8.0 to 12 Midnight, Variety Programme. In the interval at 9.0 (approx.), News, and at 10.0 (approx.), Report by Herbert Seehofer. 12 Midnight, Close Down.

BERNE.—See Schweizerischer Landessender.

BERMUNSTER.—See Schweizerischer Landessender.

BODEN.—See Stockholm.

BODO.—See Oslo.

BORDEAUX-LAFAYETTE

986 kc/s, 304 metres; 13 kW.—6.15 p.m., Radio Journal. 7.40, Talk arranged by the International Labour Bureau. 7.55, Lottery Results. 8.0, Talk on Wine. 8.15, News. 8.30, Le Plancher des Vaches—Comedy in Three Acts (Jean Sarment).

BRATISLAVA

1,076 kc/s, 279 metres; 14 kW. 5.25 p.m., Selrammel Music. 5.55, Talk for Housewives. 6.0, See Prague. 7.10, Talk: The Relations between Czechoslovakia and Yugoslavia in the Past. 7.25, Programme to be announced. 9.0, See Prague. 9.45 (approx.), Close Down.

BREMEN.—See Hamburg.

BRESLAU

523 kc/s, 325 metres; 60 kW. Relayed by Gleiwitz, 1,184 kc/s, 253 metres.—11.0 a.m., Weather. 11.5, Concert by the Silesian Philharmonic Orchestra, conducted by Rischka: Overture Semiramis (Rossini); Spring Suite (Nevin); Selection from Undine (Lortzing); Serenade Op. 7 (R. Strauss); Waltz, Seid unschüchtern, Millionen (Joh. Strauss); March; Selection from Der Tenor der Herzogin (Künneke); Shawl-Polka (Joh. Strauss); Suite, German Baroque (Pachernegg); Overture, Frau Luna (Lincke). 12.45, Time and News. 1.10, Soprano Song Recital by Charlotte Ziegler: Songs (Brahms): (a) Juchhe, (b) Sonntag, (c) Jungfräulein, soll ich mit Euch gehn, (d) Feinsliebchen du sollst, (e) Dort in den Weiden steht ein Haus; Rosenlied (Eulenburg); (a) Monatrose, (b) Wilde Rose, (c) Rankende Rose, (d) Seerose, (e) Weiss und rote Rose. 1.35, Operetta Music on Gramophone Records: Selection from Die Fiedlermaus (Joh. Strauss); Two Airs from Musik und Liebe (Müller); (a) Mir hat ein Märchen heut geträumt, (b) Nun ist Frieden uns beschieden; Selection from The Land of Smiles (Lelari). 2.0, Agricultural Prices. 2.15, Book Review. 2.35, Talk: Hiking in Silesia. 2.45, Programme for Children. 3.15, Orchestral Concert, conducted by Popitz: Overture, Berlin, wie es weint und lacht (Conradi); Slav Rhapsody No. 2 (Friedemann); Komm zu mir (Gaulberger); Delirium-Walzer (Jos. Strauss); Polka Die Nachtigall (Popp); Flotte Postillon (Rathke); Potpourri, Was wir lieben (Gaulberger); Ständchen (Jos. Strauss); Neue Pizzicati-Polka (Joh. Strauss); Waltz, Versehmte Liebe (Lincke); Savoyarde (Friedl-Lienz); Overture, Fatinitza (Suppé). 4.55, Agricultural Prices. 5.0, Topical Report. 5.25, Talks by Workers and their Leaders. 6.0, Transmission for all German Stations, relayed from Berlin (Funkstunde). 7.0, News. 7.10, Così fan tutte—Opera in Two Acts (Mozart), relayed from the Municipal Theatre. In the interval at 8.20, Commentary on the Opera. 9.40, Time and News. 10.5, Programme from Berlin (Funkstunde). 12 Midnight, Close Down.

BRNO

878 kc/s, 342 metres; 35 kW.—3.0 p.m., Concert by the Station Orchestra, conducted by Janota: Overture, El Guarany (Gomez); Romantic Suite (Bullerian); Andalusian Romance, Op. 22, No. 3 (Sarasate); Spanish Dance No. 8, Op. 26 (Sarasate); Rhapsody in A minor (Dvorak). 3.50, See Prague. 4.15, Programme for Young People. 4.25, Gramophone Music. 4.35, See Prague. 4.50, Gramophone Music. 5.0, Theatre and Film Review. 5.15, See Prague. 5.25, German Transmission: News, Geological Talk and Talk for the Housewife. 6.0, See Prague. 7.10, See Bratislava. 7.25, Programme to be announced. 8.25, Concert by the Station Orchestra. 9.0, See Prague. 9.45 (approx.), Close Down.

BRUSSELS (No. 1)

I.N.R., 590 kc/s, 509 metres; 15 kW.—12 Noon, Concert by the Small Station Orchestra, conducted by Leemans. Overture, Si j'étais roi (Adam); Printemps d'amour (Kalkman); Ballet Music from Les deux

pigeons (Messenger); Pianoforte Solos (Chopin): (a) Prelude, (b) Mazurka, (c) Waltz; Selection from Hérodiade (Massenet); Chanson de Josette (Desprez); Waltz, Just another Dream of you (Davis and Burke); Glow-Worm Idyll (Lincke). 1.0 p.m., Le Journal Parlé. 1.10, Gramophone Concert. 5.0, Concert by the Radio Orchestra, conducted by André, Foxtrot, China-town (Gerrebes); Menuet printanier (Desprez); Selection from Fatinitza (Suppé); Waltz (Fryberg); Selection from Hausel and Gretel (Humperdinck); Foxtrot (Rixner); Selection from Oh, Kay (Gershwin); Little Suite for Orchestra, No. 2 (Zlika). 5.30, Music Talk. 6.0, Talk for Housewives. 6.15, Gramophone Music. 7.15, Talk for Workers. 7.30, Sports Notes. 8.0, Cabaret Programme. 8.30, Gramophone Music. 8.45, Talk: on Co-operation. 9.0, Concert by the Station Orchestra, conducted by André: Hungarian March (Berlioz); Slav Dances (Bach); Violin Solo: Zigeunerweisen (Sarasate); Russian Dances (Bullerian); Spanish Dances (Fallá); Cello Solo: Harlequin (Popper); Popular Dances from The Bartered Bride (Smetana); Fantasia, Tempo tempo (Dostal). 10.0, Le Journal Parlé.

BRUSSELS (No. 2)

N.I.R., 887 kc/s, 338.2 metres; 15 kW. Programme in Flemish.—12 Noon, Gramophone Concert: Valse des fleurs (Tchaikovsky); Overture, Light Cavalry (Suppé); Ständchen (Schubert); Ave Maria (Schubert); Danse macabre (Saint-Saëns); Entry of the Gladiators (Blanckenburg). 12.45 p.m., Organ Recital, relayed from the Théâtre Roxy. Antwerp: Selection from Tannhäuser (Wagner); French Opera Potpourri; Flemish Fantasia; Toccata (Widor); Dances (D'Hooghe); Kálmán and Stolz Operetta Potpourri; Hungarian Rhapsody (Liszt). In the interval at 1.0, Le Journal Parlé. 1.30, Concert by the Small Station Orchestra, conducted by Leemans: March, King Cotton (Souza); Roses from the South (Strauss); Waltz, Très jolie (Waldfenfel); Selection from Il Trovatore (Verdi); Melody (Heymann). 5.0, Gramophone Concert. 5.45, Programme for Children. 6.30, Gramophone Concert: Overture, Poet and Peasant (Suppé); Selection from White Horse Inn (Stolz-Benatzky); Selection from Her Highness Commands (Stolz); Selection from Viktoria and her Hussar (Abraham); Melodies from The Love Parade (Schertzing). 7.10, News. 7.15, Talk. 7.30, Talk for Women. 8.0, Concert by the Radio Orchestra, conducted by André; Soloist, Van Schoot (Songs); K.V.R.O. Song; Spanish Caprice (Rimsky-Korsakov); Songs; Extracts from L'Arlesienne (Bizet). 8.45, Talk: A Journey down the Scheldt. 9.0, Gramophone Concert: Selection from The Merry Peasant (Fall); Hindi Song (Rimsky-Korsakov); Intermezzo from Cavalleria rusticana (Mascagni); Der Eriköng (Schubert); Wembley Military Tattoo; In a Chinese Temple Garden (Ketelbey); When the Guards are on Parade (Lori). 9.55, Evening Prayer. 10.0, Le Journal Parlé.

BUCHAREST

761 kc/s, 394 metres; 12 kW.—4.0 p.m., Concert by the Dinico Orchestra. In the interval at 5.0, Radio Journal. 6.0, Educational Programme. 6.20, Light Music on Gramophone Records. 6.40, Educational Programme. 7.0, Song Recital by Mme. Metaxa. 7.20, Pianoforte Concerto in E Flat (Liszt) by the Station Orchestra, conducted by Georgesco; Soloist, Mlle. Madeleine Cocoresco. 8.0, Talk. 8.15, Music by the Station Orchestra. 8.45, Radio Journal.

BUDAPEST

545 kc/s, 550.5 metres; 18.5 kW.—Also relayed on 840 metres from 6.15 (approx.) till Close Down.—4.30 p.m., Concert by the Opera House Orchestra, conducted by Fridl. 5.45, English Lesson. 6.15, Talk with Gramophone Illustrations: The Harem. 6.55, Programme to be announced. 7.30, Pianoforte and Cello Sonata Recital by Andreas Petri and Ludwig Frank: Sonata in F. Op. 69 (Beethoven); Sonata No. 1 in A minor (Schubert). 8.10, News. 8.30, Concert by the Paul Pertis Cigány Band from the Hotel Britannia. 9.15, Political Review. 9.30, Weather. 9.35, Song Recital by David Ney: Spring Song from The Valkyrie (Wagner); Lohengrin's Farewell (Wagner); Aria from The Twilight of the Gods (Wagner); Aria from Anna Karenina (Habay); Song (Lavotta); Song (Sandor); Rakoczi's Bekehrung (Kacsoli). 10.15, Dance Music from the Hotel St. Gellért.

CASSEL.—See Frankfurt.

COPENHAGEN

1,067 kc/s, 281 metres; 0.75 kW. Relayed by Kalundborg, 260 kc/s, 1,153.8 metres.—11.0 a.m., Time Signal and Chimes from the Town Hall. 11.2, Concert by the Harald Andersen String Ensemble, relayed from the Hotel

d'Angleterre. 1.0 p.m., Interval. 1.45, Jazz Music. In an interval at 2.30 (approx.), Reading (Jesper Ewald). 3.45, Programme for Boys. 4.20, Exchange and Fish Market Prices. 4.45, Talk. 5.15, Elementary English Lesson. 5.45, Weather. 6.0, News. 6.15, Time Signal. 6.16, Talk: Democracy and the Dictator. 6.45, Danish Lesson. 7.40, Concert by the Radio Symphony Orchestra, conducted by Nikolai Malko, relayed from the State Broadcasting Building. Soloists: Paul Hindemith (Viola) and Tenna Frederiksen Kraft (Songs); Symphony with Viola Obligato, Harold en Italie (Berlioz); Concerto, Op. 36, No. 4 (Hindemith); Songs: (a) Aria (Cesti), (b) Aria Alessandro nel ludio (Vinci), (c) Aria from La serva padrona (Pergolesi); Overture, The Thieving Magpie (Rossini). 9.15, News. 9.30, Reading. 9.50, Dance Music by the Tedy Petersen Band, relayed from the Wivex Restaurant. In an interval at 11.0, Time Signal and Chimes from the Town Hall. 11.30 (approx.), Close Down.

CORK.—See Athlone.

DANZIG.—See Heilsberg.

DRESDEN.—See Leipzig.

FECAMP

1,328 kc/s, 225.9 metres; 10 kW.—10.30 to 11.30 a.m., Programme in English by the I.B.C. Happy Hour: Part I: Concert of Scottish Music: Signature Tune, Selection from The Thistle (arr. Myddleton); Green Grow the Rushes O (Traditional); Wee Macgregor Patrol (Amers); Annie Laurie (Scott); The Glasgow Highlanders (arr. Diack); Heather Bloom (Kirby); Comin' through the Rye (arr. Smart); Selection of Scottish Airs. Part II: Dance Music: Tick, Toek; From me to you; Julien; Isn't it Heavenly?; I live for Love; A Woman should stick to her Man; Down the Old Ox Road; Signature Tune. 11.30, Programme in French. 1.30 to 6.0, Programme in English by the I.B.C. 4.30, The Nursery Corner. 5.0, Concert for Worthing and Littlehampton—I.B.C. Members' Request Hour. Signature Tune, The Night by the Sea; The Whistler and his Dog (Pryor); There's a Cabin in the Pines (Hill); Comin' through the Rye (arr. Smart); Air for the G String (Bach); Sleepy Time Down South; Hawaiian Twilight (Traditional); When the Wild, Wild, Roses bloom (Brown); My Ain Folk (Lemon). 5.30, Orchestral Concert for Brighton and Hove: Russian Rhapsody (Nussbaum); The Clock and the Dresden Figures (Ketelbey); The Match Parade (Welle); The Walsley Shrine (Sweetheart); My Mother's Garden (Hanley); Sheerheart, I'm dreaming of you (Desmond); Love Everlasting (Friml); Vienna, City of my Dreams (arr. Reeve); Signature Tune. 6.0, Programme in French. 10.0 (approx.) till Close Down, Programme in English by the I.B.C. 10.0, Dance Music: Signature Tune, The Bells of Normandy; Let's call it a Day; Oh! Johanna; Reflections in the Water; Avalon; It's Sunday down in Caroline; At the Old Pig and Whistle; Lover; Down the Old Ox Road; Isn't it Heavenly?; Learn to croon; Shuffle off to Buffalo; Down in the Valley; Old Man Harlem; I wake up smiling; Won't you stay to Tea?; P.C. 123—The Policeman's Song. 11.0, Talkie Time. Signature Tune, Sittin' in the Dark; Monte Carlo Medley; Sweetheart Darlin'; Sergeant Flagg and Sergeant Quirt; A nous la liberté; Selection from Il est charmant; Whoopee Medley; Let the World go drifting by; Love Songs of the Nile; Signature Tune. 11.30, Concert by the International Broadcasting Company (Ireland), Ltd.: Signature Tune. Come back to Erin; Over the Waves (Rosas); In a Country Lane (Coates); The Mountains of Mourne (French); My Lady Dainty (Hesse); By the Waters of Killarney (Aiken); The Birth of the Blues (Heunderston); Oh, could I but express in Song; The Busy Bee (Bendix); Signature Tune, Come back to Erin. 12.5 a.m. (Friday), Late News Bulletin in English. 12.10 (approx.), Club Concert for Deal and Walmer Listeners. Signature Tune, The Clum Song; Rocky Road (Gibbs); As long as you're there (Monaco); Alabama Song (Well); Just a Little closer (Meyer); Mama Inez (Grenet); Sweet Dreams Pretty Lady (Downey); Carry me back to Green, Green Pastures (Pepper); My Lucky Day (Parr-Davies); Lazybones (Meyer); Wedding of the Dragonflies (Meyer); I'll show you off (Hammerstein); Sweetheart Darlin' (Kahn); Happy Ending (Parr-Davies); I'm getting sentimental over you (Bollmann). 1.0, Dance Music: Signature Tune, Bells of Normandy; It was a Night in June; Spanish Eyes; What a Lady Josephine must have been; Stay out of my Dreams; Sweep; Sundown in a Little Green Hollow—A Girl like Nina; Under a Blanket of Blue; My Wishing Song; You did everything for me; Stormy Weather; I shall still keep smiling along; Have you had a Good Day To-Day?; Someone stole Gabriel's Horn; Adorable; They all do the Rumba; I raised my Hat. 2.0, I.B.C. Good-night Melody and Close Down.

FLENSBURG.—See Hamburg.

FLORENCE.—See Turin.

FRANKFURT

1,157 kc/s, 259.3 metres; 17 kW. Relayed by Cassel, and Trier, 1,157 kc/s, 259.3 metres.—12.15 p.m., Time and News. 12.25, Local News and Weather. 12.35, See Stuttgart. 1.30, Interval. 2.30, Weather Forecast. 2.40, Time and Market Prices. 3.0, Concert by the Station Orchestra, conducted

OCT. 19th THURSDAY continued

by Hans Rosbaud. Soloists: Luise Gmeiner (Pianoforte) and Helma Bohrmann (Soprano); Overture, Julius Caesar (Schumann); Pianoforte Concerto, Op. 54, in A minor (Schumann); Overture, Francesca da Rimini (Goetz); Overture, Die Landstreicher (Ziherer); Waltz from Die Chansonette (Dellinger); Gallop, Klipp-Klapp from Der Waldmeister (Joh. Strauss); Operetta Songs; Waltz, Traumland (Fueick); Polka, Yes and No (Genée); Overture, Der Göttergatte (Lehar); Operetta Songs; Laternen-Walzer (Lincke); March, Der Tausendkünstler (Blankenburg). 5.0 to 5.50, See Stuttgart. 5.50, Weather and News. 6.0, Transmission for all German Stations, relayed from Berlin (Funkstunde). 7.0, Topical Talk. 7.10, See Langenberg. 9.0, News. 9.20, See Stuttgart. 9.30, Time and News. 9.45 to 11.0, See Stuttgart. 11.0, Serenade. 12 Midnight, Close Down.

FREDRIKSSTAD.—See Oslo.

FREIBURG.—See Stuttgart.

GENEVA.—See Radio-Suisse Romande.

GENOA.—See Turin.

GLEIWITZ.—See Breslau.

GOTEBORG.—See Stockholm.

GRAZ.—See Vienna.

HAMAR.—See Oslo.

HAMBURG

806 kc/s, 372 metres; 1.5 kW. Relayed by Bremen, 1,112 kc/s, 269.8 metres; Flensburg, 1,319 kc/s, 227.4 metres; Hanover, 530 kc/s, 566 metres, and Kiel, 1,292 kc/s, 232.2 metres.—6.0 p.m., Transmission for all German Stations, relayed from Berlin (Funkstunde). 7.0 (from Hanover), From a Brunswick Music Publisher. Part I—A Radio Report. Part II—Chamber Music. Movement from the Pianoforte Trio No. 2, Op. 100 (Gurlitt); Divertissement No. 3, Op. 68, for Solo Flute (Kuhlau); Movement from the Scarlattiiana for Pianoforte Solo (Niemann); Baritone Solo: Beherzigung from the Goethe Lieder (Sommer); Movement from the Partita in B minor for Flute and Pianoforte (Therstappen); Baritone and Pianoforte Trio: Theodor Storm Music (Graener). 8.0 (from Hanover), Brunswick Skilled Trades. 9.0, Time, Weather and News. 9.20, Light Music by a Nazi Band, relayed from the Ostermann Restaurant. 10.0, Dance Music by the Small Station Orchestra and Three Pianofortes.

HANOVER.—See Hamburg.

HEILSBURG

1,085 kc/s, 276.5 metres; 60 kW. Relayed by Danzig, 662 kc/s, 453.2 metres.—11.30 a.m., Concert by the Königsberg Opera House Orchestra, conducted by Brückner. In the intervals at 12.1 p.m., Time and Weather, and at 12.20 and 1.0 News. 1.30 (from Danzig), Exchange. 2.0, Agricultural Prices and Exchange. 2.5, Concert by the Small Station Orchestra, conducted by Wilcken. Overture, Il Guarany (Gomez); Suite, Greenland (Juel Frederiksen); Ballet Suite from Coppélia (Delibes). Chromatic Waltz (Kockert); Ballet des parfums (Popy); Selection from Flotte Bursche (Plotow); Waltz, Mia bella Napoli (Oldsen); Suite, In a Fairy Realm (Kebelhey); Overture, The Queen's Kerkchief (Strauss). In the interval at 2.50, Talk: Re-opening of the University Extension Courses. 4.0, Programme for Young People. 4.25, Cello and Pianoforte Recital. 4.50 (from Danzig), Programme in Honour of Gustav Frensen's Seventieth Birthday. 5.15, Agricultural Prices. 5.25 (from Danzig), Agricultural Programme. 5.50, Weather. 6.0, Transmission for all German Stations, relayed from Berlin (Funkstunde). 7.0, News. 7.10, See Copenhagen. 8.0, German Folk Songs (Brahms), by the Station Choir, conducted by Firchow. 8.45, Eulenspiegel Suite of Five Pieces for Pianoforte (Deutsch), played by Erich Borschell. 9.0, News. 9.20, Elementary English Lesson.

HILVERSUM

1,013 kc/s, 296.1 metres; 7 kW up to 4.40 p.m., and 20 kW (from 5.40 p.m.).—Programme of the Algemeene Vereeniging Radio Omroep (A.V.R.O.). 11.41 a.m., Concert by the Wireless Orchestra, conducted by Nico Treep. Hands across the Sea (Souza); Scandinavian Suite (Frederiksen); Moonlight on the Bosphorus (Köpping); Glow-Worm Idyll (Siede); Ange d'Amour (Waldteufel); Gramophone Records: Grenadiers' March (Schertzing); Selection from Lilac Time (Schubert-Berté); The Rose Beetle goes a-wooing (Armandola); In the Mystic Land of Egypt (Kebelhey); On the Quarter Deck (Alford); Gramophone Records: Musical Comedy Revue (Fetras); Waltz (Ganne); Hearts and Flowers (Czibulka); Festival Overture (Leutner); Overture, Eine Nacht in Venedig (Joh. Strauss); The Marriage of the Winds (Hall); Navissemändel (Siede); La mousmée (Ganne); Old Conrades (Teike). 2.40, Dressmaking Lesson. 3.25, Gramophone Music. 3.40, Programme for Hospitals. 4.10, Dance Music by Bela Kiss and his Band, relayed from the Carlton Hotel, Amsterdam. 4.40, Programme for Children. 5.10, Concert of Light Music by Hans Schindler and his Orchestra. In an interval at 6.10, Sports Talk. 7.10, English Lesson. 7.40, Time and News. 7.45, Gramophone Music. 7.55, Concert by the Concertgebouw Orchestra, conducted by Pierre Monteux, relayed from the Concertgebouw Amsterdam. 8.55, Gramo-

phone Music.—9.10, Inquest—Radio Play. (Michael Barringer). 9.45, Concert of Light Music by Hans Schindler and his Orchestra. 10.40, News. 10.50, Gramophone Music. 11.40 (approx.), Close Down.

HORBY.—See Stockholm.

HUIZEN

160 kc/s, 1,875 metres; 7 kW until 3.40 p.m. Transmitted from Kootwijk, on 50 kW, from 3.40 p.m.—11.55 a.m. to 1.20 p.m., Programme of the Catholic Radio Society (K.R.O.). 11.55, Concert by the K.R.O. Orchestra, conducted by van 't Woud. Gipsy March (Lacome); Ballet Egyptian (Luigini); Minuet (Boccherini); Selection from Der Rastelbinder (Lehar); Selection from Tom Jones (German); Gramophone Music. Overture, Indra (Plotow); Rudolfsklänge (Strauss); Turkish Suite, No. 2 (Gauwin); Wedding Day on Troldhaugen (Grieg); Küssen ist kein' Sünd (Fyaler); Folies Bergère (Lincke). 1.40 till Close Down, Programme of the Christian Radio Society (N.C.R.V.). 1.40, Talk: Spare-Time Hobbies—Handwork. 2.40, Gramophone Music. 3.10 to 3.40, Interval. 3.40, Bible Reading and Sacred Music. 4.40, Handwork Lesson for Children. 5.10, Violin and Pianoforte Recital, by Mlle. Langeveld (Violin), Mlle. Stoker (Violin), and Van Erven Dorens (Pianoforte). Sonata in G Minor, Op. 2, No. 8 (Handel); Largo ma non tanto (Bach); Gramophone Music; Sonata, Op. 8, No. 4 (Haydn); Suite (Moskowsky); Allegretto (Sinding); Berceuse (Godard); Serenade (Godard). 6.10, Talk. 6.25, Gramophone Music. 6.40, Police Notes. 6.55, Religious News. 7.10, Press Review. 7.40, Choral Concert, conducted by de Rook. Gramophone Music in the inter-

11.0, See Frankfurt. 12 Midnight, Close Down.

LAUSANNE.—See Radio-Suisse Romande.

LEIPZIG

769.9 kc/s, 389.6 metres; 120 kW. Relayed by Dresden, 941 kc/s, 319 metres.—Transmits at intervals from 11.0 a.m., Concert by the Station Orchestra, conducted by Hilmar Weber: Soloist: Fritz Lorenz (Bassoon); Suite from The Taming of the Shrew (Ziherer); Theme and Variations, and Rondo for Bassoon (Lorenz); Slav Dances, Nos. 5 to 8 (Dvorak); Selection from Die Königskinder (Humperdinck); Waltz in A Flat (Chopin-Weber). 12.15 p.m., News and Programme Announcements. 12.30, Gramophone Concert: German Workers' Anthem (Unger); Two Arias from Aida (Verdi); Violin Solo: Melody (Tosti); Love Duet from Madame Butterfly Puccini); Pianoforte Solo: Rhapsody in B Minor (Brahms); Song: The Vagabond (Garmo); Overture, Anacreon (Cherubini). 1.15, News. 1.40, Film Review. 2.0, Discussion: Wonders of Modern Physics. 2.35, Economic Notes. 3.0, Concert by the Leipzig Symphony Orchestra, conducted by Blumer: Soloists: Erich Kindscher (Violin) and Theodor Blumer (Pianoforte); A German Overture (Beck); Selection from Andréa Chenier (Giordano); Two Pieces for Violin and Pianoforte (Paganini): (a) La Campanella, (b) Caprice No. 20; Two Movements from the Suite, Op. 4 (Ziherer); Concert Waltz (Glazunov); Two Pieces (Ries); Introduction and Tarantella for Pianoforte and Violin (Sarasate); Selection from Die Fledermans (Strauss). 4.30, Reading (Fon-



Hamburg's choral singing is one of the distinguishing features of this well-known station. The photograph shows the station's permanent choir presided over by Herr Gerhard Gregor.

vals. 8.40, Talk. 9.10, Organ Recital by Stretomini. In the interval at 9.40, News. 10.10, Gramophone Music. 11.10 (approx.), Close Down.

INNSBRUCK.—See Vienna.

KALUNDBORG.—See Copenhagen.

KIEL.—See Hamburg.

KLAGENFURT.—See Vienna.

KOSICE.—See Prague.

LANGENBERG

635 kc/s, 473 metres; 60 kW.—11.0 a.m., Programme from Stuttgart. 12.15 p.m., See Frankfurt. 12.25, News and Weather. 12.35, See Stuttgart. 1.30, Talk: Gas as an Economic Source of Power. 1.30, Song Recital by Wanda Achsel (on Gramophone Records): Senta's Ballad from The Flying Dutchman (Wagner); The Goose Maiden's Prayer from Die Königskinder (Humperdinck); Saffi's Song from The Gipsy Baron (Strauss); Zorika's Song from Gipsy Love (Lehar); Two Songs from Eine Nacht in Venedig (Strauss). 2.10, Talk: Country Sports for Schools. 2.30, Economic Notes. 2.50, Political Announcement. 3.0, See Frankfurt. 5.0 to 5.35, See Stuttgart. 5.35, Talk: Young Students and High School Pupils for Agriculture. 5.50, Announcements. 6.0, Transmission for all German Stations, relayed from Berlin (Funkstunde). 7.0, See Frankfurt. 7.10, Concert by the Station Orchestra, conducted by Buschkötter. Soloists: Lydia Hoffmann-Behrendt and Walter Schneiderhan (Violin). Overture, Lebensfreude (Schumann); Violin Solo: Burlesque in D Minor (Strauss); Mazepa (Liszt); L'apprenti sorcier (Dukas); Violin Concerto in D (Paganini); Oriental Rhapsody (Glazunov); Music after a Violin Etude (Mayseda-Hellmesberger). 9.0, See Frankfurt. 9.20, See Stuttgart. 9.30, News and Weather. 9.45 to 11.0, See Stuttgart.

5.0, News, Weather and Time. 5.0, Italian Lesson. 5.25, Sonata in F, Op. 8, for Violin and Pianoforte (Grieg), played by Franz Genzel and Alf Nestmann. 6.0, Transmission for all German Stations, relayed from Berlin (Funkstunde). 7.5, See Berlin (Funkstunde). 8.0, Concert of Yodels and Songs to the Lute. 9.0, News. 9.40, Talk: The Foundation of Racial Eugenics—Isolation, Selection and In-breeding.

LINZ.—See Vienna.

LJUBLJANA

522 kc/s, 574.7 metres; 7 kW.—6.0, Serbo-croatian Lesson. 6.30, Gramophone Music. 7.0, Music Lesson. 7.45, Accordion Music. 8.15, Song Recital. 8.45, Time and News. 9.0, Concert by the Station Orchestra. 10.0 (approx.), Close Down.

LUXEMBOURG

352 kc/s, 1,191 metres; 200 kW. German Evening.—7.0 p.m., Gramophone Records: Pianoforte Concerto No. 2 in C minor, Op. 16 (Rachmaninov), played by the Composer and the Philadelphia Philharmonic Orchestra. 7.45, Humorous Talk. 8.0, Concert by the Station Orchestra, conducted by Henri Pénis: Overture, Jocosia (Clemus); Ballad (Spies); Cradle Song (Pénis); Kaiserwalzer (Strauss); Suite No. 2 from L'Arlesienne (Bizet). 8.50, News in French. 9.0, Popular Concert. 9.50, News in German. 10.0, Gramophone Music. 10.15, Dance Music on Gramophone Records.

LWOW

788 kc/s, 381 metres; 16 kW.—6.5 p.m., See Warsaw. 10.5, Gramophone Music. 10.30 (approx.), Close Down.

LYONS

LA DOUA, 644 kc/s, 465.8 metres; 1.5 kW.—7.40 a.m., Radio Gazette for Lyons and the South-East. 8.30, Concert. Overture, The

Caliph of Bagdad (Boieldieu); Les Violons de M. de Conty (Woruser); Andante for Flute (Mozart); Aria from Figaro (Mozart); La mia Serenata (Staffelli); Chanson pour un petit cheval (Sévérac); Piece on an Old Air (Bordes); Alsatian Dance (Lévadé); Selection from Pique Dame (Suppé); Serenade from The Damnation of Faust (Berlioz); Sicilienne (Faure); Two Sonnets (Caplet); Réverie (Volpatti); Pieces for Ilarp (Tournier); La boune Aventure (Hubans); Symphonic Potpourri (Rossini); Horizon chimérique (Faure); Adoration (Filippucci); Selection from Tannhäuser (Wagner); Piece for Flute (Pillois); Frühlingsliebe (Strauss); Selection from Toreador (Adam). After the Concert, News.

MADRID

ARANJUEZ (EAQ), 10,000 kc/s, 30 metres; 20 kW.—10.30 p.m., Programme relayed from Madrid (EAJ7). 12 Midnight till Close Down, Programme in English by the I.B.C. Concert: I am so Anxious, Dear; Speak Easy; Fiesta; Soft Lights and Sweet Music; Hawaiian Waltz Medley; Song of the Vagabonds; Selection from Viktoria and her Hussar; Montana Moon. 12.30 a.m. (Friday), I.B.C. Goodnight Melody.

MADRID

(EAJ7), 707 kc/s, 424.3 metres; 2 kW.—7.0 p.m., Chimes, Exchange and Programme for Children. 8.15, Topical Review. 8.30, Interval. 9.15, English Lesson. 9.30, Chimes, Time, Topical Review and Dramatic Programme. 12 Midnight, Chimes. 1.0 to 2.0 a.m. (Friday), Programme in English by the I.B.C. Light Music and Dance Music: There's a Cabin in the Pines; Wiesbaden March (Anderson); If you'll say "Yes" Chérie; The Shadow Waltz; Song, Absent (Glen); The Gold-Diggers' Song (Dublin); Sittin' in the Dark (Greer); Bom-Ba-Diddy-Bom-Bom; The School Song; Sweetheart Darlin'; A Broken Rosary; Let Bygones be Bygones; I cover the Waterfront; I've told every little Star; In the Valley of the Moon; Hold Me! The Grass is getting Greener all the Time. 2.0, I.B.C. Good-night Melody and Close Down.

MALMO.—See Stockholm.

MILAN.—See Turin.

MORAVSKA-OSTRAVA

1,137 kc/s, 263.8 metres; 11 kW.—5.30 p.m., German Transmission—Educational Talk. 6.0, See Prague. 7.10, See Bratislava. 7.25, Programme to be announced. 9.0, See Prague. 9.45 (approx.), Close Down.

MOSCOW

TRADES UNION, 300 kc/s, 1,000 metres; 100 kW.—10.45 a.m., Weather. 1.45 p.m., Weather Report. 2.0, Concert of Ukrainian, Armenian, Latvian and Russian Music. 3.0, German Lesson. 3.30, Literary Programme. 4.30, Talk: The U.S.S.R. 5.30, Programme from the Meyerhold Theatre. 8.0, News. 8.30, Programme Announcements. 8.55, Chimes from the Red Square. 9.5, Press Review. 10.0, Weather.

MOTALA.—See Stockholm.

MUHLACKER.—See Stuttgart.

MUNICH

563 kc/s, 533 metres; 60 kW. Relayed by Augsburg and Kaiserslautern, 536 kc/s, 560 metres; and Nürnberg, 1,256 kc/s, 239 metres.—3.30 p.m., Concert by the Station Orchestra, conducted by Karl List: Overture, Alessandro Stradella (Plotow); Ballet Music from Coppélia (Delibes); Four Pieces for String Orchestra (Volkmann); Waltz, The Blue Danube (Strauss); Adagietto and Minuet (Bizet). 4.45, Talk: Illnesses of Farm Animals. 5.5 (from Nürnberg), Suite for Viola da Gamba and Harpsichord (Bettinger) played by Robert Grothe and Maria Fahmüller. 5.25, Talk: Germans in South America. 5.45, Time, Weather and Agricultural Notes. 6.0, Transmission for all German Stations, relayed from Berlin (Funkstunde). 7.0, Concert by the Concordia Zither Club. Soloist: Eyanell-Scarell (Mandoline). 7.50, Veit Stoss—Radio Play (Breuer). 9.0, Time, Weather and News.

NAPLES.—See Rome.

NOTODDEN.—See Oslo.

OSLO

277 kc/s, 1,083 metres; 60 kW. Relayed by Fredriksstad, 815 kc/s, 368.1 metres; Hamar, 522 kc/s, 574.7 metres; Notodden, 671 kc/s, 447.1 metres; Porsgrund, 662 kc/s, 453.2 metres; and Rjukan, 671 kc/s, 447.1 metres.—4.0 p.m., Orchestral Concert, relayed from Trondheim, 605 kc/s, 495.8 metres. 5.0, Divine Service. 6.0, Announcements, Weather and News. 6.30, Tenor Solos by Theodor Andresen: Aria from Joshua (Handel); Aria from Don Giovanni (Mozart); Aria from Der Freischütz (Weber); Aria from The Valkyrie (Wagner); Aria from Le Cid (Massenet). 7.0, Time Signal. 7.1, Agricultural Talk. 7.30, Orchestral Concert, relayed from Bergen, 824 kc/s, 364 metres. 8.0, Talk: The Political Situation. 8.20, Musical Programme. 8.40, Weather and News. 9.0, Topical Talk. 9.15, Concert of Light Music. 9.45 (approx.), Close Down.

OSTERSUND.—See Stockholm.

PALERMO

558 kc/s, 537.6 metres; 3 kW.—7.0 p.m., Dopolavoro Notes, Giornale Radio and Agricultural Report. 7.20, Gramophone Music. In the interval at 7.30, Time and Announcements. 7.45, Concert: Selection from The Dance of the Dragonflies (Lehár); Ideale (Tosti). 8.30, The Comedy of the Dumb Wife—Comedy in One Act (France). 9.0, Concert (cont'd.): Selection from Aequa cheta (Pietri); Selection from Le tre lüne (Lombardo). 10.0, Giornale Radio.

PARIS

POSTE PARISIEN, 914 kc/s, 328.2 metres; 60 kW.—7.0 p.m., Extracts from Plays (de Musset), on Gramophone Records. 7.15, Le Journal Parlé. 7.30, Programme for Children. 8.0, Talk. 8.5, Topical Talk. 8.35, Concert. 9.15, Gramophone Music. 10.30, News.

PARIS

RADIO-PARIS, Call CFR, 174 kc/s, 1,725 metres; 75 kW.—7.30 a.m., Weather and Physical Culture. 7.45, Gramophone Records: Melody (Waldteufel); Serenata (Toselli); Polka, Ziadunio; Gavotte (Hellmesberger). 8.0, Weather and Press Review. 12 Noon, Protestant Address. 12.30 p.m., Operetta Concert on Gramophone Records. Part I, Offenbach Music: Overture, Orpheus in the Underworld; Two Acts from La belle Héloïse; Six Melodies from The Tales of Hoffman; Part II, Audran Programme: Two Songs from Gillette de Narbonne; Two Melodies from Le Grand Mogol; Part III: Messenger Music: Two Acts from Veronique; Two Melodies from La Basoche; Air and Duet from L'amour masqué; Part IV: Hahn Music: C'est la Banquette; Comme Frère et Soeur; Nous avons fait un beau Voyage. In the interval at 1.0, Exchange, News, and Weather, and at 1.30, Exchange. 2.0, Exchange. 3.45, Exchange and Market Prices. 6.30, Agricultural Talk. 6.45; Talk: Compensation for Accidents at Work. 7.0, The Moral Crisis of our Day—Dialogue between Frédéric Lefèvre and Jules Romains. 7.20, Gramophone Records: La Poupée d'Arlequin (Darcy); L'Anneau d'argent (Chaminade); Chante, Rossignol, chante (Fieau); Selection from The Merry Widow (Lehár); Mai (Hahn); Come, Gipsy, from The Gipsy Princess (Kálmán). 7.45, German Press Review. 8.0, On purge Bébé—Play (Feydeau). In the interval at 8.40, Review by Christophe. 9.15, Press Review and News. 9.45, Gramophone Concert: The Nutcracker Suite (Tchaikovsky); Songs (Pierné): (a) Les trois petits Oiseaux, (b) Marionnettes, (c) Ils étaient trois petits Chats blancs; Concerto for Clarinets (Weber); Arioso from Bevenuto Cellini (Diaz); Spanish Rhapsody (Ravel).

PITTSBURGH

KDKA, 980 kc/s, 306 metres; 50 kW. Relayed by W8XK on 48.86 metres and 25.27 metres.—7.45 p.m., KDKA Home Forum. 8.0, Programme to be announced. 8.15, Quilting Party. 8.20, Words and Music, from New York. 8.45, Pennsylvania Women's Federation. 9.0, Betty and Bob, from New York. 9.15, Thursday Special, from New York. 9.30, News and Markets. 9.45, Thursday Special, from New York. 10.0, Federation of Women's Clubs, from New York. 10.15, KDKA Kiddies' Klub. 10.30, The Singing Lady, from New York. 10.45, Orphan Annie, from New York. 11.0, News and Piano Classique. 11.15, Sports, Pat Haley. 11.30, Pittsburgh Spotlights. 11.45, Lowell Thomas, from New York. 12 Midnight, Amos 'n' Andy, from New York. 12.15 a.m. (Friday), Marvellous Melodies. 12.30, Concert, Footlights, from New York. 12.45, Pathé News of the Air. 1.0 to 4.0, New York Relay. 1.0, Captain Diamond. 1.30, Adventures in Health. 1.45, Crooning Choir. 2.0, Death Valley Days. 2.30, Lady Esther Serenade. 3.0, Hands across the Border. 3.30, Echoes of the Palisades.

PORSGRUND.—See Oslo.

PRAGUE

614 kc/s, 488.6 metres; 120 kW.—3.0 p.m., See Brno. 3.50, Musical Programme for Children. 4.15, Talk for Workers. 4.25, Gramophone Music. 4.35, Elementary French Lesson. 4.50, Gramophone Music. 5.5, Agricultural Talk. 5.15, Talk on Foreign Utilities. 5.25, News in German. 5.30, German Transmission: Review of New Publications and Agricultural Programme. 6.0, Time and News. 6.10, Military Band Concert, conducted by Pesta. Overture, Orpheus in the Underworld (Offenbach); Selection from Dalibor (Smetana); Selection from The Gipsy Baron (Strauss); Intermezzo, Dance of the Fingies (Oberthor); Tattoo (Pesta); Potpourri of Russian Songs (Svarec). 7.5, Topical Talk. 7.20 to 9.0, Programme to be announced. 9.0, News, Review of the Day and Sports Notes. 9.15, Introductory Talk to the following transmission (in Czech and French); Smetana and his Works. 9.30, Symphonic Poem, Vysehrad, from the Suite, My Country (Smetana), by the Station Orchestra, conducted by Jeremias. 9.45 (approx.), Close Down.

RADIO-SUISSE ROMANDE

SOTTENS, 743 kc/s, 403 metres; 25 kW.; and Geneva, 395 kc/s, 760 metres.—6.0 to 6.15 a.m. (from Lausanne), Gymnastics. 11.28, Time Signal from Neuchâtel Observatory. 11.30, News and Weather. 11.40 (from Geneva), Gramophone Concert. 12 Noon

OCT. 19th THURSDAY continued

(from Geneva), Financial Notes. 12.10 p.m. (from Geneva), Gramophone Concert (cont'd.). 1.0, Interval. 2.58, Time Signal from Neuchâtel Observatory. 3.0 (from Geneva), Gramophone Concert. 4.0 (from Geneva), Concert by Students of the Conservatoire: Pianoforte Solos: (a) Barcarolle (Chopin), (b) Bourrée fantasque (Chabrier); Violin Solo: Aria, Satyres et Dryades and Valse caprice (Zsoltd). 4.30 (from Geneva), Gramophone Concert (cont'd.). 5.0 (from Lausanne), Concert. 5.30 (from Lausanne), Talk on Physical Culture. 5.55 (from Lausanne), German Lesson. 6.20 (from Lausanne), Tourist Report. 6.30 (from Lausanne), Agricultural Talk. 6.59 (from Lausanne), Weather Report. 7.0, Concert by the Radio-Suisse Romande Orchestra: Concerto grosso (Manfredini); Four Giggles (Mattheson-Theodore Appia); Suite for String Orchestra (Grieg); Serenade (Lauter); Pieces for String Orchestra (Theodore Appia). 8.0 (from Lausanne), Concert by a Russian Balalaika Orchestra, conducted by Tchernoyaroff. 9.0, News and Weather. 9.10 (from Geneva), Talk: The Work of the League of Nations. 9.30 (approx.), Close Down.

REYKJAVIK

1,200 metres; 21 kW.—11.0, Weather Forecast. 1.15 p.m., Variety Programme. 4.0, Weather Forecast. 8.10, Weather Forecast. 8.20, Music and Announcements. 9.0, Light Music. 10.0, Time and News. 10.30, Music by the Radio Trio, followed by Arias on Gramophone Records.

RJUKAN.—See Oslo.

ROME

Call 1R0, 680 kc/s, 441 metres; 50 kW. Relayed by Naples, 941 kc/s, 319 metres; Milan (Vigentino), 662 kc/s, 453.2 metres, from 7.45 p.m., and 2R0, 11,810 kc/s, 25.4 metres, from 4.15 p.m.—12.10 to 1.0, Concert relayed from Turin. In the interval from 12.30 to 12.35, Giornale Radio and Exchange. 1.6, Time and Announcements. 3.30, Children's Radio Review. 3.50, Giornale Radio and Exchange. 4.0, Talk. 4.10, Weather. 4.15 to 5.0, Violin and Song Recital: Maria Flori (Violin), Romano Rasponi (Baritone), and Guaido Caputo (Soprano). Violin Solos: (a) Pastorale (Bocherini), (b) Capriccio all'antica (Sinigaglia), (c) Burlesque (Somma); Baritone Solos: (a) Aria from The Damnation of Faust (Berlioz), (b) Aria from Germania (Franchetti), (c) Stornellata sull'Arno (Billi); Soprano Solos: (a) Zingarella spagnuola (Mercedante), (b) Rispetto (Benvenuti). (c) Aria from Fra Diavolo (Auber); Violin Solo: Scenes from the Czardas (Hrubý). 5.40 (Naples), Shipping and Sports Notes. 5.45, Dopolavoro Announcements and Tourist Talk. 6.10, Agricultural Notes and Wheat Market Report. 6.20, News in Foreign Languages. 6.40, Giornale Radio. 7.0, Time and Announcements. 7.15, Pianoforte Recital by Cesarina Buonerba. 7.45, Programme to be announced. 9.0, Pianoforte Recital by Ornella Puliti-Santoliquido: Four Popular Romanian Dances (Béla Bartók); Two Film Studies (Castelnovo-Tedesco): (a) Charlot, (b) Topolino. 9.15 (approx.), Dance Music. 10.0, Giornale Radio.

SALZBURG.—See Vienna.

SCHENECTADY

WGY, 790 kc/s, 379.5 metres; 50 kW. Relayed at intervals by W2XAF on 31.48 metres and by W2XAD on 19.56 metres.—12.45 a.m. (Friday), Stock Reports. 1.0 to 3.15, New York Relay. 1.0, Popular Programme. 2.0, Captain Henry's Show Boat. 3.0, Popular Programme, followed by Programme Résumé.

SCHWEIZERISCHER
LANDESSENDER

BEROMUNSTER, 653 kc/s, 459 metres; 60 kW. Basle, 1,229 kc/s, 244.1 metres; and Berne, 1,220 kc/s, 245.9 metres.—5.50 to 6.5 a.m. (from Berne), Gymnastics. 11.0 (from Zürich), Concert by the Small Station Orchestra, conducted by Max Scherbaum. 12.25 p.m. (from Zürich), Time, Weather and Exchange. 12.30 (approx.) to 2.30, Interval. 2.30 (from Zürich), Light Orchestral Concert. 3.0, See Radio Suisse-Romande. 5.0, (from Basle), Songs on Gramophone Records. 5.30 (from Basle), Readings. 6.0 (from Basle), Time, Weather and Traffic Report. 6.10, Concert of Light Music by the Radio Orchestra. 6.40 (from Basle), Talk: Poverty, the Driving Force of Rainer Maria Rilke's Genius. 7.10 (from Basle), Concert of Old English Trio Sonatas. 8.0, Weather and News. 8.10 (from Basle), When the leaves fall. 9.15 (approx.), Close Down.

SOTTENS.—See Radio-Suisse Romande.

STOCKHOLM

689 kc/s, 436 metres; 55 kW. Relayed by Boden, 244 kc/s, 1,229.5 metres; Göteborg, 932 kc/s, 322 metres; Hörby, 1,166 kc/s, 257 metres; Motala, 221.5 kc/s, 1,354.4 metres; Östersund, 389 kc/s, 770 metres; and Sunds-

vall, 554 kc/s, 542 metres.—1.45 p.m., Broadcast for Schools. 4.5, Divine Service from Uppsala, 662 kc/s (453.2 metres). 4.30, Programme for Children. 4.45, Gramophone Music. 5.45, Elementary English Lesson. 6.30, Military Band Concert, conducted by Ivar Widner; Overture, Zampa (Hérold); Selection from La Bohème (Puccini); Two Songs; Valse lente (Merikanto); Selection from The Count of Luxembourg (Lehár); Italian March (Cauzano). 7.15, The Silver Cord—Play. 9.0, Concert of Light Music: Potpourri (Lenschner); Ballet Music from Coppélia (Delibes); Waltz, Mary (Egen); Russian Song (Widen); Spanish Tango (Hyldom); Grieg Potpourri (Urbach). 10.0 (approx.), Close Down.

STRASBOURG

869 kc/s, 345 metres; 11.5 kW.—11.30 a.m., Gramophone Concert: Selection from Rosamund (Schubert); Waltz in A (Brahms); Slav Dance (Dvořák); Petite Suite (Debussy); Ballet Music from Le cid (Massenet); Minuet from Manon (Massenet); Dance of the Sylphs from The Damnation of Faust (Berlioz); Ballet Music from Gretina Green (Guiraud); Ballet Suites from Cydalise et le Chèvre-Pied (Pierné); Valse romantique (Sévère); Overture, Le Roi d'ys (Lalo). 12.45 p.m., News. 1.0, Time. 1.1, Exchange. 1.5, Orchestral Concert, conducted by Maurice de Villers; Overture, The Bartered Bride (Smetana); Symphonic Extracts from The Mastersingers (Wagner); Danse macabre (Saint-Saëns); Fête galante (Lacôme); Hébé (Paul Pierné). 2.0, Programme for Children. 4.0, Light Music on Gramophone Records. 4.45, French Elocution Lesson. 5.0, Orchestral Concert, conducted by Roskam; March (Suppé); Waltz, Amalibis (Scassola); Overture, Der Wildschütz (Lortzing); Potpourri, From Gluck to Wagner (Schreiner); Divertissement (Fili-pucci); Pianoforte Solo; An den Frühling (Grieg); Sous bois (Staub); Selection from Der Obersteiger (Zeller). 6.0, Talk in German: French Civilisation. 6.15, Talk for Women. 6.30, Gramophone Concert. 7.30, Time and News. 7.45, Gramophone Music. 8.0, Press Review in German, Lottery Results and Announcements. 8.30, Literary Programme, relayed from Lyons (La Doua), 644 kc/s, 465.8 metres. 10.30 (approx.), Press Review.

STUTTGART

MUHLACKER, 832 kc/s, 360.5 metres; 60 kW. Relayed by Freiburg, 527 kc/s, 570 metres.—12.35 p.m., Concert of Operetta Music by the Pforzheim Symphony Orchestra, relayed from Pforzheim. Conductor: Hans Leger. March from The Merry Widow (Lehár); Prelude to Eva (Lehár); Selection from Where the Lark sings (Lehár); Waltz, Samt und Seide (Zieher); Rendez-vous bei Lehár (Hrubý). 2.0, Programme for Children. 3.0, See Frankfurt. 5.0, Spanish Lesson. 5.20, Reading (Franz Heinrich Staerk). 5.35, Reading (Walter Luz). 5.50, Time and Announcements. 6.0, Transmission for all German Stations, relayed from Berlin (Funkstunde). 7.0, See Frankfurt. 7.10, See Langenberg. 9.0, See Frankfurt. 9.20, Talk: Things you should know. 9.30, News. 9.45, Concert of Light Music. 10.0, An Unfinished Symphony—Programme arranged by Fritz Gaus. 11.0 till Close Down, See Frankfurt. 12 Midnight (approx.), Close Down.

SUNDSVALL.—See Stockholm.

TOULOUSE

779 kc/s, 385 metres; 8 kW.—6.0 p.m., News. 6.15, Dance Music. 6.30, Popular Songs. 6.45, Extracts from L'Histoire du soldat (Stravinsky). 7.0, Accordion Solos. 7.15, News. 7.30, Songs from Sound Films. 7.45, Music by a Viennese Orchestra. 8.15, Operetta Concert: J'hesite from Enleve-moi (Gaba-roche); Quoi Pippo from La Mascotte (Andran); En cueillant du muguet from Marius à Paris (Mahieux); Chanson du petit bossu from Le petit duc (Lecocq); Ne parlez moi de mon courage from Les Cloches de Corneville (Planquette); Air du rossignol from Les noces de Jeanette (Massé); Selection from Nina Rosa (Romberg); Song from The Merry Widow (Lehár). 8.45, Orchestral Music: Overture, Die Fledermans (Joh. Strauss); Marche joyeuse (Chabrier); Overture, Sicilian Vespers (Verdi). 9.0, Prince Igor—Opera (Borodin)—Concert Version. 9.45, Sponsored Concert. 10.15, North African News. 10.30, Concert for Listeners in Morocco. 11.0, Organ Solos. 11.15, Dance Music. 12 Midnight, News. 12.5 a.m. (Friday), Symphonic Music: Overture, II Seraglio (Mozart); Hurrah! die Musik kommt (Zimmer); Selection from Il Guarany (Gomez); Symphony—The Pacific (Honegger). 12.30 (approx.), Close Down.

TRIESTE

1,211 kc/s, 247.7 metres; 10 kW.—4.10 p.m. till Close Down, See Turin.

TRONDHEIM.—See Oslo.

TURIN

1,096 kc/s, 273.7 metres; 7 kW. Relayed by Milan, 905 kc/s, 331.5 metres; Genoa, 959 kc/s, 312.8 metres; and Florence, 599 kc/s, 500.5 metres.—4.10 p.m., Gramophone Music. 5.0 to 5.5, Weather. 5.40, Giornale Radio, Dopolavoro Announcements and Gramophone Music. 6.0, Time, Tourist Talk and Gramophone Music. 6.10, Agricultural Notes and Wheat Market Report. 6.20, News in Foreign Languages. 6.40, Gramophone Music. 7.0, Announcements, Weather and Gramophone Music. 7.30, Gramophone Concert. 9.0, Police Band Concert, conducted by Marchesini. In the intervals, Talk and Theatre Notes. 10.0, Giornale Radio.

VATICAN CITY

15,120 kc/s, 19.84 metres (Morning) and 5,969 kc/s, 50.26 metres (Evening); 10 kW.—11.0 to 11.15 a.m., Religious Information in French. 8.10 to 8.15 p.m., Religious Information in Italian.

VIENNA

581 kc/s, 517 metres; 100 kW. Relayed by Graz, 852 kc/s, 352.1 metres; Innsbruck, 1,058 kc/s, 283 metres; Klagenfurt, 662 kc/s, 453.2 metres; Linz, 1,220 kc/s, 245.9 metres; and Salzburg, 1,373 kc/s, 218.5 metres.—11.0 a.m., Concert by the Wiener Symphoniker, conducted by Josef Holzer. In the interval at 12 Noon, Time and News. 1.0, Interval. 2.0, Time, Weather, Exchange and Market Prices. 2.20, Talk: Electricity in the Kitchen. 2.30, Programme for Children. 2.55, Italian Opera Music on Gramophone Records: Chorus from The Third Act of La Bohème (Puccini); Quintet from A Masked Ball (Verdi); Duet from Madame Butterfly (Puccini); Sextet from Lucia di Lammermoor (Donizetti); Finale from The First Act of Tosca (Puccini); Duet from Aida (Verdi); Quartet from Rigoletto (Verdi). 3.45, St. Pölten—Talk and Reading. 4.5, Theatre Talk. 4.10, Talk for Women. 4.30, Song Recital by Josefina Stransky (Soprano). 5.10, Talk arranged by the Chamber of Commerce. 5.35, Technical Talk. 6.0, Concert by the Wiener Symphoniker, conducted by Max Schönherr. Soloist: Walter Landauer (Pianoforte); Military March (Schubert); Musik zu einem Waltz, Donaumärschen (Chmel); Phantasielied (Scassola); Suite from Sonnenstrahl (Farkas); Abschiedswalzer (Joh. Strauss); Overture, Ein Opernball (Heuberger). In the interval at 6.35, Time, Weather and Programme Announcements. 7.15, Talk: Gustav Frensen. 7.45, Concert by the Wiener Symphoniker, the Opera House Choir, and Luise Helletsgruber (Soprano): Symphony No. 8 in B minor (Schubert); Lacrimosa from Requiem (Mozart); Finale from The First Act of Loreley (Mendelssohn); Air from Khovanstchina (Mussorgsky); Aria from Turandot (Puccini); Chorus from Manuel Venegas (Wolf); Adagio from the Ninth Symphony in D minor (Bruckner). 9.20, News. 9.35, Gramophone Concert: Overture, Der Waldmeister (Joh. Strauss); Air from Countess Maritza (Kálmán); March from Die Dame mit dem Regenbogen (Gilbert); Old Viennese Melodies (Pollak); Air from Eine Frau, die weiss was sie will (O. Straus); Tango, Du schwarzer Zigeuner (Vacek); Potpourri, Bravo, Bravo (Dostal); Was hat eine Frau von der Treue (Abraham); Slow Foxtrot from Eine Frau, die weiss was sie will (O. Straus); March from White Horse Inn (Benatzky). After the concert, News.

WARSAW

212.5 kc/s, 1,411 metres; 120 kW.—10.57 a.m., Time Signal and Fanfare from St. Mary's Church, Cracow. 11.5, Gramophone Music. 11.30, Radio Journal and Weather. 11.35, Concert by the Philharmonic Orchestra, conducted by Wolfstall, with Introductory Talk. 1.0 p.m., Interval. 2.30, Economic Notes. 2.40, Light Music by the Cyganeria Theatre Orchestra, conducted by Gorzyński. Soloists: St. Gorska (Songs) and Gimpel (Pianoforte). 3.40, Talk for Women. 3.55, Concert of Chamber Music: Sonata in F (Mozart); Sonata in D Minor (Saint-Saëns). 4.50, Agricultural Talk. 5.0, Talk on Economics. 5.20, Light Music on Gramophone Records. 5.40, Programme Announcements. 5.45, Miscellaneous Items. 6.5, Topical Talk. 6.20, Chopin Programme. 7.50, Radio Journal. 8.0, Wireless Talk. 8.15, Concert by the Station Symphony Orchestra, conducted by Oziminski. Soloist: Werminski (Songs). Overture, Fidelio (Beethoven); Serenade for Strings (Haydn); Selection from Tieland (d'Albert); Aria from Fidelio (Beethoven); Mariette's Song from Die tote Stadt (Korn-gold); Ballet Music from William Tell (Rossini); Oriental Suite (Yoshitomo); Japanese Songs (Maklakewicz); Popular Songs (Szopski); Ballet Music from Il Trovatore (Verdi); March (Rapak). In an interval at 9.0, Sports Notes. 9.45, Dance Music from the Adria Café. In the interval at 10.0, Weather and Police Notes.

WILNO

533 kc/s, 563 metres; 16 kW.—6.0 p.m., Programme Announcements. 6.5 till Close Down, See Warsaw.

ZURICH.—See Schweizerischer Landesender.

FRIDAY

OCTOBER THE TWENTIETH

ALGIERS

824 kc/s, 364 metres; 13 kW.—7.0 p.m., Financial Report and Exchange. 7.10, Shipping Notes. 7.15, Agricultural Report and Weather. 7.20, Agricultural Review. 7.35, Concert by a Vocal Quintet. 7.55, News. 8.0, Time Signal. 8.2, Lottery Results. 8.30, Symphony Concert, conducted by Henry Defosse: Symphony, La Reine (Haydn); Selection from *Cydalise et le chèvre-pied* (Fiermé). 8.40, News. 8.45, Gramophone Records. 9.0, Concert (contd.): Prelude and Cortège from *Dejanire* (Saint-Saëns); Clarinet Concerto (Mozart); Suite (Tchaikovsky). 9.30, News. 9.35, Concert by a Cigány Band. 9.55, News.

ATHLONE

725 kc/s, 413 metres; 60 kW. Relayed by Cork. 1,337 kc/s, 224.4 metres.—1.30 to 2.30 p.m., Time, Weather, Stock Report and Gramophone Concert. 6.0, Programme for Children. 6.45, News. 7.0, Gardening Talk. 7.15, Literary and Dramatic Talk. 7.30, Time Signal. 7.31, Operatic Ballad Music by the Station Orchestra. 7.45, Baritone Solos by Leslie Jones. 8.0, The Station Orchestra. 8.15, Tenor Solos by Tony Hughes. 8.30, Variety Programme by the Misses Wickham. 8.50, Mezzo-Soprano Solos by Cecily Kenny. 9.5, The Station Orchestra. 9.30 to 10.30, Programme by the I.B.C. (Ireland) Ltd. 9.30, Concert of Opera Music. Selection from *La Bohème* (Puccini); On with the Motley from *I Pagliacci* (Leoncavallo); Intermezzo from *Cavalleria rusticana* (Mascagni); Tick, Tock, from *The Toy-maker of Nuremberg* (Glass); *Barcarolle* from *The Tales of Hoffman* (Offenbach); O Star of Eve, from *Tannhäuser* (Wagner); Brindisi from *La Traviata* (Verdi); Soldier's Songs (Gungl); Wireless World Announcement. 10.0, Concert arranged by the International Broadcasting Company (Ireland), Ltd.: My Wishing Song (Burke); Maybe I love you too much (Berlin); Puss, Puss, Puss (Hargreaves); Racing Commentary; I'm forgetting myself for you (Meyer); Little Sunshine (Krausz); Mary Rose; I've found a Right Girl (Lupino). 10.30, I.B.C. Good-night Melody, followed by News and Weather. 10.40, Musical Programme. 11.0 (approx.), Close Down.

BARCELONA

EAJ1, 860 kc/s, 348.8 metres; 8 kW.—6.0 p.m., Concert by the Station Trio. 7.0, Request Programme. 7.30, Exchange and Request Programme (contd.). 8.0, Gramophone Music, followed by News. 9.0, Chimes from the Cathedral, Weather, Messages to Seamen, Exchange and Market Prices. 9.10, Concert by the Station Orchestra: March, The Lion (Héliot); Selection from *Maruxa* (Vives); Waltz, Heures d'ivresse (de Bozi and Cools); Variation (Wiltots); Serenade to Colombine (Juel-Fredriksen); Prelude to the Second Act of *El caserío* (Guridi). 10.0, Debussy Programme. 10.30, Dance Music from the Casa Libre. In the interval at 11.0, News. 12 Midnight (approx.), Close Down.

BARI

1,112 kc/s, 269.8 metres; 20 kW.—11.30 a.m. to 3.30 p.m., See Rome. 3.30, Gramophone Records. 3.55 to 5.0. See Rome. 5.0, News in Albanian. 5.45 (approx.) till Close Down, See Rome.

BASLE.—See Schweizerischer Landessender.

BELGRADE

697 kc/s, 430.4 metres; 2.8 kW.—6.0 p.m., Concert by the Radio Orchestra. 7.0, Programme from Zagreb, 977 kc/s, 307 metres. 9.0, Time and News. 9.10 (approx.), Gramophone Music. 9.35, Cigány Music from the Dordjevic Restaurant.

BERLIN

DEUTSCHLANDSENDER, 183.5 kc/s, 1,635 metres 60 kW.—1.0 p.m., Opera and Operetta Music on Gramophone Records: Overture, Oberon (Weber); Introduction to Act III of *Lohengrin* (Wagner); Overture, *Tannhäuser* (Wagner); Song from *Le Postillon de Longjumeau* (Adam); Aria from *Il Trovatore* (Verdi); Selection from *I Pagliacci* (Leoncavallo); Aria from *Cavalleria rusticana* (Mascagni); Overture, *Der Waffenschmied* (Lortzing); Selection from *The Gipsy Baron* (Joh. Strauss); Overture, *Eine Nacht in Venedig* (Joh. Strauss). 2.0, Programme for Girls. 2.30, Weather and Exchange. 2.45, Reading from *Das kaiserbuch* (Paul Ernst). 3.0, See Leipzig. 4.0, Talk: German Heroic Legends. 4.25, Pianoforte and Song Recital by Richard Langs and Margarethe Klose: Pianoforte: Variations on an Old German Love Song (Kuhn); Songs (Rudi Stephan): (a) Kythere, (b) Abendwehen, (c) In Nachbars Garten, (d) Sonntag, (e) Dir, (f) Im Einschlafen, (g) Abendlied, (h) Heimat. 5.0, A Poem. 5.5, Talk: The Skilled Trades through the Centuries. 6.20, Talk: The German Theatre under the New Régime. 5.45, Weather and News. 6.0, Transmission for all German Stations, relayed from Munich. 7.0, Today's Motto. 7.5, The Listeners' Half Hour. 7.30, Das Schweineschlahten—Peasant Comedy (August Hinrichs). 9.0, Weather and News. 9.45, Weather. 10.0, Concert from Hamburg. 11.0 (approx.), Close Down.

BERLIN

FUNKSTUNDE, 715 kc/s, 419.5 metres; 1.5 kW.—5.0 p.m., Talk: Small Pleasures. 5.15, A Visit to a Pianoforte Maker in Luckenwalde. 5.30, The Funkstunde informs its Listeners. 5.45, Topical Talk. 6.0, Transmission for all German Stations, relayed from Munich. 7.5, Dance Music on Gramophone Records. 7.30, Variety Programme by Carola Inlenburg and the Schiwarz-Weiss Players. 8.0, Nature in Contemporary Tone Focus—Concert by the Station Orchestra, conducted by Waldemar von Vultée; *Frühlingsbilder*, Op. 35 (Strauss); *Symphonic Suite*, Die Jahreszeiten, Op. 26 (Unger). 9.0, News. 9.10 (approx.), Concert of Light Music by the Wilfried Krüger Orchestra, relayed from the Traube Restaurant. In an interval at 10.0, Theatre and Film Review. 11.0 (approx.), Close Down.

BERNE.—See Schweizerischer Landessender.

BEROMUNSTER.—See Schweizerischer Landessender.

BODEN.—See Stockholm.

BODO.—See Oslo.

BORDEAUX-LAFAYETTE

986 kc/s, 304 metres; 13 kW.—6.15 p.m., Radio Journal. 7.35, News. 7.40, Educational Programme. 7.55, Lottery Results. 8.0, Spanish Lesson. 8.15, News. 8.30, Concert by the Symphony Orchestra and Soloists.

BRATISLAVA

1,076 kc/s, 279 metres; 14 kW.—5.20 p.m., Humorous Story. 5.35, Gramophone Music. 5.40, Telegraphy Lesson. 5.55, Hints for Housewives. 6.0 till Close Down, See Prague. 9.45 (approx.), Close Down.

BREMEN.—See Hamburg.

BRESLAU

923 kc/s, 325 metres; 60 kW. Relayed by Gleiwitz, 1,184 kc/s, 253 metres.—12 Noon, Weather. 12.5 p.m., Gramophone Concert of Popular Music. 12.45, News. 1.10, Song Recital by Alfred Heimeyer (Bass). Songs (Schumann): (a) *Talismania*, (b) *Auf dem Rhein*, (c) *Freisinn*, (d) *Frühlingssahrt*; Songs (Schubert): (a) *Der Wanderer*, (b) *Aufenthal*, (c) *Prometheus*, (d) *Nachtgesang*. 1.35, Gramophone Records. 2.0, Agricultural Prices. 2.15, Programme for Young People. 3.0, Gramophone Concert. Overture, *The Magic Flute* (Mozart); Selection from *Maritana* (Wallace); *Serenata di baci* (Micheli); *Minuet from the Court of Louis XIV*; *Potpourri* (Puccini); *Duet from Madame Butterfly* (Puccini); *Potpourri*, *Die Welt im Lied* (Intrator); *Waltz from The Arabian Nights* (Joh. Strauss); *Fourth Movement from the Caucasian Suite* (Ippolotov); *Anfang des Sardar*; Overture, *Mignon* (Thomas); *Waltz from Eva* (Lehár); *Paraphrase on Annie Laurie*; *Death of Othello from Othello* (Verdi); *Wedding Day on Troldhaugen* (Greig); *Waltz*, *Leucht-käferin* (E. Strauss); *Intermezzo*, *Roter Mohr* (Siede); *March*, *Alte Soldaten* (Kirsten). 4.45, Agricultural Prices. 4.50 (approx.), Discussion. 5.10, Programme to be announced. 5.35, Talk: The Change in the Silesian Landscape in the Last Seven Centuries. 5.50, Cattle Market Prices. 6.0, Transmission for all German Stations, relayed from Munich. 7.0, News. 7.10, Concert of Folk Dances relayed from the Concert House. 8.30, Radio Report for Workers. 9.0, News. 9.30, Concert from Berlin (Funkstunde). 11.0 (approx.), Close Down.

BRNO

878 kc/s, 342 metres; 35 kW.—5.25 p.m., German Transmission: News, Sports Notes, Topical Talk, Literary Talk and Talk on the Psychology of Animals. 6.0 till Close Down, See Prague. 9.45 (approx.), Close Down.

BRUSSELS (No. 1)

I.N.R., 590 kc/s, 509 metres; 15 kW.—12 Noon, Concert by the Small Station Orchestra, conducted by Leemans. 1.0 p.m., *Le Journal* parlé. 1.10, Gramophone Music. 1.30, *Pendant le bal*—Sketch (Pailleur). 1.50, Gramophone Music (contd.). 5.0, Ganne Concert by the Station Symphony Orchestra, conducted by Kumps. *March*, *Le Père la Victorie*; *Cello Solo*: *Cantilène*; Selection from *Les Saltimbanques*; *Extase*; *Contemplation et pasquinade*; Selection from *Ilans the Flute Player*; *Valse des heures*. 6.0, Talk: The League of Nations and the Colonies. 6.15, Request Gramophone Records. 6.30, Pianoforte Solos by Wilmet: *Italian Concerto* (Bach); *Theme with Variations on the Name A B E G G* (Schumann); *Nocturne in E Flat* (Chopin); *Prelude in A Minor* (Debussy); *Reflets dans l'eau* (Debussy); *Seguidilla* (Albeniz). 7.0, Extracts from *Daphnis et Chloé* (Ravel), on Gramophone Records. 7.15, Talk: Social Service. 7.30, Legal Talk and Literary Review. 8.0,

Concert by the Station Symphony Orchestra, conducted by Kumps. Soloist: Mlle. Denyse Deneumostier (Songs). Overture, *Light Cavalry* (Suppé); Selection from *Die geschienne Frau* (Lehar); *Waltz*, *Acclamations* (Waldteufel); Songs: (a) *Nell* (Faure). (b) *Adieu* (Faure); (c) *Noël des enfants qui n'ont plus de maison* (Debussy); (d) *Pensées d'automne* (Bernart). (e) *Les cheuveux d'or* (Radoux). (f) *Je la Poursuis* (Debaar); *Intermezzo* (van Oost); *La hôte de Pan* (van Oost); *Allegretto* (Daneau); *Scherzo* (d'Agrest). 8.45, Talk: The Parliamentary System and its Possibilities. 9.0, Concert (contd.): Overture, *Phèdre* (Massenet); *La chute des feuilles* (Massenet); *Suite d'Arlequin* (Massenet); *Ballet Music from Lakmé* (Delibes); *Samson and Delilah* (Saint-Saëns), and *Romeo and Juliet* (Gounod). In the interval, Items by Olga Ugane. 10.0, *Le Journal* parlé. 10.10, *La Brabaçonne*.

BRUSSELS (No. 2)

N.I.R., 887 kc/s, 338.2 metres; 15 kW.—Programme in Flemish.—12 Noon, Gramophone Concert. 1.0 p.m., *Journal* parlé. 1.10, Concert by the Small Station Orchestra, conducted by Leemans: *Petite marche viennoise* (Kreisler); *Suite from The Merchant of Venice* (Sullivan); *Valse poudrée* (Popy); Selection from *Paganini* (Lehár); *Violin Solo*: *Slav Serenade* (Doulez); *Andalouse* (De Taeye); Selection from *Le Comte Obligato* (Moretti). 5.0, Concert of Light Music by the Radio Orchestra, conducted by André: *Foxtrot*, *Gin and It* (Parsons); Selection from *Frühling in Wienerwald* (Ascher); *Rumba*, *Palmira* (Simons); *Waltz for Saxophone* (Macker); Selection from *The Student Prince* (Romberg); *Oriental Foxtrot*, *The Persian Caravan* (Benson); *Waltz*, *Dolores* (Waldteufel); *Blues for Trumpet* (Lindley); *One-step* (Wangermée). 6.0, Illustrated Talk on *Mazeppa* (Liszt), *Don Juan* (Richard Strauss), and the *Prelude à l'après-midi d'un faune* (Debussy). 7.0, Concert by the Small Station Orchestra, conducted by Leemans: Overture, *The Cunning Peasant* (Dvorák); *Melody* (Rubinstein); *Flemish Procession* (Leemans); *Dance* (Roels); *Ballet Music from Philémon et Baucis* (Gounod). 7.30, *Journal* parlé. 8.0, Concert by the Radio Orchestra, conducted by André: *Ouverture burlesque* (Méhul); *Extracts from The Fair Maid of Perth* (Bizet); *Jazz in the Zoo* (Basilowsky). 8.30, *Flags on the Matterhorn*—Radio Play (Gasbarra), translated from the German. 9.30, Concert (contd.): *Serenade* (Widor); *Oboe Solo*: *Scènes écossaises* (Godard); *Paysage flamand* (De Taeye). 10.0, *Journal* parlé.

BUCHAREST

761 kc/s, 394 metres; 12 kW.—4.0 p.m., Concert by the Station Orchestra: *March* (Oscheit); *Waltz*, *Ballgeföhster* (Meyer-Helmund); Overture, *Maritana* (Wallace); Selection from *La Gioconda* (Ponchielli); *Foxtrot from Die Fledermaus* (Joh. Strauss-Pochmann); *Serenade* (Klose); *Egyptian Suite* (Thiele); *Suite*, *Un cirque* (Armandola); *Two Intermezzi* (Fétras). In the interval at 5.0, *Radio Journal*. 6.0, Reading. 6.20, Educational Programme. 6.40, *La Traviata*—Opera in Four Acts (Verdi) on Gramophone Records. In the intervals, *Radio Journal*. After the Opera, *Light Music*, relayed from a Restaurant.

BUDAPEST

545 kc/s, 550.5 metres; 18.5 kW.—Also relayed on 840 metres from 6.25 p.m. till Close Down. 1.0 p.m., *Gigli* on Gramophone Records. 3.0, Reading. 4.0, Talk. 4.30, Concert by the Horvath Cigány Band. 5.0, Shorthand Lesson. 5.45, Talk on the following Transmission. 6.30, Relay from the Opera House. In the interval, News. After the Programme, Concert by the Ludwig Veres Cigány Band and the Georg Guttenberg Dance Band, relayed from the Cate Ostend; Soloist: Paul Kaimar (Songs).

COPENHAGEN

1,067 kc/s, 281 metres; 0.75 kW. Relayed by Kalundborg, 260 kc/s, 1,153.8 metres.—11.0 a.m., Time Signal and Chimes from the Town Hall. 11.2, Concert by the Leonard Gyldmark String Ensemble, relayed from the Bellevue Strandhotel. 1.0 p.m., Interval. 1.40, *Pianoforte Recital* by Povl Ingerslev-Jensen: *Bourrée* in B Minor (Bach); *Nocturne in E Flat*, Op. 62, No. 2 (Chopin); *Sonata No. 15 in C* (Mozart). 2.0, Concert by the Teddy Petersen Orchestra, relayed from the Wivex Restaurant. 4.0, Reading (Kristman Gudmundsson). 4.50, Exchange and Fish Market Prices. 4.45, Talk: The History of the Danish Theatre. 5.15, Elementary German Lesson. 5.45, Weather. 5.54, Announcements. 6.0, News. 6.15, Time Signal. 6.30, Talk: Unemployment among Young People. 7.0, Time Signal from the Town Hall. 7.1, Programme by Per

Knutzon. 7.10, *Pianoforte Sonata No. 2 in F* (Mozart) by Folmer Jensen. 7.30, Danish Songs by a Students' Choir, conducted by Johan Hye-Knudsen. 7.55, Sörensen—Radio Play (Jesper Ewald). 8.40, Concert by a Students' Choir, conducted by Johan Hye-Knudsen. 9.0, News. 9.15, Talk. 9.30, Concert by a Balalaika Quintet: *Potpourri of Russian Melodies*; *Romance* (Gluka); *Waltz* (Detlaf); *Barcarolle* (Malov); *Serenade* (Ankarany); *Gipsy Romance*; *Russian Folk Dance*. 10.0, *Dance Music* by the Aage Juhl-Thomsen Band, relayed from the National Scala. In an interval at 11.0, Time Signal and Chimes from the Town Hall. 11.30 (approx.), Close Down.

CORK.—See Athlone.

DANZIG.—See Heilsberg.

DRESDEN.—See Leipzig.

FECAMP

1,328 kc/s, 225.9 metres; 10 kW.—11 a.m. to 12 Noon, Programme in English by the I.B.C. 11.0, Happy Hour. Part I. *Orchestral Concert*. I do like to be beside the seaside (Glover); *The Way to the Heart* (Lincke); *Chorus*, *Your Song of Paradise*; *The Enchanted Forest* (Ganglböger); *Beautiful* (Gillespie); *Chorus*, *Pale Moon*; *The Little Company* (Spain). Part II. *Hawaiian Band*. *The Blue Bird*; *Palikiko Blues*; *Dream Girl of Yesterday*; *In Vienna one Night*; *Manilla Moon*; *Hawaiian Love*; *My South Sea Home*; *Maria Mari*; *Signature Tune*. 12 Noon, Programme in French. 4.30, to 6.0 p.m., Programme in English by the I.B.C. 4.30, *The Nursery Corner*. 5.0, Concert for Southampton and Winchester—Gramophone Records. *Signature Tune*; *Night by the Sea*; *The Grass is gettin' greener all the time*; Selection of *Stephen Foster Melodies*; *Stop the Sun, stop the Moon*; *Gipsy Moon*; *Clarinetitis*; *Brother, can you spare a Dime?* Since you went away; *What aloha means*. 5.30, Concert for Bournemouth and Weymouth. *Light Orchestral Concert*. *Spring Blossoms awaken* (Löhrl); *Pianoforte Solo*, *He wanted Adventure* (Waller); *The Song of the Rose* (McCullough); *When the Convent Bell is ringing* (Trevor); *Viola Solo*: *Oh could I but express in Song*; *Song*, *That's my Home* (Rosing); *My Lady Dainty*; *The Valley of the Poppies* (Ancliffe); *Signature Tune*. 6.0, Programme in French. 10.0 till Close Down, Programme in English by the I.B.C. 10.0, *Signature Tune*, *The Bells of Normandy*; *Lazybones*; *I wish I had Wings*; *Adorable*; *Learn to Croon*; *Oh! Johanna*; *I always keep my Girl out late*; *Sadie the Skater*; *Thank Heaven for you*; *At the Old Pig and Whistle*; *Seven Years with the wrong Woman*; *I can't remember*; *Happy Ending*; *There's a Cabin in the Pines*; *Sergeant Flagg and Sergeant Quirt*; *Drifting down the Shalimar*; *I gotta Right to Sing the Blues*; *Signature Tune*. 11.0, *Talkie Time*. *Signature Tune*, *Sittin' in the Dark*; *Three's a Crowd*; Selection of *Talkie Gems*; *Love me to-night* (Hart); *Heaven will protect an Honest Girl*; *You are my Heart's Delight*, from *The Land of Smiles* (Lehár); *Why has a cow got four legs?*; *The Gold-Digger's Song* (Dubin); Selection from *Love me to-night* (Spolian-sky); *Signature Tune*. 11.30, Club Concert for Tonbridge and Sevenoaks Listeners. Part I. *Orchestral Concert*. *Signature Tune*, *The Chun Song*; *La Czarine* (Ganne); *Song*, *Mountain Lovers* (Squire); *Veleta Medley* (Verney); Selection from *Give me a Ring* (Brookes); *Song*, *Lay your Head on my Shoulder* (Conrad); *Gridiron Club March* (Souza); *Pianoforte Solo*, *When Day is done* (de Sylva); *Pride of the Wolfenines* (Souza). 12.5 a.m. (Saturday). *News*. Bulletin in English. 12.10, Club Concert. Part II. *Cabin in the Cotton*; *Harlem Madness*; *Kalua*; *Wall Street Wail*; *Dancing Time*; *Signature Tune*; *Under a Blanket of Blue*; *You are too Beautiful*; *Let's call it a Day*; *Sweet Dreams*, *pretty Lady*; *Peter, Peter*; *The Old Spinning Wheel*; *Tick, Tock*; *I've got to sing a Torch Song*; *Signature Tune*. 1.0, *Dance Music*. *Signature Tune*, *Bells of Normandy*; *No more Love*; *Maybe I love you too much*; *Pink Elephants*; *Waltzing in a Dream*; *You'll never get up to Heaven that way*; *Sundown in a little Green Hollow*; *Twelfth Street Rag*; *It's Sunday down in Caroline*; *Isn't it heavenly?*; *Reflections in the Water*; *From me to you*; *Hot Feet*; *Love is the Thing*; *Down in the Valley*; *Tick, Tock*; P.C.123. 2.0, I.B.C. Good-night Melody and Close Down.

FLENSBURG.—See Hamburg.

FLORENCE.—See Turin.

FRANKFURT

1,157 kc/s, 259.3 metres; 17 kW. Relayed by Cassel and Trier, 1,157 kc/s, 259.3 metres.—12.15 p.m., Time and News. 12.25, News. 12.35, See Stuttgart. 1.30, Interval. 2.30, Weather. 2.40, Time and Economic Notes. 3.0, See Leipzig. 5.0, See Langenberg. 5.20, Talk: Germany's Racial Types. 5.35, Talk: The Modern Attitude towards Asceticism. 5.50, News. 6.0, Transmission for all German Stations, relayed from Munich. 7.0, Topical Talk. 7.10, See Stuttgart. 9.0, News. 9.20, See Stuttgart. 9.30, News. 9.45, Concert of Light Music. 10.0, Concert by the Station Orchestra, conducted by Reinhold Merten: *Waltz*, *Studentenlust* (Joh. Strauss); *Polka-Mazurka*, *Der Klügere gibt nach* (Joh. Strauss); *Waltz from Donauwiesl*

OCT. 20th **FRIDAY** continued

(Bayer); Risetta Waltz (Lecocq); Polka, Jägerlein (Kozmak); Waltz, Frauenwürde (Joh. Strauss); Waltz, Denksprüche (E. Strauss); Polka, Die Lustigmacherin (Ziehrer); Waltz, Jet' aime (Waldteufel); Waltz, Herbststimmung (Lincke); Gallop, Zeit ist Geld (Lincke). 11.0, Talk: German Thought and German Culture from Goethe to Nietzsche. 11.45 (approx.), Close Down.

FREDRIKSSTAD.—See Oslo.

FREIBURG.—See Stuttgart.

GENEVA.—See Radio-Suisse Romande.

GENOA.—See Turin.

GLEIWITZ.—See Breslau.

GÖTEBORG.—See Stockholm.

GRAZ.—See Vienna.

HAMAR.—See Oslo.

HAMBURG

806 kc/s, 372 metres; 1.5 kW. Relayed by Bremen, 1,112 kc/s, 269.8 metres; Flensburg, 1,319 kc/s, 227.4 metres; Hanover, 530 kc/s, 566 metres; and Kiel, 1,292 kc/s, 232.2 metres.—6.0 p.m., Transmission for all German Stations, relayed from Munich. 7.0, Political Address. 7.10 (from Kiel), Concert of Romantic Music for String Orchestra. The Unemployed Musicians' Orchestra, conducted by Döring. Wanderlied (Kampff); Extracts from Anakreon, Op. 50 (Niemann); Two Bagatelles (Kaua); (a) Moonlight, (b) Minuet; Serenade (Gerlach). 8.10, Vun't bunte Leben—Programme in Dialect, with Music by Hans Frederich Mischeisen. 9.0, Time, Weather and News. 9.20, Concert by the Hamburg Philharmonic Orchestra, conducted by Eibenschütz: Overture, The Bartered Bride (Smetana); Abendlied (Schumann); Träumerei (Schumann); Dance of the Falling Leaves from the Suite, From Finland (Palmgren); Theme and Variations from Suite ancienne (Halvorsen); Selection from the Music to the Pantomime, Der Gaukler und das Klingenspiel (Erdlen); Overture, Der lustige Krieg (Strauss); Selection from The Land of Smiles (Lehár); Waltz, Mon rêve (Waldteufel).

HANOVER.—See Hamburg.

HEILSBURG

1,085 kc/s, 276.5 metres; 60 kW. Relayed by Danzig, 662 kc/s, 453.2 metres.—12.5 p.m., Dance Music on Gramophone Records. In the intervals at 12.20 and 1.0, News. 1.30, Programme arranged by the Post Office, with Gramophone Records. 2.0, Agricultural Prices and Exchange. 2.15, Programme for Children. 2.40, Talk for Women. 3.0, Concert by the Small Station Orchestra, conducted by Eugen Wilken: Overture, The Mikado (Sullivan); Arabian Gold (Rust); Ballet Scene (Armandola); Mon rêve (Waldteufel); Suite, An Evening in Petersburg (Meyer-Helmund); Selection from The Duchess of Chicago (Kálmán); Overture, Der Bajazzo (Czibulka); Suite of Marches (Hufeld); Waltz, Paysage d'automne (Waldteufel); Selection from Drei Wünsche (Ziehrer). In the interval at 3.50 (approx.), Book Review. 4.50, Programme for the Country Woman. 5.15, Agricultural Prices. 5.25, Lieder Recital by Tina Zimmermann-Grassow. Songs (Weber): (a) Die Zeit, (b) Es stürmt auf der Flur, (c) Bach, Echo und Kuss, (d) Das Mädchen an das erste Schneeglöckchen; Songs (Schubert): (a) Wer nie sein Brot mit Tränen ass, (b) Am Grabe Anselms, (c) Wenn über Berge sich der Nebel breitet. 5.50, Weather. 6.0, Transmission for all German Stations, relayed from Munich. 7.0, News. 7.10, Symphony No. 1 in C (Beethoven), by the Königsberg Opera House Orchestra, conducted by Erich Seidler. 7.45, Reading: Wenn die Apfel reif sind (Theodor Storm). 8.0, Concert by the Königsberg Opera House Orchestra, conducted by Wolfgang Brückner: Overture, Waldleben (Kücken); Symphonic Poem, The Mid-day Witch (Dvorak); Bilder aus Osten (Schumann); Waltz, Etincelles (Waldteufel); March, Mit Eichenlaub, und Schwertern (Blon). 9.0, News. 9.20, German Dance Music.

HILVERSUM

1,013 kc/s, 296.1 metres; 7 kW. (up to 5.40 p.m.), and 20 kW. from 5.40 p.m.—11.40 a.m. to 3.40 p.m., Programme of the Allgemeene Vereeniging Radio Omroep (A.V.R.O.). 11.40 a.m., Time Signal. 11.41, Concert of Light Music by Hans Schindler and his Orchestra, with Gramophone Interludes. 1.55 p.m., Gramophone Music. 2.10, Recitations. 2.40, Gramophone Music. 3.40 to 7.40, Programme of the Worker's Radio Society (V.A.R.A.). 3.40, Concert by the Little V.A.R.A. Orchestra, conducted by Hugo de Groot: Gavotte (Lully); German Dances (Beethoven) Minuet (Bocherini); Waltz, Die Schönbirner (Lanner); Waltz, Frauenherz (Jos. Strauss); Trietrac (Waldteufel); Selection from La belle Hélène (Offenbach). Gramophone Music: Muzurka (Ganne); Tango (Albéniz); Mexico (Alex); March (Evans). 4.30, Programme for Children. 5.10, Concert by De Fliedruiters, conducted by van der Horst. 5.42, Song and Organ Recital by Cora de Lange-van Rijn, and Johan Jong. 7.40 to 10.40, Programme of the Liberal Protestant Radio Society (V.P.R.O.). 7.40, Talk. 8.10, Violin and Piano-forte

Recital by Biloen and de Nobel. Violin Solo: Adagio from the Sonata in G Minor No. 1 (Bach); Sonata in B for Violin and Piano-forte (Mozart); Sonata in F, Op. 24 for Violin and Piano-forte (Beethoven). In the interval from 8.40 to 9.10, Talk. 9.40, Religious Report. 9.45, News. 9.55, Talk. 10.25, Gramophone Music. 10.40, Concert of Light Music: Zaragossa (de Gredos) Red Pepper (Lodge); Grüss mir mein Wien (Kálmán); Czardas from The Countess Maritza (Kálmán); Roses of Picardy (Wood); Il torero (Lucchesi); Du bist so wunderschön, Dolores (Valerio). Gramophone Music: Musical Whimsies (Kettelbey); Marechiaré (Tosti); Volga Boat Song from The Czarevitch (Lehár); Argentine Tango (Lucchesi) The Internationale (arr. Geyter). 11.40 (approx.), Close Down.

HORBY.—See Stockholm.

HUIZEN

160 kc/s, 1,875 metres; 7 kW. (until 3.40 p.m.). Transmitted from Kootwijk on 50 kW. from 3.40 p.m.—Programme of the Catholic Radio Society (K.R.O.).—11.55 a.m., Concert by the Vienna Station Octet: March, Freundschaft (Souza); Waltz, Transaktionen (Strauss); Festouvertüre (Leutner); Minuet (Beethoven); Die Wut über den verlorenen Groschen (Beethoven); Italian Suite No. 1 (Bece); Selection from Die Fledermaus (Joh. Strauss); Gramophone Records; Waltz from The Rose of Stamboul (Fall); Aria from Samson and Delilah (Saint-Saëns); Spanish Dance (Schmeling); Viennese Operetta Potpourri (Robrecht); Finale. 1.25 to 1.40 p.m., Interval. 1.40, Gramophone Music. 2.10, Piano-forte Recital by Evert Iluak. 3.10, Concert of Variety Music by the Vienna Station Octet. 4.10, Gramophone Music. 4.40, Concert by the K.R.O. Orchestra, conducted by Geiritsen: Airs de ballet (Rameau); Petite suite (Ducasse); La fille aux cheveux de lin (Debussy); Selection from Hérodiade (Massenet); Prelude to Die Lorelei (Bruch); Selection from Die toten Augen (d'Albert); In the Far West (Bantock); Concert Waltz (Glazunov); Extracts from Scènes napolitaines (Massenet). In the interval at 5.30, Talk: Safety Week. 6.40, Police Notes. 6.55, Geography Talk. 7.15, Gramophone Music. 7.40, The Seasons—Oratorio (Haydn) by the Sursum Corda Choir, The Rotterdam Philharmonic Orchestra and Soloists: Mlle. Sala (Soprano), Plooyer (Tenor), and van Duuren (Bass); Conductor: Van de Putten. In the intervals at 9.25 (approx.), News and Talk, and at 9.55, Gramophone Music. 10.25, News. 10.30, Gramophone Music. 10.40, Popular Music by the Vienna Station Octet. 11.40 (approx.), Close Down.

INNSBRUCK.—See Vienna.

KALUNDBORG.—See Copenhagen.

KIEL.—See Hamburg.

KLAGENFURT.—See Vienna.

KOSICE.—See Prague.

LAHTI

167 kc/s, 1,796 metres; 40 kW. Relayed by Helsinki, 815 kc/s, 368.1 metres.—6.5 p.m., Concert by the Helsinki Municipal Orchestra, conducted by Dr. Helmut Thierfelder, relayed from the University, Helsinki: Overture, Der Freischütz (Weber); Symphony No. 7 (Sibelius); Symphonie brave (Graener); Les Préludes (Liszt). 7.45, News in Finnish. 8.0, News in Swedish.

LANGENBERG

635 kc/s, 473 metres; 60 kW.—12.25 p.m., News and Weather. 12.35, Concert, from Stuttgart. 1.30, Two Talks: (a) Excursions in the Rhineland and Westphalia, (b) Photographic Hints. 1.50, Dance Music on Gramophone Records. 2.10, Reading in Dialect (Räiderscheidt). 2.30, Economic Notes. 2.50, Political Announcements. 3.0, See Leipzig. 5.0, English Lesson. 5.20, Talk on Genealogy. 5.35, Talk: Freiherr von Stein and the Law of Property. 5.50, Announcements. 6.0, Transmission for all German Stations, relayed from Munich. 7.0, See Frankfurt. 7.10, Concert from Stuttgart. 9.0, See Frankfurt. 9.20, See Stuttgart. 9.30, News and Weather. 9.45 till Close Down, See Frankfurt. 11.45 (approx.), Close Down.

LAUSANNE.—See Radio-Suisse Romande.

LEIPZIG

769.9 kc/s, 389.6 metres; 120 kW. Relayed by Dresden, 941 kc/s, 319 metres.—12.30 p.m., Violin and Piano-forte Recital by Hermann Lahl and Friedbert Sammler; Violin and Piano-forte: (a) Waltz (Brahms); (b) Spanish Dance (Manén); Piano-forte Solos: (a) Arioso and Burlesque (Windsparger), (b) Lustiges Stück (Reutter), (c) Allegro ritmico (Haas), (d) Dance (Scott); Violin and Piano-forte: (a) Moment musical (Rachmaninov), (b) The Old Castle (Mussorgsky); Piano-forte Solos (Ebel); (a) Soldatenkom; men, (b) Schlittenfahrt, (c) Slow Waltz; Violin and Piano-forte: (a) Lied (R. Strauss),

(b) Albumblatt (Reger), (c) Hopp-hopp (Schulhoff). 1.15, News. 1.30, Art Review. 1.40, Gramophone Music. 2.0, Economic Review of the Week. 2.15, Programme for the Country Woman. 2.35, Market Prices. 3.0, Concert by the Dresden Philharmonic Orchestra, conducted by Theodor Blumer: Prelude to Hansel and Gretel (Humperdinck); Two Movements from the Serenade in F (Klengel); Polovtsian Dances from Prince Igor (Borodin); Selection from A Masked Ball (Verdi); Symphonic Poem, Orpheus (Liszt); Waltz, Frühlingstimmen (Joh. Strauss); Hungarian Dances Nos. 2 and 7 (Brahms); Peer Gynt Suite No. 1 (Grieg); Overture, Fatinitza (Snppé). 4.50, Economic Notes, Weather and Time. 5.0, Review of Books—Education. 5.20, Talk: False Prophets and Marxists—Deceivers of the People. 5.50, Today's News. 6.0, Transmission for all German Stations, relayed from Munich. 7.0, Czar and Carpenter—Comic Opera (Lortzing). In the interval at 9.0, News. 10.0, Concert by the Station Orchestra, conducted by Hilmar Weber; Soloist, Emil Luh (Violin): Faust Overture (Spohr); Violin Concerto in A Minor, No. 7 (Rode); Scandinavian Suite (Hammerick); Selection from Hansel and Gretel (Humperdinck); Piedmontese Dance in A (Sinigaglia); Selection from The Barber of Seville (Rossini). 11.30 (approx.), Close Down.

LINZ.—See Vienna.

LJUBLJANA

522 kc/s, 574.7 metres; 7 kW.—6.0 p.m., Sokol Lesson. 6.30, Sunday Trips. 7.0, Relay from Zagreb, 977 kc/s, 307 metres. 9.0, Time, News and Dance Music. 10.0 (approx.), Close Down.

LUXEMBOURG

325 kc/s, 1,191 metres; 200 kW. Dutch Programme.—7.0 p.m., Gramophone Records: Symphony No. 5 (Tchaikovsky), by the Amsterdam Concertgebouw Orchestra, conducted by Mengelberg. 7.55, Talk in Dutch. 8.10, Gramophone Records: Spanish Caprice (Rimsky-Korsakov); Suite, Iberia (Debussy). 8.50, News in French. 9.0, Song Recital by Yvonne Pauke: Goodbye; Vorrei morire (Tosti); Cavatina from A Masked Ball (Verdi); Song (Gretchaninov); Der Erlkönig (Schubert); Ungeduld (Schubert). 9.30, Overture, Cockaigne (Elgar), on Gramophone Records. 9.45, News in German. 9.55, Gramophone Music. 10.15, Dance Music on Gramophone Records.

LWOW

788 kc/s, 381 metres; 16 kW.—5.45 p.m., Song Recital. 6.5, Announcements and Gramophone Music. 6.25, See Warsaw. 6.40, Programme Announcements. 6.45, See Warsaw. 10.5, Gramophone Music. 10.30 (approx.), Close Down.

LYONS

LA DOUA, 644 kc/s, 465.8 metres; 1.5 kW.—7.40 a.m., Radio Gazette for Lyons and the South-East. 8.20, Trio Concert: Soloist: Mme. Revellin Thiriet (Songs); Trio (Beethoven); Songs (Fauré): (a) Nocturne, (b) Les Présents; Adagio and Allegro (Haydn); Andante (Koechlin); Tango (Albéniz); Réverie and Serenade (Borodin); Songs: (a) Stances du mortel Sourire (Thiriet), (b) Three Airs from Ce monde de rosée (Delvincourt); Trio (Smetana). After the Concert, News.

MADRID

ARANJUEZ (EAQ), 10,000 kc/s, 30 metres; 20 kW.—10.30 p.m., Concert of Popular Music. In the interval at 10.45, Radio Chronicle. 11.35, Answers to Correspondence. 11.40, Spanish-American Talk. 11.45, Light Music. 12 Midnight till Close Down, Programme in English by the I.B.C. I.B.C. Concert. The Brunette I Love; The Love Lieutenant; The Skaters; Aloha Oe!; Smile, darn yer, Smile; Butterflies in the Rain; Bananas; The Old Blind Man. 12.30 a.m. (Saturday), I.B.C. Good-night Melody.

MADRID

EAJ7, 707 kc/s, 424.3 metres; 2 kW.—7.0 p.m., Chimes, Exchange and Request Gramophone Music. 8.15, Topical Review. 8.30, Interval. 9.30, Chimes, Time, Topical Review. 9.40 (approx.), Tosca—Opera (Puccini), on Gramophone Records—Concert Version. 11.45, Topical Review. 12 Midnight, Chimes and Close Down.

MALMO.—See Stockholm.

MILAN.—See Turin.

MORAVSKA-OSTRAVA

1,137 kc/s, 263.8 metres; 11 kW.—3.0 p.m., Concert by the Station Orchestra, conducted by Plichta. 3.55, See Prague. 5.5, Tourist Report. 5.15 to 9.45, See Prague. 9.45 (approx.), Close Down.

MOSCOW

TRADES UNION, 300 kc/s, 1,000 metres; 100 kW.—10.45 a.m., Weather. 1.45 p.m., Weather Report. 2.0, Extracts from Figaro

—Opera (Mozart). 3.0, Reading from Works on Marxism and Leninism. 3.30, Dramatic Items, followed by Reading from the Poems of Bezymensky and Maiakovsky. 4.30, Concert for Young People. 5.30, Borodin and Ippolitov-Ivanov Concert. 8.0, News. 8.30, Programme Announcements. 8.55, Chimes from the Red Square. 9.5, Press Review. 10.0, Weather.

MOTALA.—See Stockholm.

MUHLACKER.—See Stuttgart.

MUNICH

563 kc/s, 533 metres; 60 kW. Relayed by Augsburg and Kaiserslautern, 536 kc/s, 560 metres; and Nürnberg, 1,256 kc/s, 239 metres.—3.30 p.m., Orchestral Concert, conducted by Erich Kloss: Overture, Im Hochland (Gade); Rhapsody (Kallenberg); Selection from Mona Lisa (Schillings); Karneval - Miniaturen (Kaskel); Mephistos Spiel (Deyer); Eine kleine Liebele (Lautenschlager); Ungarischer Schäferanz (Gungl). In an interval at 4.0, Radio Report on Military Manoeuvres. 4.45, Talk for the Younger Generation. 5.5, Sonata in D minor, Op. 121 (Schumann), for Violin and Piano-forte (Schumann), by Isabella Schmitz (Violin) and Richard Staab (Piano-forte). 5.25, Talk: Eastern Bavaria. 5.45, Time and Announcements. 6.0, Transmission for all German Stations: Three Centuries of Military Marches (arr. Paul Winter) by a Military Band, conducted by Georg Fürst. 7.0, Kimmst auf d'Nacht—Programme in Dialect. 7.45, Political Address. 8.5 (from Nürnberg), Symphony Concert; conductor, Willy Böhm; Soloist, Henry Marteau (Violin); Symphony in C (Wagner); Violin Concerto (Siegfried Wagner). 9.0, Time and News.

NAPLES.—See Rome.

NOTODDEN.—See Oslo.

OSLO

277 kc/s, 1,083 metres; 60 kW. Relayed by Fredriksstad, 815 kc/s, 368.1 metres; Hamar, 522 kc/s, 574.7 metres; Notodden, 671 kc/s, 447.1 metres; Porsgrund, 662 kc/s, 453.2 metres; and Rjukan, 671 kc/s, 447.1 metres.—4.0 p.m., Orchestral Concert, relayed from the Theatre Café; Soloist, Nielsen (Violin): Tartar March (Hürum); Valse caprice (Nordraak); Norwegian Rhapsody No. 1 (Svendsen); Canonetta for Violin (Kleven); Spring (Kristoffersen); Snow (Lie) Violin Solo, Norwegian Dance (Lange); Berceuse (Wingé); March (Grieg). 5.0, French Lesson. 5.30, Talk. 5.0, Announcements. Weather and News. 6.30, English Lesson. 7.0, Time Signal. 7.1, Concert of Sacred Music, relayed from a Church. 7.45, Talk. 8.0, Concert by the Radio Ensemble, relayed from Bergen, 824 kc/s, 364 metres. 8.40, Foreign Market Report, Weather and News. 9.0, Topical Talk. 9.15, Literary Review. 9.45 (approx.), Close Down.

OSTERSUND.—See Stockholm.

PALERMO

558 kc/s, 537.6 metres; 3 kW.—7.0 p.m., Dopplavoro Notes, Tourist Talk, Agricultural Report, Report of the Royal Geographical Society, and Giornale Radio. 7.20, Gramophone Music. In the interval at 7.30, Time and Announcements. 7.45, Concert of Opera Music. In the intervals, Talks and Notes. 10.0, News.

PARIS

POSTE PARISIEN, 914 kc/s, 328.2 metres; 60 kW.—7.0 p.m., Prelude and Variations (Bach) on Gramophone Records. 7.5, Talk. 7.15, Le Journal Parlé. 7.30, Gramophone Music: Charles Panzera: (a) Der Nussbaum (Schumann), (b) L'invitation au voyage (Duparc), (c) Erlkönig (Schubert), Elzabeth Schumann; (d) Freundliche Vision (R. Strauss), (e) Ständchen (R. Strauss), (f) Die Post (Schubert), (g) Wohin (Schubert). 7.50, Talk. 7.55, Agricultural Report. 8.30, Le nouveau Seigneur du village—Opéra-Comique in One Act (Boieldieu), followed by Le Testament de Monsieur de Crauc—Opéra-bouffe in One Act (Lecocq). 10.30, News.

PARIS

RADIO PARIS, Call CFR, 174 kc/s, 1,725 metres; 75 kW.—7.30 a.m., Weather and Physical Culture. 7.45, Gramophone Records: My Rose (Fillis); Isolida (Douce); Seguidillas and Tango (Bautista); Selection from Der Trompeter von Säckingen (Nessler). 8.0, Weather and Press Review. 12 Noon, Programme of Jewish Literature and Music. 12.30 p.m., Gramophone Concert: Ballet Music from The Cid (Massenet); Sicilienne from Cavalleria rusticana (Mascagni); Maundy Thursday in Seville (Turina); Sonata in E (Scarlatini); Waltz in A (Brahms); Der Erlkönig (Schubert); Gretchen am Spinnrad (Schubert); Barcarolle from The Tales of Hoffmann (Offenbach); Valse romantique (Chabrier); Melody from Mirella (Gounod); Serenade (Saint-Saëns); Nocturne from a String Quartet (Borodin); Duet from Romeo and Juliet (Gounod); Trio in G minor (Haydn); Hungarian Rhapsody (Liszt); The Dreary Steppe (Gretchaninov); Etude No. 3 (Chopin); Quintet (Rameau); Piece in C sharp minor (Boulanger); Trio (Poulenc). In the interval at 1.0, Exchange, News and Weather, and at 1.30, Exchange. 2.0, Exchange. 3.45, Exchange and Market Prices. 6.30, Agricultural Talk. 6.50, Insurance

OCT. 20th FRIDAY continued

Societies' Report. 7.0, Talk by Edmond Faloux: The Modern French Novel. 7.20, Parodies and Pastiches—Gramophone Concert: Pianoforte Solo: From Mozart to Hindemith (Lederer); Rhythmic Paraphrase on Verdi's Il Trovatore (Lange); Pianoforte Solo: Impressions of Famous Composers; Pianoforte Quartet: Waltz from Faust (Gounod); Pastiches musicaux (Bétove); Chopinista (Doucet); Wagneria (Doucet); Souvenirs de Bayreuth—Fantasia in Quadrille Form on Themes of Wagner (Fauré-Messager). 7.45, Commercial Prices and News. 8.0, Reading. 8.30, News and Weather. 8.40, Gastronomic Review. 8.45, Madame Butterfly—Opera (Puccini), on Gramophone Records, by the Cast of the Scala, Milan. In the interval at 9.15, Press Review and News.

PITTSBURGH

KDKA, 980 kc/s, 306 metres; 50 kW. Relayed by WXXK on 48.86 metres and 25.27 metres.—7.30 p.m., KDKA Home Forum. 8.0, Programme to be announced. 8.15 to 9.30, New York Relay. 8.15, Utility Hall. 8.30, Words and Music. 8.45, The Morin Sisters. 9.0, Betty and Bob. 9.15, Gene Quaw's Orchestra. 9.30, News and Markets. 9.45, The Arcadians, from New York. 10.0, Uncle Tom and Betty. 10.15, KDKA Kiddies' Klub. 10.30, Singing Lady, from New York. 10.45, Orphan Annie, from New York. 11.0, Press News Reeler. 11.15, Sports, Pat Haley. 11.30, Pittsburgh Spotlights. 11.45, Lowell Thomas, from New York. 12 Midnight, Amos 'n' Andy from New York. 12.15 a.m. (Saturday), Silvertoppers. 12.30 to 3.30, New York Relay. 12.30, Circus Days. 12.45, String Symphony. 1.0, Popular Programme. 1.30, Potash and Perlmutter. 1.45, Red Davis. 2.0, Let's Listen to Harris. 2.30, Popular Programme. 3.0, First Nighter. 3.30, Samuel Di Prinio (Tenor).

PORSGRUND.—See Oslo.

PRAGUE

614 kc/s, 488.6 metres, 120 kW.—3.0 p.m., See Moravská-Ostrava. 3.55, Talk: The Motor Industry and the Crisis. 4.5, Concert by the Prague String Quartet. Quartet in C, No. 19 (Mozart); Quartet in G, Op. 106 (Dvořák). 5.5, Agricultural Prices. 5.15, Talk for Workers. 5.25, News in German. 5.30, German Transmission: Talk on Modern Road Building. 6.0, Time and News. 6.5, English Conversation. 6.20, Introductory Talk to the following transmission. 6.30, The Lantern—Opera (Novak), relayed from the State Opera House. In the intervals at 8.0 and 9.0, Time Signal. 9.15, News, Review of the Day and Sports Notes. 9.30, Talk in Russian. 9.45 (approx.), Close Down.

RADIO-SUISSE ROMANDE

SOTTENS, 743 kc/s, 403 metres; 25 kW., and Geneva, 395 kc/s, 760 metres.—6.0 to 6.15 a.m. (from Lausanne), Gymnastics. 11.28, Time Signal from Neuchâtel Observatory. 11.30, News and Weather. 11.40 (from Geneva), Gramophone Concert. In an interval at 12 Noon, Financial Notes. 1.0 p.m., Interval. 2.58, Time Signal from Neuchâtel Observatory. 3.0 (from Zurich), Concert. 5.0 (from Geneva), Programme for Women. 5.30 (from Geneva), Esperanto Lesson. 5.40 (from Geneva), English Lesson. 6.5 (from Geneva), Talk for Bridge Players. 6.20 (from Geneva), Talk on Chess. 6.35 (from Geneva), Talk. 6.59 (from Geneva), Weather Report. 7.0 (from Geneva), Trio Concert of Modern Music: Sonata for Pianoforte (Durey); Trio (Martini). 7.35 (from Geneva), Recital of Modern Poetry, by Paul Baroz. 7.50 (from Geneva), Synopses for Two Pianofortes. 8.10 (from Geneva), Review of the Week. 8.25 (from Geneva), Concert by the Landwehr, conducted by Hoogstoel. 9.0, News and Weather. 9.10 (from Geneva), Talk: The Work of the League of Nations. 9.30 (approx.), Close Down.

REYKJAVIK

250 kc/s, 1,200 metres; 21 kW.—11.0 a.m., Weather Forecast. 1.15 p.m., Variety Programme. 4.0, Weather Forecast. 8.10, Weather Forecast. 8.20, Light Music and Announcements. 9.0, Light Music. 9.30, Talk. 10.0, Time and News. 10.30, Quartet in B flat (Brahms), played by the Léner String Quartet (on Gramophone Records).

RIGA

572 kc/s, 525 metres; 15 kW.—6.5 p.m., Concert by the Radio Orchestra and the Opera House Orchestra, conducted by Teodors Reiters, relayed from the Opera House. Soloist: Niclas Ojby (Pianoforte). Symphony No. 3 in C (Scriabin); Pianoforte Concerto in F Sharp Minor (Scriabin); Pianoforte Concerto No. 2 in F Minor (Chopin). In the intervals at 6.50, News and at 7.30, News. 8.5, Weather and News. 8.15, Light Music on Gramophone Records.

RJUKAN.—See Oslo.

ROME

Call 190, 680 kc/s, 441 metres; 50 kW. Relayed by Naples, 941 kc/s, 319 metres; Milan (Vigentino), 562 kc/s, 453.2 metres; from 7.15 p.m. (approx.); and 290, 11,810 kc/s, 25.4 metres, from 4.15 p.m.—11.30 a.m., Gramophone Music. 12 Noon, Orchestral Concert of Light Music. In the interval from 12.30 to 12.45, Giornale Radio and Exchange.

1.0, Time and Announcements. 3.30, Children's Radio Review. 3.55, Giornale Radio and Exchange. 4.15 to 5.0, Vocal and Instrumental Concert; Luigi Chiarappa (Cello), Enrichetta Petacci (Pianoforte), Giuseppina Marciano (Soprano), Clara Fioraventi-Cinci (Mezzo-Soprano), and Mario Cavagnis (Tenor): Andante non troppo and Allegro vivo from the Sonata for Cello and Pianoforte, Op. 6 (Richard Strauss); Soprano and Mezzo-Soprano Duets: (a) Song for two Voices (Bellini), (b) Anima mia (da Gagliano); Tenor Solos: (a) Serenade (Beloch), (b) Aria from André Chénier (Giordano), (c) Aria from Manon Lescaut (Puccini); Soprano and Mezzo-Soprano Duets: (a) Folk Song for two Voices, Voglio farti una corona (Bianchini), (b) Duet from Hansel and Gretel (Humperdinck). 5.40 (Naples), Shipping and Sports Notes. 5.45, Dopolavoro and Tourist Report. 5.57, Report of the International Institute of Agriculture (in Spanish, German, and French). 6.10, Wheat Market Report. 6.20, News in Foreign Languages. 6.40, Giornale Radio. 7.0, Time, Announcements, and Sports Notes. 7.15, Sponsored Concert. 8.15, Talk: A Journey in Alaska in a temperature Sixty degrees below zero. 8.30, Police Band Concert, conducted by Marchesini: Overture, Il Guarany (Gomez); Three Songs without Words (Mendelssohn): (a) Spring Song, (b) Spinning Song, (c) The Hunt; Selection from Ero e Leandro (Mancinelli); Humorous Talk; Overture, The Thieving Magpie (Rossini); Serenata abruzzese (de Nardis); Scherzo from L'apprenti sorcier (Dukas); Trumpet Solo, Der Liebespostillon (Neumann); March, Urbs (Marchesini). 10.0, Giornale Radio.

SALZBURG.—See Vienna.

SCHENECTADY

WGY, 790 kc/s, 379.5 metres; 50 kW. Relayed at intervals by W2XAF on 31.48 metres and by W2XAD on 19.56 metres.—7.30 to 8.30 p.m., New York Relay. 7.30, The Romancers. 7.45, Three Shades of Blue. 8.0, Sonata Recital. 8.15, Soloist. 12.45 a.m. (Saturday), Stock Reports. 1.0, Popular Program, from New York. 1.30, Popular Programme. 2.0 to 4.0, New York Relay. 2.0, Popular Programme. 2.30, Dramatic Programme. 3.0, First Nighters. 3.30, Lum and Abner's Friday Night Sociable. 4.0, Programme Résumé.

SCHWEIZERISCHER LANDESSENDER

BEROMUNSTER, 653 kc/s, 459 metres; 60 kW.; Basle, 1,229 kc/s, 244.1 metres; and Berne, 1,220 kc/s, 245.9 metres.—5.50 to 6.5 a.m. (from Berne), Gymnastics. 11.0 (from Basle), Cinema Organ Recital on Gramophone Records. 11.29, Time Signal from Neuchâtel Observatory. Weather and News. 11.40 (from Basle), Extracts from Musical Plays, Operettas and Sound Films, on Gramophone Records. 12.25 p.m. (from Basle), Time, Weather and Exchange. 12.30 (approx.) to 2.30, Interval. 2.30 (from Zurich), Programme for Women. 3.0 (from Zurich), Concert by the Radio Orchestra. 4.0, Gramophone Music. 4.10, Concert by the Small Radio Orchestra, conducted by Scherbaum. 5.0 (from Zurich), Gramophone Music. 5.30 (from Berne), A Dialogue: The Training of Young Farmers. 6.0, (from Berne), Time, Weather, Market Prices, Tourist Talk and Sports Notes. 6.20 (from Berne), Talk: Witchcraft. 6.50 (from Berne), Introductory Talk to the following Transmission. 7.0 I quattro rusteghi—Opera in Three Acts (Wolf-Ferrari). In the interval at 8.0 (approx.), Weather and News. 9.30 (approx.), Close Down.

SOTTENS.—See Radio-Suisse Romande.

STOCKHOLM

689 kc/s, 436 metres; 55 kW. Relayed by Boden, 244 kc/s, 1,229.5 metres; Göteborg, 932 kc/s, 322 metres; Hörby, 1,166 kc/s, 257 metres; Motala, 221.5 kc/s, 1,354.4 metres; Östersund, 389 kc/s, 770 metres; and Sundsvall, 554 kc/s, 542 metres.—12 Noon, Broadcast for Schools. 4.5 p.m., Programme for Children. 4.35, Guitar Music, relayed from Karlstad, 1,382 kc/s, 217 metres. 4.45, Dialogue. 5.0, Gramophone Music. 5.55, Talk on Foreign Politics. 6.30, Talk relayed from Malmö, 1,301 kc/s, 231 metres. 7.0, Orchestral Concert, conducted by Adolf Wiklund; Soloist, Simon Goldberg (Violin); Overture, Romeo and Juliet (Tchaikovsky); Violin Concerto No. 4 in D (Mozart); Pastorale d'été (Honegger); Marche and Gavotte from the Serenade for Small Orchestra (Casella); Poem for Violin and Orchestra (Chausson). 8.15, Talk: Weather. 9.0, Concert: Piece (arr. Söderström); Songs: (a) Anne Marie (Körting), (b) Love's old sweet Song (Molloy), (c) Mattinata (Leoncavallo); Reading: Tarantelle for Flute and Clarinet (Saint-Saëns); Songs: (a) Before you came (Temple King), (b) L'amour, toujours l'amour (Friml); Three Pieces for Quartet. 10.0 (approx.), Close Down.

STRASBOURG

869 kc/s, 345 metres; 11.5 kW.—11.30 a.m., Gramophone Music. Symphony in B (Beethoven); Siegfried Idyll (Wagner); Prelude to Tristan and Isolde (Wagner); Concerto in E flat (Liszt). 12.45 p.m., News. 1.0, Time and Exchange. 1.5, Light Music on Gramophone Records. 2.0, Interval. 4.45, Literary Talk. 5.0, Orchestral Concert, conducted by Roskam. Wien bleibt Wien (Schrammel-Michaelov); Waltz (Fryberg); Plaisir d'amour (Martini); Tango (Michaelov); Foxtrot (Fried and Lombardo); Offenbach Potpourri (Conradi); Foxtrot, My darling (Myers); Brother can you spare a dime? (Conroy); Cello Solo; Réve d'une jeune fille (Vaulet); Waltz, Cuban Love Song (McLugh); Rambling down the Roadway (O'Hagen and Dundas); Spanish March, Merida (Giuliani). 6.0, Trio Concert relayed from Lille, 1,130 kc/s, 265.4 metres. 7.0, Topical Talk in German. 7.15, Talk: The Wines of Alsace. 7.30, Time and News. 7.45, Gramophone Music. 8.0, Press Review in German, Lottery Results and Announcements. 8.30, Songs from Schéhérazade by Mme. Inès Maulejan (Soprano) with Commentary. Three Songs (Lazzari): (a) Demande, (b) Chanson des deux amants, (c) Le passé; Three Songs (Paul Pierné): (a) Berceuse, (b) Une Rose s'effeuille au verger, (c) Les noces; Three Songs (Ravel): (a) Asie, (b) La flûte enchantée, (c) L'indifférent. 9.30 (approx.), Press Review. 9.35 (approx.), Overture to and Act I of Tannhäuser—Opera (Wagner) by the Station Orchestra, conducted by Maurice de Villers. Soloists: Faniard (Tenor) and Mlle. Genya Marat. 10.30 (approx.), Close Down.

STUTTART

MUHLACKER, 832 kc/s, 360.5 metres; 60 kW. Relayed by Freiburg, 527 kc/s, 570 metres.—12.35 p.m., Gramophone Concert. 1.30, Interval. 1.55 (from Mannheim), Suggestions for Sunday Excursions. 2.10, German Chamber Music: Variations for Clarinet and Pianoforte (Weber); Trio No. 4 in B Flat, Op. 11, for Clarinet, Cello and Pianoforte (Beethoven). 2.40, Programme for Children. 3.0, See Leipzig. 4.50, Interval. 5.0 to 5.35, See Langenberg. 5.35, Legal Talk. 5.50, Time and Announcements. 6.0, Transmission for all German Stations, relayed from Munich. 7.0, See Frankfurt. 7.10, Concert by the Württemberg Symphony Orchestra, conducted by Ferdinand Drost, relayed from Heilbronn; Soloists: Adelheid Armhold (Soprano), Heinrich Reikemper (Baritone) and Hermann Hubl (Violin); Symphony in C—the Jupiter (Mozart); Soprano Aria with Violin Obligation from Il re pastore (Mozart); Two Arias from Figaro (Mozart); Overture, Oberon (Weber); Arias from (a) Hans Heiling (Marschner), (b) Der Freischütz (Weber), (c) A Masked Ball (Verdi); Invitation to the Dance (Weber). 9.0, See Frankfurt. 9.20, Talk: Things you should know. . . 9.30, News. 9.45 (from Karlsruhe), Dramatic Programme. 10.0 till Close Down, See Frankfurt 11.45 (approx.), Close Down.

SUNDSVALL.—See Stockholm.

TOULOUSE

779 kc/s, 385 metres; 8 kW.—6.0 p.m., News. 6.15, Music by an Argentine Orchestra. 6.30, Military Music. 6.45, Popular Songs. 7.0, Medical Talk. 7.10, Orchestral Piece: La Valse (Ravel). 7.15, News. 7.30, Accordion Music. 7.45, Operetta Airs. 8.0, Orchestral Concert: Lehár Potpourri (Hrubý); Selection from La princesse jaune (Saint-Saëns); Egyptian Serenade, Anima (Lincke); Ronde villageoise (Chabrier); Minuet in G (Paderewsky); Selection from The Desert Song (Romberg). 8.30, Russian Songs and Balalaika Music. 8.45, Orchestral Pieces. 9.0, Opera and Opéra-Comique Music: Triumphant March from Aida (Verdi); Calumny Aria from The Barber of Seville (Rossini); Aria from William Tell (Rossini); Aria of the Bells from Lakmé (Delibes); Le rêve from Manon (Massenet); Contais-tu le pays from Mignon (Thomas); Prologue to I Pagliacci (Leoncavallo); Aria from Romeo and Juliet (Gounod); Sottly Awakes my Heart from Samson and Delilah (Saint-Saëns); The Miserere Duet from Il Trovatore (Verdi). 9.45, Music by a Viennese Orchestra. 10.0, Light Music. 10.15, North African News. 10.30, Concert for Listeners in Morocco. 11.0, Dance Music. 11.45, Popular Songs. 12 Midnight, News. 12.5 a.m. (Saturday), Opéra-Comique Music: Selection from The Daughter of the Regiment (Donizetti); Overture, The Barber of Seville (Rossini). 12.15, Military Music. 12.30 (approx.), Close Down.

TRIESTE

1,211 kc/s, 247.7 metres; 10 kW.—4.10 p.m., Chamber Music. Roberto Repini-Zoccon (Cello) and Antonio Margella (Bass). Sonata in A Minor (Mareello); Bass Solos: (a) The Prisoner (Grechanirov), (b) The Two Grenadiers (Schumann); Cello Solos: (a) Elegy (Repini-Zoccon), (b) Minuet (Rameau); Bass Solos: (a) Song from Läkns (Delibes),

(b) Aria from Hérodiade (Massenet). 5.0 till Close Down, See Turin.

TRONDHEIM.—See Oslo.

TURIN

1,095 kc/s, 273.7 metres; 7 kW. Relayed by Milan, 905 kc/s, 331.5 metres; Genoa, 959 kc/s, 312.8 metres; and Florence, 599 kc/s, 500.8 metres.—4.10 p.m., Concert of Russian Chamber Music. 5.0 to 5.5, Weather. 5.40, Giornale Radio, Dopolavoro Announcements and Gramophone Music. 6.0, Time, Report of the Royal Geographical Society and Gramophone Music. 6.10, Agricultural Notes and Wheat Market Reports. 6.20, News in Foreign Languages. 6.40, Gramophone Music. 7.0, Announcements, Giornale Radio and Weather. 7.15, Sponsored Music. 7.30, Symphony Music (on Gramophone Records). In the interval: Talk. 9.0, Popular Orchestral Concert, conducted by Tito Petralia. 10.0, Giornale Radio.

VATICAN CITY

15,120 kc/s, 19.24 metres (Morning) and 5,969 kc/s, 50.26 metres (Evening); 10 kW.—11.0 to 11.15 a.m., Religious Information in German. 8.0 to 8.15 p.m., Religious Information in Italian.

VIENNA

581 kc/s, 517 metres; 100 kW. Relayed by Graz, 852 kc/s, 352.1 metres; Innsbruck, 1,058 kc/s, 283 metres; Klagenfurt, 662 kc/s, 453.2 metres; Linz, 1,220 kc/s, 245.9 metres; and Salzburg, 1,373 kc/s, 218.5 metres.—10.30 a.m., Concert by the Wiener Symphoniker, conducted by Josef Holzer. In an interval at 10.55, Weather. 12 Noon, Time and Announcements. 12.10 p.m., Gramophone Concert: Aria from Mignon (Thomas); Hungarian Rhapsody No. 12 (Liszt); Berceuse from Jocelyn (Godard); Aria from Madame Butterfly (Puccini); Death of Othello, from Othello (Verdi); Aria from The Twilight of the Gods (Wagner); Aria from Eugen Onegin (Tchaikovsky); Grave (Bach-Kreisler). 1.0, Interval. 2.0, Time, Weather, and Exchange. 2.20, Gardening Talk. 2.40, Programme for Children. 3.5, Gramophone Concert of Music from Sound Films. 3.30, Programme for Women. 3.55, Talk: Occupations in Old Vienna. 4.20, Sonata in A, Op. 47—The Kreutzer (Beethoven) for Violin and Pianoforte, by Sigmund Feuermann and Otto Schulhof. 4.55, Tourist Report. 5.10, Talk for Women. 5.25, Sports Notes. 5.35, Talk: Art at the Court of the Kings of Benin. 6.0, Concert of Popular Overtures by the Wiener Symphoniker, conducted by Karl Adelheth: The Merry Wives of Windsor (Nicolaï); Si j'étais roi (Adam); Mignon (Thomas); William Tell (Rossini); Der Freischütz (Weber); The Mastersingers (Wagner). In an interval at 6.40, Time and Announcements. 7.5, The Divine Faustina—Play in Eight Scenes (Edmond de Goncourt). 9.0, Announcements. 9.15, Gramophone Concert: Overture, Das Nachtlager von Granada (Kreutzer); Potpourri of German Folk Songs: Paraphrase on the Song, You are my Heart's Delight (Lehar); Waltz from The Flower of Hawaii (Abrahms); Strauss Potpourri (Weber); Old Vienna in Song and Dance (Pachernegg); Foxtrot from White Horse Inn (Stolz-Benatzky); Canzonetta, Tic-Tic, Tic-Ta (Lama); Tango, Mir scheint, du hast geweint (Rosen); Burlesque on Two Bulgarian National Melodies. After the Concert, Announcements.

WARSAW

212.5 kc/s, 1,411 metres; 120 kW.—10.55 a.m., Time Signal and Fanfare from St. Mary's Church, Cracow. 11.5, Quintet Concert. 12 Noon, Interval. 2.30, Economic Notes. 2.40, News. 2.45, Review for Boy Scouts. 2.50, Maritime and Colonial Notes. 2.55, Gramophone Music. 3.40, Review of Publications. 3.55, Song and Pianoforte Recital by Zamorska and Staniewicz. Pianoforte Solos: (a) Fantasia in D minor (Mozart), (b) Danse lente (Frank), (c) Fantasia Impromptu (Chopin) Arias from (a) The Queen of Spades (Tchaikovsky), (b) Hérodiade (Massenet), (c) Zaza (Leoncavallo), (d) Iris (Mascagni); Pianoforte Solos: (a) Le désir (Prokofev), (b) March from Love for the Three Oranges (Prokofev), (c) Prelude (Prokofev), (e) Fire Dance (Falla); Songs: (a) A Tale (Rozycki), (b) The Swan (Szymanowski). 4.50, Agricultural Talk. 5.0, Talk, relayed from Wilno, 533 kc/s, 563 metres. 5.20, Light Music from the Gastro-nomia Restaurant. 6.5, Miscellaneous Items. 6.20, Talk: Excursions for Holidays. 6.25, Topical Talk. 6.40, Programme Announcements. 6.45, Radio Journal. 7.0, Talk on Music. 7.15, Concert by the Philharmonic Orchestra, conducted by Bierdajen. Soloist: Milstein (Violin). Leonora Overture No. 3 (Beethoven); Violin Concerto in D, Op. 61 (Beethoven); Symphony No. 2 (Scriabin); Violin Solos with Pianoforte Accompaniment. In the interval at 8.0, Reading. 9.40, Sports Notes. 9.50, Dance Music from the Adria Café. In the interval at 10.0, Weather and Police Notes.

WILNO

533 kc/s, 563 metres; 16 kW.—6.5 p.m., Topical Talk. 6.20, Miscellaneous Items. 6.25, See Warsaw. 6.40, Programme Announcements. 6.45 till Close Down, See Warsaw.

ZURICH.—See Schweizerischer Landessender.

ALGIERS

824 kc/s, 364 metres; 13 kW.—7.20 p.m., Songs from Sound Films. 7.55, News. 8.0, Time Signal and Lottery Results. 8.10, Concert by the Station Orchestra. 8.40, News. 8.45, Gramophone Music. 8.55, Concert (cont'd.). 9.30, News. 9.35, Accordion Music. 9.55, News.

ATHLONE

725 kc/s, 413 metres; 60 kW. Relayed by Cork, 1,337 kc/s, 224.4 metres.—1.30 to 2.30 p.m., Time Signal, Weather Report, Stock Report and Gramophone Concert. 2.30, Results of the Draw of Hospitals Trust Sweep on the Cambridgeshire. 5.0, Gramophone Music. 6.45, News. 7.0, Aida—Opera in four Acts (Verdi). 9.30 to 10.30, Programme by the I.B.C. (Ireland) Ltd. 9.30, Orchestral Music. Polonaise in A (Chopin); Violin Solo: Hungarian Dance (Brahms); Wireless World Announcement; Invitation to the Waltz (Weber); In the Hall of the Mountain King (Greig). 9.45, Concert of Dance Music. I can't remember (Berlin); Dancing Butterfly (Pelke); The Shadow Waltz (Dubin); Sunny Madeira (Gilbert). 10.0, Concert arranged by the International Broadcasting Company (Ireland), Ltd.: What have we got to lose? (Kent); Shuffle off to Buffalo (Dubin); Jog Along (Arnold); Racing Commentary; In the Park in Páree (Rainger); Pink Elephants (Woodie); Home-made Heaven (Rainger); Waltzing in a Dream (Young). 10.30, I.B.C. Good-night Melody followed by News and Weather. 10.40, Traditional Music. 11.0 (approx.), Close Down.

BARCELONA

EAJ1, 830 kc/s, 348.8 metres; 8 kW.—6.0 p.m., Concert by the Station Trio. Polonaise in B Flat (Schubert); Serenade (Sanderson); Bells across the Meadows (Ketebe); Minuet from the Divertissement in D (Mozart); Selection from Rigoletto (Verdi); Intermezzo (Malvezzi); Selection from Madame Butterfly (Puccini). 7.0, Request Programme. 7.30, Exchange and Request Programme (cont'd.). 8.0, Gramophone Music. 8.15, Anti-War Talk, followed by Request Gramophone Music and News. 9.0, Chimes from the Cathedral. Weather and Exchange. 9.5, Concert by the Station Orchestra. Marcha del progreso (Benhaes); Selection from Ruy Blas (Acevedo); Waltz (E. Strauss); Canzona napolitana (d'Ambrósia); Waltz (Ravel); Novalletta (Claudi); Pizzicato-Caprice (Henley); Overture, Semiramide (Rossini). 10.30, Selection from an Opera on Gramophone Records. In the interval at 11.0, News. 12 Midnight (approx.). Close Down.

BARI

1,112 kc/s, 269.8 metres; 20 kW.—11.30 a.m., Concert by the Radio Quintet. 12 Noon to 3.30 p.m., See Rome. 3.30, Programme for Children. 3.55 (approx.) to 5.0, See Rome. 5.35, News in Albanian. 5.45 to 8.0, See Rome. 8.0, See Turin. 10.0, Giornale Radio from Rome.

BASLE.—See Schweizerischer Landessender.

BELGRADE

697 kc/s, 430.4 metres; 2.8 kW.—6.30 p.m., Folk Song Recital. 7.0, Concert by the Radio Orchestra. 8.0, The Barber of Seville—Opera (Rossini) on Gramophone Records. In the interval at 9.0, Time and News. After the Opera, Dance Music from the Auto Club.

BERLIN

DEUTSCHLANDSENDER (Reichssender), 183.5 kc/s, 1,635 metres; 60 kW.—1.0 p.m., Dance Music on Gramophone Records. 2.0, Handwork Lesson for Children. 2.30, Weather and Exchange. 2.45, Reading from Das kaiserbuch (Paul Ernst). 3.0, See Hamburg. 4.0, Sports Review. 4.20, Künneke and Will Fanta Operetta Music—Recital by Else Kochhammer (Soprano) and Bernhard Bötel (Tenor). 5.0, Poems. 5.5, Radio Report: The Tugs and Small Boats on German Rivers. 5.30, Topical Talk. 5.45, Weather and News. 6.0, Transmission for all German Stations, relayed from Heilsberg. 7.0, Today's Motto. 7.5, Variety Programme in Aid of the Winter Relief Fund. 9.0, News. 9.5 (approx.). Farewell to the Water—Radio Picture (Gustav Schäfer), on Gramophone Records. 9.45, Weather. 10.0, See Langenberg. 11.0 (approx.), Close Down.

BERLIN

FUNKSTUNDE, 715 kc/s, 419.5 metres; 1.5 kW.—3.0 p.m., Concert by the Alfred Brox Orchestra, relayed from the Zoological Gardens. Melody (Micheli); Karneval-Suite (Siede); Liebeserendade (Löhn); Karussell (Kick-Schmidt); Morning, from Peer Gynt (Grieg); Waltz, Lied der Nacht (Kark); Violin Solo: Romance (Svendsen); Intermezzo. Ein Kuss vor Dir (Ailboud); Manchurian Sketches (Glan); Strauss Potpourri (Weber). In an interval at 4.0 (approx.), Talk: Swimming in Winter. 4.35, Weekly Sound News Report. 4.55, Das Hexenlied, Op. 15 (von Schilling), by the Berlin Philharmonic Orchestra, conducted by the Composer (on Gramophone Records). 5.20, Walks in Berlin—An Expedition to the Grünwald. 5.30, The Funkstunde informs its Listeners. 5.45, Topical Talk. 6.0,

Transmission for all German Stations, relayed from Heilsberg. 7.5, Bunter Abend. In the interval at 9.0 (approx.), News, and at 10.0 (approx.), Topical Talk. 12 Midnight (approx.), Close Down.

BERNE.—See Schweizerischer Landessender.

BEROMUNSTER.—See Schweizerischer Landessender.

BODEN.—See Stockholm.

BODO.—See Oslo.

BORDEAUX-LAFAYETTE

986 kc/s, 384 metres; 13 kW.—7.0 p.m., Radio Journal. 7.55, Sports Talk. 8.0, News, Racing Results and Market Prices. 8.5, English Lesson. 8.20, News. 8.30, Gramophone Concert. 9.0, Two Comedies: (a) La fille bien gardée (Labiche and Marc Michel), (b) Le guilloine par persuasion (Eugène Chavette).

BRATISLAVA

1,076 kc/s, 279 metres; 14 kW.—6.0 p.m., See Prague. 9.15, See Brno. 10.30 (approx.), Close Down.

BREMEN.—See Hamburg.

BRESLAU

923 kc/s, 325 metres; 60 kW. Relayed by Gleiwitz, 1,184 kc/s, 253 metres.—12.45 p.m., News. 1.10, Film Review. 1.25, Book Review. 1.45, Talk: The Pleasures of Art. 2.0, Concert. 4.30, Reading (Max Mell). 5.0, Programme Announcements for the Coming Week. 5.10, Programme to be announced. 5.40, Reading of Unfamiliar Rubezahl Legends. 6.0, Transmission for all German Stations, relayed from Heilsberg. 7.0, News. 7.10, Concert of Scandinavian Music by the Silesian Symphony Orchestra, conducted by Rischka; Soloist: Bruno Jagielski (Tenor); Overture, Hamlet (Gade); Three Tenor Solos (Grieg-Rischka): (a) Sommerabend, (b) An Strom, (c) Ein Schwan; Suite No. 5, Baroque (Atterberg); Tenor Solos (Grieg-Rischka): (a) Auf der Reise zur Heimat, (b) Die Prinzessin, (c) Die Johannisnacht; Minuet from the Sonata No. 7 (Grieg); Three Tenor Solos (Grieg-Rischka): (a) Letzter Frühling, (b) Lichte Nacht, (c) An das Vaterland; Suite from the Music to King Christian II (Sibelius). 9.0, News. 9.25, Dance Music relayed from Bad Altheide. 11.30 (approx.), Close Down.

BRNO

878 kc/s, 342 metres; 35 kW.—6.25 p.m., German Transmission; News followed by Slovak, German and Hungarian Folk Songs for Violin and Harpsichord. 6.0, See Prague. 9.15, Concert of Light Music by the Station Orchestra, conducted by Gotthard. 10.30 (approx.), Close Down.

BRUSSELS (No. 1)

I.N.R., 590 kc/s, 509 metres; 15 kW.—12 Noon, Concert by the Small Station Orchestra. 1.0 p.m., Le Journal Parlé. 1.10, Concert by the Radio Orchestra, conducted by Walpot. Soloist: Mme. Armande Bank (Songs). Humorous Ballet Suite (Bianchini); Waltz, Wine, Women and Song (Joh. Strauss); Songs with Orchestral accompaniment. Largo religieux (Armand Crabbé); En sourdine (Crabbé); Violin Solo: Sérénade gracieuse (Collin); Extracts from La Féria (Lacôme). 5.0, Concert by the Station Symphony Orchestra, conducted by Meulemans. Divertissement on Popular Transylvanian Themes (Samuel); Cello and Orchestra: Berceuse (Absil); En forme de menuet (Jongen); Oboe and Pianoforte Concerto (Robert); Alméria (Mahy); Meditation (Rasse); Waltz from the Ballet, Hoppes et Hoppes (Lauweryns); Menuet de printemps (Desprez); Kermesse en Brabant (Sarly). 6.0, Talk: Chartered Accountancy. 6.15, Gramophone Music. 6.30, Chopin Pianoforte Music. Fantasia, Op. 49 Polonaise, Op. 71, No. 2. 6.45, Gramophone Music. Norwegian Dances (Grieg); Ballet Music from Isoline (Messenger). 7.15, Recital of the Music of Abel Nathan. 7.30, Le Journal Parlé. 8.0, Chamber Music by the Liège Quartet. Quartet No. 15 (Mozart); Quartet, Op. 41, No. 1 (Schumann). 8.45, Scenes from Molière's Plays, with Commentary: Tartuffe, L'Avare, Le Malade imaginaire, and Le dépit amoureux. 10.0, Le Journal Parlé.

BRUSSELS (No. 2)

I.N.R., 887 kc/s, 338.2 metres; 15 kW.—Programme in Flemish.—12 Noon, Concert by the Radio Orchestra, conducted by Walpot. Soloist: Armande Bank (Songs); March of the Marionettes (Hullebroeck); Waltz from Faust (Gounod); Overture, Czar and Carpenter (Lortzing); Petite culine (Gillet); Lontanetta (Razigude); Italian Songs: Hungarian Rhapsody, No. 2 (Liszt); Vibraphone Solo: Tango, Wenn es Bestimmung ist (Ro-

land); Extracts from the Esquisses flamandes (Brusselmans). 1.0 p.m., Journal Parlé. 1.10, Concert by the Small Station Orchestra, conducted by Leemans. Overture, Maritana (Wallace); Liebestraum (Liszt); Serenade, Granada (Albeniz); Selection from La Traviata (Verdi); Nocturne for Violin (Chopin-Sarasate); Ballet Music from Faust (Gounod); Kiss Waltz (Burke); Foxtrot, Fascinat' Vamp (Nussbaum). 4.45, Reading. 5.0, Concert by the Radio Orchestra, conducted by Walpot. Motor March (Rosey); Overture, Fra Diavolo (Auber); Waltz from Moulins qui chantent (Van Oost); Selection from Carmen (Bizet); La voix des cloches (Luigini); Gracious Dolly (Macker); Rumba (Crabbé); Ballet Music from the Queen of Sheba (Gounod). 6.0, Gramophone Music. Sonata in A (Mozart-Tertis); Toccata from the Fifth Symphony (Widor). 6.15, Readings with Commentary. 6.30, Concert by the Small Station Orchestra conducted by Leemans. Carmen Festivum (Gillon); Paysage flamand (De Taeve); Aubade à Kiki (De Boeck); Ballet Music from Henry VII (Saint-Saëns); Impromptu for Pianoforte (Brenta); Hornpipe (O'Neil); Selection from Piccolino (Giraud); Ballet Suite (Poppy). 7.15, Talk: Artistic Tendencies in Children. 7.30, Agricultural Review. 8.0, Francesca—Opera in Five Acts (De Boeck), relayed from the Royal Opera House, Antwerp. In the intervals at 8.34 and 9.13, Humorous Items, and at 10.0 and 10.20, Gramophone Music. 10.48 (approx.), Close Down.

BUCHAREST

761 kc/s, 394 metres; 12 kW.—4.0 p.m., Jazz Music. 5.0, Radio Journal. 5.15, Jazz Music (cont'd.). 6.0, Educational Programme. 6.20, Song Recital. 6.40, Talk. 7.0, Russian Song Recital by Xenov. 7.20, Choral Music relayed from the Silvestre Church. 8.0, Talk. 8.15, Pianoforte Recital of Jazz Music by Sibiceano. 8.45, Radio Journal. 9.0, Light Music, relayed from a Restaurant.

BUDAPEST

545 kc/s, 550.5 metres; 18.5 kW.—Programme also relayed on 840 metres.—4.30 p.m., Concert by the Concert Orchestra, conducted by Viktor Vaszy. 5.45, Programme for Workers. 6.15, Concert by the Municipal Choir. 7.0, Anna Bal—Operetta in Three Acts (Martos and Vihce). Conductor: Vincze. 9.15, News. 9.30 (approx.), Gramophone Concert.

CASSEL.—See Frankfurt.

COPENHAGEN

1,067 kc/s, 281 metres; 0.75 kW. Relayed by Kalundborg, 260 kc/s, 1,153.8 metres.—11.0 a.m., Time and Chimes from the Town Hall. 11.2, Concert by the Bendix String Ensemble, relayed from the Wivex Restaurant. 1.0 p.m., Interval. 2.0, Gramophone Concert. 2.30, Concert by the Radio Orchestra, conducted by Emil Reesen. Soloist: Lis Jacobsen (Songs). Concert Overture, Ruy Blas (Mendelssohn); Prelude (Jørgensen); Salut de printemps (Jørgensen); Selection from The Barber of Seville (Rossini); Romanian Waltz, Sylva (Spacek); Five Songs with Pianoforte Accompaniment (Lange-Müller); Overture, The Bohemian Girl (Balfe); Ballet Music from La belle Hélène (Offenbach); Three Pieces (Dvorak): (a) Waltz in A, (b) Humoresque, (c) Slav Dance in C; Battle March (Müller). 4.30, Exchange and Fish Market Prices. 4.45, Talk. 5.15, French Lesson. 5.45, Weather. 5.54, Announcements. 6.0, News. 6.15, Time Signal. 6.30, The History of Music—The Transition of the Viennese Masters. 7.0, Talk by Knud Jeppesen and Concert by the Radio Orchestra, conducted by Launy Grøndahl. Soloist: Folmer Jensen (Harpichord). Sinfonia (Wagebsen); Harpsichord Concerto in E Flat (J. C. Bach); Sinfonia (Stamitz). In the interval at 7.0, Chimes from the Town Hall. 7.40, A visit with the Microphone to a Sugar Factory. 8.10, Dance Music by the Vilfred Kjaers Rhythm Orchestra, the Rhythm Girls, a Quartet and Soloists. Orchestra: (a) Selection from Forty Second Street (Dublin and Warren). (b) I cover the Waterfront (Green and Heymann), (c) Something came and got me in the Spring (Scholl, Schwartz and Rich); Rhythm Girls: Selection from the Jazz Oratorio (Christensen). Trumpet Solos: (a) Minnie the Moocher (b) Blues, (c) Stomp; Orchestral Foxtrot, Sluffe off to Buffalo (Dubin and Warren); Quartet: (a) Four String Joe (Venuti), (b) Egen Komposition, (c) Ducky Wucky (Elington); Songs: (a) Creole Love Call (Elington), (b) Valse Marilyn (Wiedoeft); Violin Solos: (a) It aint no Fault of Mine (Davis Williams), (b) Foxtrot, (c) Waltz, (d) Quickstep; Orchestra: Dixieland One-step. In the interval, Recitation. The Comedian Harmonists. 9.25, News. 9.40, Gramophone Records. 9.55, Dance Music.

In an interval at 11.0, Time Signal and Chimes from the Town Hall. 11.15 (approx.), Close Down.

CORK.—See Athlone.

DANZIG.—See Heilsberg.

DRESDEN.—See Leipzig.

FECAMP

1,328 kc/s, 225.9 metres; 10 kW.—11.0 a.m. to 12 Noon, Programme in English by the I.B.C. Happy Hour. Part I: Trio Concert: Signature Tune, Narcissus (Nevin); Un peu d'amour (Silesu); Violin Solo: The Song of Songs (Moya); Pizzicato from Sylvia (Delibes); Friend o' Mine (Sanderson); Chorus: Somewhere a voice is calling (Tate); Toreador and Andalous (Rubinstein); Pearl of Mine (Fletcher). Part II: Dance Music: Let's all be happy together; Down in the Valley; My Lucky Day; In memory of you; Avalon; I wish I had Wings; Dancing to save your sole; Nobody's Sweetheart; Signature Tune. 12 Noon, Programme in French. 4.30 to 6.0 p.m., Programme in English by the I.B.C. 4.30, The Nursery Corner. 5.0, Military Band Concert for Tunbridge Wells and Isle of Thanet: Signature Tune, The Night by the Sea; Selection from The Vagabond King (Friml); Jungle Drums (Ketebe); Squirrel Dance (Elliott-Smith); Fighting Mac (Traditional); On the Quarter Deck (Alford); Brabazon (Dunn); In a Monastery Garden (Ketebe); The Changing of the Guard. 5.30, Orchestral Concert for Dover and Folkestone: By the Swanee River (Myddleton); Song, The Company Sergeant-Major (Sanderson); Under Heaven's Blue (Payan); Song, Le Réve passe (Krier); Song, In Sheltered Vale (Clarke); Spanish Serenade (Herbert); Chinese Serenade (Herbert); Selection from Wiener Blut (Strauss); By the Sleepy Lagoon (Coates); Signature Tune. 6.0, Programme in French. 11.0 till Close Down, Programme in English by the I.B.C. 11.0, Talkie Time: Signature Tune, Sittin' in the Dark; There's Magic in the Air (Byton); Mrs. Bartholomew (Ellis); City Lights; Why has a Cow got four legs? (Ellis); Selection, The Crooner; Sweetheart Darlin' (Stophart); Talking to you about me (Snyder); Lady Divine (Kountz); Signature Tune. 11.30, Concert by the International Broadcasting Company (Ireland), Ltd.: Signature Tune, Come back to Erin; Invitation to the Waltz (Weber); Cello Solo: Harlequinade (Squire); Biddy Mulligan (Kavanagh); Idylle bretonne (Gemin); Love Serenade (Blon); Coal Black Mammy (Cliff); Ay, Ay, Ay (Friere). Selection from Die Fledermaus (Strauss); Signature Tune, Come back to Erin. 12.5 a.m. (Sunday), Late News Bulletin in English. 12.10 (approx.), Club Concert for Maidstone Listeners: Signature Tune, The Chum Song; I wanna count sheep (Young); Mamita Perdon (Villamonte); I'm telling the world she's mine (Maurice); Sophisticated Lady (Elington); Oh, you sweet thing (Hines); Sweet Dreams Pretty Lady (Downey); Carry me back to Green, Green Pastures (Pepper); A Girl like Nina (Hammerstein); Lazybones (Mercer); Wedding of the Dragonflies (Myers); In the Park in Páree (Rainger); Come out Vienna (Herbert); Little Miss Muffett (Perritt); Learn to Croon (Coslow); Signature Tune. 1.0, Dance Music: Signature Tune, Bells of Normandy; It's Sunday down in Caroline; At the Old Pig and Whistle; I wanna count sheep; Hold me; Seven years with the wrong woman; Dance Pretty Lady; It was a night in June; Reflections in the Water; Under a Blanket of Blue; Avalon; Down in the Valley; Waltzing in a Dream; I sigh for you, Rio Rita; Tick, Tock; Hobo, you can't ride this Train; Isn't it Heavenly; Signature Tune. 2.0, I.B.C. Good-night Melody and Close Down.

FLensburg.—See Hamburg.

FLORENCE.—See Turin.

FRANKFURT

1,157 kc/s, 259.3 metres; 17 kW. Relayed by Cassel and Trier, 1,157 kc/s, 259.3 metres.—12.15 p.m., Time and News. 12.25, Local News and Weather. 12.35, See Langenberg. 1.30 to 2.30, See Stuttgart. 2.30, Weather. 2.40, Time and Economic Notes. 3.0, See Stuttgart. 5.0, Talk: The Frontier Question. 5.20, Review of the Week. 5.35, Programme to be announced. 5.50, News. 6.0, Transmission for all German Stations, relayed from Heilsberg. 7.0, Topical Talk. 7.10, Bunter Abend. 9.0, News. 9.20, See Stuttgart. 9.30, News. 9.45, See Stuttgart. 10.0 till Close Down, See Langenberg. 1.0 a.m. (Sunday), Close Down.

FREDBIKSTAD.—See Oslo.

FREIBURG.—See Stuttgart.

GENEVA.—See Radio-Suisse Romande.

GENOA.—See Turin.

GLEIWITZ.—See Breslau.

GOTEBERG.—See Stockholm.

GRAZ.—See Vienna.

HAMAR.—See Oslo.

HAMBURG

805 kc/s, 372 metres; 1.5 kW.—Relayed by Bramen, 1,112 kc/s, 269.8 metres; Flensburg, 1,319 kc/s, 227.4 metres; Hanover, 530

OCT. 21st **SATURDAY** continued

kc/s, 566 metres; and Kiel, 1,292 kc/s, 232.2 metres.—3.0 p.m., Orchestra Concert, conducted by José Eibenschütz. A Festival Overture (Wagner); Two Pieces (Grieg): (a) Herzwunden, (b) An den Frühling; Selection from Aida (Verdi); Wedding Waltz from The Veil of Pierrette (Dohnanyi); Selection from Schön ist die Welt (Lehar). 4.0, Topical Programme. 4.30, Variety Programme. 5.35 (from Kiel), Religious Address. 5.50, Weather. 6.0, Transmission for all German Stations, relayed from Heilsberg. 7.0, Bunter Abend. In the interval from 9.0 to 9.30, News. 11.0 (approx.), Close Down.

HANOVER.—See Hamburg.

HEILSBURG

1,085 kc/s, 276.5 metres; 60 kW. Relayed by Danzig, 662 kc/s, 453.2 metres.—10.30 a.m. (from Danzig), Concert by the Danzig Police Band, conducted by Ernst Stiebertz; Overture, Im Reiche des Indra (Lincke); Egyptian March (Jos. Strauss); Selection from Drei alte Schachteln (Kollo); Liebestraum-Walzer (Chopin); March from Fatimiza (Suppé); Selection from The Little Dutch Girl (Kálmán); Zigennerleben (Schumann); Waltz, Sommerabend am Rhein (Ziehrer); Gavotte, Blümlen Vergissmännchen (Giese); March, Bona Fortuna (J. F. Wagner). 12.5 p.m., Gramophone Concert. In the intervals at 12.20 and 1.0, News. 1.30, Programme arranged by the Post Office with Gramophone Records. 2.0, Agricultural Prices and Exchange. 2.30, Handwork for Children. 3.0, Concert. In an interval at 3.50, A.D.A.C. Traffic Report. 4.50, Discussion on Road Accidents. 5.5, Forthcoming Programme Events. 5.15, Agricultural Prices. 5.25, Organ Recital by Traugott Fedtke: Organ Concerto No. 8 in A (Händel); Partita on the Choral, Jesu meine Freude (Walter). 5.50, Weather. 6.0, Transmission for all German Stations: East Prussian Songs and Dances (arr. Rudolf Kaestner). 7.0, News. 7.10, Bunter Abend, relayed from the Town Hall, Königsberg. 9.10, News. 9.20 (approx.), Variety from Berlin (Funkstunde). 11.30 (approx.), Close Down.

HILVERSUM

1,013 kc/s, 296.1 metres; 7 kW. up to 5.40 p.m., and 20 kW. from 5.40 p.m.—11.40 a.m. till Close Down, Programme by the Workers Radio Society (V.A.R.A.). 11.40 Orchestral Concert, conducted by Wims: Smokey nokes (Holzmann); Wiener Praterleben (Translatour); Andante and Scherzo (de Michel); Romance (Messenger); Spanish Rhapsody (Richard); Dornröschens Brautfahrt (Rhoda); Gramophone Records, Venetian Serenade (Fouadain); Serenade (Rachmaninov); Fest der Zwerge (Kockert); Phantom Melody (Ketelbey); Spanish Dance (Moszkovsky); Melody (Rhode). 12.55 p.m., Gramophone Music. 1.40, Interval. 1.56, Gramophone Music. 2.30, Talk. 2.40, Concert by the Amsterdam Symphony Orchestra, conducted by Smit: In New York Style (Howard); Berlin wie es weint und lacht (Couradi); Air (Erti); Backfischen Parade (Lincke); Selection from Il Trovatore (Verdi); Folk Melody (Frederiksen); The Cockchafers' Tea Party (Noack). 3.40, Recital by Weissbach (Tenor); and Slevin (Organ and Pianoforte). 4.10, Film Talk. 4.30, Orchestra Concert (contd.): Waltz Potpourri (Rohrecht); May Song (de Michel); De verjaardag van Piet de Smeerpoots (Bettecke); Lotosblumen (Ohlsen); Lockenköpfchen (Eilenberg); Wiener Spaziergänge (Konjak). 5.5, Gramophone Music. 5.10, Literary Talk. 5.42, Choral Concert. 6.10, Talk on Music with Illustrations. 6.40, Talk. 7.10, Gramophone Music. 7.40, 808 Messages. 7.42, Press Review and Announcements. 7.55, Orchestral Concert, conducted by De Groot: Soloists: Mlle. Sala (Soprano) and Wigelaar (Violin), de Klijn (Violin), and Wims (Pianoforte): Overture, Il Seraglio (Mozart); Soprano Aria from Il Re pastore (Mozart); Two Slav Dances (Dvorák); Havaneise for Violin and Orchestra (Saint-Saëns); Soprano Aria from Madame Butterfly (Puccini); Overture, Mignon (Thomas); Mock Morris (Grainger); Shepherd's Hey (Grainger); Rhapsody in Blue (Gershwin). 8.55, Talk. 9.5, Organ Recital by Jong. 9.25, Recitations. 9.45, Concert by De Flierefluiters, conducted by van der Horst with Song Refrains by de Booy. 10.40, Gramophone Music. 11.40 (approx.), Close Down.

HORBY.—See Stockholm.

HUIZEN

160 kc/s, 1,875 metres; 7 kW. until 3.40 p.m. Transmitted from Kootwijk on 50 kW. from 3.40 p.m.—Programme by the Catholic Radio Society (K.R.O.). 11.55 a.m., Concert by the Vienna Station Octet. Radetzky March (Strauss); Troika (Bottaro); Overture to an Operetta (Suppé); Serenade (Widor); Spanish Dance No. 2 (Moszkovsky); Ballet Music from Sylvia (Delibes-Weingier); Jalonsie (Gade); Gramophone Records; Selection from The Czarevitch (Lehar); Minuet (Paderewsky); Ruminische Liebesnacht (Köping); Hungarian Dances Nos. 5 and 6 (Brahms); Finale. 1.25 p.m., Interval. 1.40, Programme for Young People. 2.10, Programme for Children. 3.40, Concert by the

K.R.O. Orchestra, conducted by van 't Woud. Dem Lenz entgegen (Blankenburg). Overture, Casanova (Lincke); In a Fairy Realm (Ketelbey); Waltz, Roses from the South (Strauss); Selection from The Duchess of Chicago (Kálmán); Overture, Indigo (Strauss); Potpourri, Musical Soap-bubbles (Urbach); In the Harbour of Port Said (Armandola); An Evening in St. Petersburg (Helmund); Tritsch-Tratsch (Strauss); Selection from The Dollar Princess. In the intervals at 4.10, Talk on Writing, at 4.55, News in Esperanto and at 6.0, Press Review. 6.40, Police Notes. 6.55, Talk. 7.15, Gramophone Music. 7.25, Sports Talk. 7.40, Concert by the K.R.O. Boys. 8.10, News. 8.15, Gramophone Music. 8.40, Wie is de Moordenaar (Who is the Murderer?)—Play in Three Acts (Hollander). 9.25, Concert by the K.R.O. Boys. 9.55, Variety Programme on Gramophone Records. In the interval at 10.10, News. 10.30, Concert by the K.R.O. Boys (contd.). 11.40, (approx.), Close Down.

INNSBRUCK.—See Vienna.

KALUNDBORG.—See Copenhagen.

KIEL.—See Hamburg.

KLAGENFURT.—See Vienna.

KOSICE.—See Prague.

LAHTI

167 kc/s, 1,796 metres; 40 kW. Relayed by Helsinki, 815 kc/s, 368.1 metres.—5.35 p.m., Finnish Festival Programme. 7.45, News in Finnish. 8.0, News in Swedish. 8.15, Dance Music from the Pörssi Restaurant.

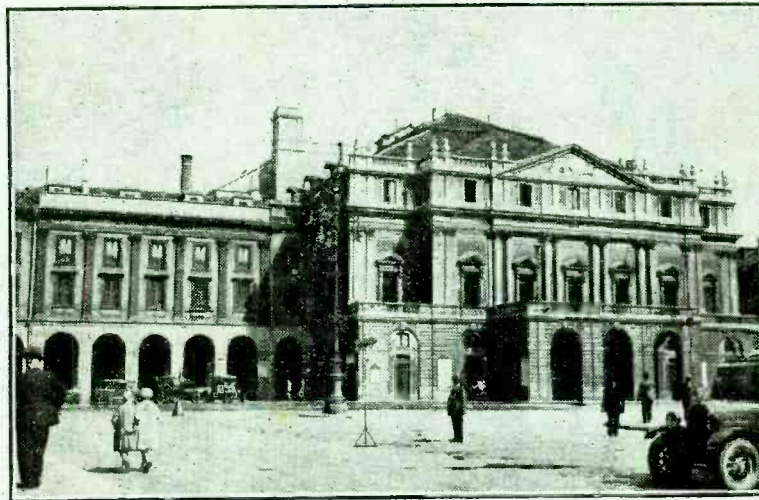

A "La Scala Opera" night at Milan is always something worth waiting for. Here is a front view of the Scala, probably the most famous opera house in the world.

LANGENBERG

635 kc/s, 473 metres; 60 kW.—12.35 p.m., Concert by the Small Münster Orchestra, conducted by Werner Göhre: Overture, Raymond (Thomas); Waltz (Debussy); Serenade (Albeniz); Selection from Si j'étais roi (Adam); A Wedding Day on Troidhangen (Grieg); Selection from The Gipsy Baron (Joh. Strauss). 1.30, See Stuttgart. 2.30, Economic Notes. 2.45, Programme for Young People. 3.0, See Stuttgart. 5.0 to 5.35, See Frankfurt. 5.35, Musical Programme. 5.50, Announcements. 6.0, Transmission for all German Stations, relayed from Heilsberg. 7.0 to 9.20, See Frankfurt. 9.20, See Stuttgart. 9.30, News and Weather. 9.40, An Old People's Festival Evening, relayed from the Solingen Town Hall. 10.0, Cabaret Programme, conducted by Baumgartner. 12 Midnight, Gramophone Concert of German Opera Music: Overture and Two Arias from The Barber of Bagdad (Cornelius); Overture and Agatha's Aria from Der Freischütz (Weber); Chorus and Two Quartets from Fidelio (Beethoven); Overture, Tannhäuser (Wagner).

LAUSANNE.—See Radio-Suisse Romande.

LEIPZIG

769.9 kc/s, 389.6 metres; 120 kW. Relayed by Dresden, 941 kc/s, 319 metres.—12.35 p.m., See Langenberg. 1.30, News. 1.45, Programme for Children. 2.30, Book Review. 2.45, Economic Notes and News. 3.0, Concert relayed from Berlin (Funkstunde). 4.0, Talk: The Experiences of Six Young People travelling through Holland. 4.20, A

Modern Dictionary. 4.30, Talk. 4.50, Reading of Ballads (Kurt Geucko). 5.0, Dances from Eighteenth Century Viennese Masques—The Emdé Orchestra conducted by Heinrich Werlé and Soloists. 5.50, To-day's News. 6.0, Transmission for all German Stations, relayed from Heilsberg. 7.0 (from Dresden), Concert of Operetta Music by the Dresden Philharmonic Orchestra, conducted by Ernst Schicketanz and Soloists: Overture, Carnival in Rome (Joh. Strauss); Soprano Solo: Song to the Virgin Mary (Genée); Flüster-quartett from Der Seekadet (Genée); March from Fatimiza (Suppé); Tenor Solo from Der Göttergatte (Lehar); Two Tenor Solos (Schicketanz): (a) Klein Mädchen, (b) Ich bin ein Student; Trio from Der Vizeadmiral (Millöcker); Pizzicato Polka (Jos. Strauss); Baritone Solo from Chansonnette (Dellinger); Duet (Müller); Tenor Solo and Duet from Der Vizeadmiral (Millöcker); Waltz, Wo die Zitronen blüh'n (Strauss); Overture, Der Waldmeister (Joh. Strauss); Baritone Solo: Ballad (Müller); Duet from Saint Cyr (Dellinger); Tenor Solos: (a) Song from Das süsse Mädel (Reinhardt), (b) Couplet from Chansonnette (Dellinger); Polka (Jos. Strauss); Tenor Solos: (a) Wann i a Musik hir' (Schicketanz), (b) Song from Sonntagskind (Millöcker); Soprano Solo from Boccaccio (Suppé); Tenor Solos: (a) Volga Song from The Czarevitch (Lehar), (b) Rasch verfliegt Soldatenliebe (Müller); Duet, Bei mir ist morgen Schutzenfest (Schicketanz); Quartet from Frühlingsluft (Jos. Strauss-Reiterer); Florentine March (Fucik). In the interval at 9.0, News. 10.0, Dance Music

by the Emdé Orchestra. 11.0 (approx.), Close Down.

LINZ.—See Vienna.

LJUBLJANA

522 kc/s, 574.7 metres; 7 kW.—6.0, Talk. 6.30, Review of Foreign Affairs. 7.0, Humorous Programme. 7.45, Accordion Solos. 8.30, Time and News. 8.45, Concert by the Station Orchestra. 10.0 (approx.), Close Down.

LUXEMBOURG

352 kc/s, 1,191 metres; 200 kW.—French Evening. 7.0 p.m., Chamber Music on Gramophone Records. Quartet in G Minor (Debussy); Sonata in C (Mozart). 7.40, Concert by the Station Orchestra, conducted by Henri Pensis. Overture, Les Francs-Juges (Berlioz); Suite variée (Pierné); Danse macabre (Saint-Saëns). 8.20, Pianoforte Concerto in A Minor (Grieg). 8.50, News in French. 9.0, Concert by the Station Orchestra. Nuits de solitude (Clemens); Suite, La source (Delibes). 9.15, Song Recital by Marie-Thérèse Grossils de Cuyper. 9.50, News in German. 10.0, Gramophone Music. 10.40, Dance Music.

LWOW

788 kc/s, 381 metres; 16 kW.—6.40 p.m., See Warsaw. 10.5, Mandoline Concert. 11.0 (approx.), Close Down.

LYONS

LA DOUA, 644 kc/s, 465.8 metres; 1.5 kW.—7.40 a.m., Radio Gazette for Lyons and the South-East. 8.30, Relay from Paris (Ecole Supérieure), 671 kc/s, 447.1 metres. After the Relay, News.

MADRID

ARANJUEZ (EAQ), 10,000 kc/s, 30 metres; 20 kW.—6.0 to 8.0, Programme for Listeners in the Canary Islands, Guinea and Europe. 6.0, Concert of Popular Music. 7.15, Talk. 7.30, Light Music. 8.0 to 10.30, Interval. 10.30, Variety Programme relayed from Madrid (EAJ7). 12 Midnight till Close Down, Programme in English by the I.B.C. I.B.C. Concert. Dreams on the Ocean; The Siege of Monte Carlo; A South American Romance: Whistle and blow your cares away; There's a House on the Hill; Cañcion de Amalio; A penny for your Thoughts; A Song, a Kiss, a Girl. 12.30 a.m. (Sunday), I.B.C. Good-night Melody.

MADRID

EAJ7, 707 kc/s, 424.3 metres; 2 kW.—7.0 p.m., Chimes, Exchange, Talk and Dance Music. 8.15, Topical Review. 8.30, Interval. 9.15, English Lesson. 9.30, Chimes, Time, Topical Review. 9.40 (approx.), Variety Programme with Margarita Cuelo (Soprano) and the Author, Luis de Tapia (Readings). 11.45, Topical Review. 12 Midnight (approx.), Close Down.

MALMO.—See Stockholm.

MILAN.—See Turin.

MORAVSKA-OSTRAVA

1,137 kc/s, 263.8 metres; 11 kW.—3.0 p.m., Military Band Concert. 3.50, See Prague. 4.25, Gramophone Music. 4.35, See Prague. 4.50, Talk. 5.5, Topical Talk. 5.15, See Prague. 5.25, Concert of Light Music by the Station Orchestra. 6.0 to 9.15, See Prague. 9.15, See Brno. 10.30 (approx.), Close Down.

MOSCOW

TRADES UNION, 300 kc/s, 1,000 metres; 100 kW.—10.45 a.m., Weather. 1.45 p.m., Weather Report. 2.0, Musical and Literary Programme. 3.0, Wireless Talk. 3.30, Voronaia Slobodka—Comedy (Ilf and Petrov) with Music. 4.30, Talk: Science and Technics. 5.30, Beethoven and Brahms Chamber Concert. 8.0, News. 8.30, Programme Announcements. 8.55, Chimes from the Red Square. 9.5, Press Review. 10.0, Weather.

MOTALA.—See Stockholm.

MUHLACKER.—See Stuttgart.

MUNICH

563 kc/s, 533 metres; 60 kW. Relayed by Augsburg and Kaiserslautern, 536 kc/s, 560 metres; and Nürnberg, 1,256 kc/s, 239 metres.—4.0 p.m., Orchestral Concert, conducted by Erich Kloss: Overture, L'oca del Cairo (Mozart); Zigennerlieder (Brahms); Polonaise and Rondo (Weber); Schubert Potpourri (Ralf); Waltz from Baby (Heuberger); Potpourri, Musikalisches Kunterbunt (Schmalstich); Wiegeliend (Kjerull); Spanische Patrouille (Deshayes). 5.0, Programme for Young People. 5.30, German Folk Songs to the Lute by Robert and Lies Kothe. 5.45, Wireless Hints. 6.0, Transmission for all German Stations, relayed from Heilsberg. 7.0, Variety Concert by the Station Orchestra and Soloists: Conductor: Karl List; Soloists: Arno Eichhorn (Bass), Ernst Krauss (Piccolo), Franz Heigl (Trumpet), and Josef Machor (Xylophone): Hauptmann-Göring-Marsch (Taubel); Overture, Edelweiss (Komzak); Humorous Items; Piccolo and Trumpet: Blefant and Mücke (Klug); Im schönen Tal der Isar (Löhr); Xylophone Solos: (a) Alsatian Peasant Dance (Merking), (b) Polka, Herzklopfen (Rieder); Two Bass Solos: (a) Song from Martha (Flotow), (b) Als Biblim klein (Nikolai); Waltz, Die Hydropathen (Gungl); Purzelbaum-Galopp (Lincke). In the interval, Talk from Nürnberg. 9.0, Time and News. 10.0, Serenade by the Radio Dance Band. 11.0 (approx.), Close Down.

NAPLES.—See Rome.

NOTODDEN.—See Oslo.

OSLO

277 kc/s, 1,083 metres; 60 kW.—Relayed by Fredrikstad, 815 kc/s, 368.1 metres; Hamar, 522 kc/s, 574.7 metres; Notodden, 671 kc/s, 447.1 metres; Porsgrund, 662 kc/s, 453.2 metres; and Hjukan, 671 kc/s, 447.1 metres.—3.30 p.m., Gramophone Music. 4.15, Programme for Children. 5.15, Concert of Norwegian Music. 5.45, Talk on Economics. 6.0, Announcements, Weather and News. 6.30, Concert by the Station Orchestra, conducted by Kramm. Overture, Die Matrosen (Flotow); Second Suite from L'Arlésienne (Bizet); Intermezzo from L'Amica Fritz (Mascagni); Selection from Cavalleria rusticana (Mascagni); The Nutcracker Suite (Tchaikovsky). In an interval at 7.0, Time Signal and Humorous Recitation. 7.50, Talk. 8.20, Concert (contd.): Persian Dance (Svendson); Potpourri of Popular Norwegian Melodies (Schütttauf); Norwegian Military March (Olsen). 8.40, Weather and News. 9.0, Topical Talk. 9.15, Variety Programme. 9.30, Dance Music on Gramophone Records. 10.30 (approx.), Close Down.

OSTERSUND.—See Stockholm.

PALERMO

558 kc/s, 537.6 metres; 3 kW.—7.0 p.m., Dopolavoro Notes, Tourist Talk, Agricultural Report and Giornale Radio. 7.20,

Gramophone Music. In the interval at 7.25, Sports Notes, and at 7.30, Time and Announcements. 7.45, Primarosa—Operetta in Three Acts (Pietri). In the intervals, Book Review and Notes. 10.0, Giornale Radio.

PARIS

POSTE PARISIEN, 914 kc/s, 328.2 metres; 60 kW.—7.0 p.m., Gramophone Music. 7.15, Le Journal Parlé. 7.30, Mendelssohn Music on Gramophone Records: Spring Song; The Bee's Wedding; Die Spinnerin; Scherzo from A Midsummer Night's Dream. 7.50, The Week's Review. 8.0, Talk. 8.25, Gaillard Concert of Chamber Music. Soloists: Mme. Mildah Pona, Lucien Bellanger (Violin) and the Composer. 9.10, Concert. 11.0, News.

PARIS

RADIO PARIS, Call CFR, 174 kc/s, 1,725 metres; 75 kW.—7.30 a.m., Weather and Physical Culture. 7.45, Gramophone Records. Leila (Dauber); L'Etoile (Delmet); vous êtes jolie (Delmet); Moorish Serenade (Chapi); Dolorita (Dukas-Gardoni). 8.0, Weather and Press Review. 9.0 to 11.0, Concert, relayed from the Hall of the Old Conservatoire. 12 Noon, Gramophone Records. Pour qu'on rigole (Sylvano); Parfums viennois (Curti); Adieu Hawaii (Bordin); Paris Musette (Marceau); Mariannina (Guida); Lolita (Egen-Grothe); Mause (Abraham); My Heart is Yours (Brown); Eugene Onegin—Opera in Three Acts (Tchaikovsky), relayed from the Opera House. In the intervals, News and Weather. After the Programme, Dance Music by the Vlaseks Band. 10.0 (approx.), Close Down.

RJKAN.—See Oslo.

PITTSBURGH

KDKA, 950 kc/s, 306 metres; 50 kW. Relayed by W8XK on 48.85 metres; and 25.27 metres.—7.0 to 11.0 p.m., New York Relay. 7.0, Musical Originalities. 7.30, Concert Echoes. 8.0, Words and Music. 8.30, Wealth of Harmony. 9.0, Dance Masters. 9.30, Concert Favourites. 10.0, Casino Orchestra. 10.30, Neil Sisters. 10.45, Orphan Annie. 11.0, News and Piano Classique. 11.15, Sports, Pat Healey. 11.30, A Recreo-Bill and Alex. 11.45, Wing Dope, from New York. 12 Midnight, Happy Felton's Orchestra. 12.30 a.m. (Sunday) to 3.0, New York Relay. 12.30 a.m., Circus Days. 12.45, Arie, Judy and Zeke. 1.0, Waldorf Astoria Orchestra. 1.30, Sous les Ponts de Paris. 2.0, Jambouree. 3.0, Behind the Law.

PORSGRUND.—See Oslo.

PRAGUE

614 kc/s, 428.6 metres; 120 kW.—3.0 p.m., See Moravská-Ostrava. 3.50, Programme for Young People. 4.15, Talk for Workers. 4.25, Gramophone Music. 4.35, Czech Lesson for Germans. 4.50, Gramophone Music. 5.5, Agricultural Programme. 5.15, Talk for Workers. 5.25, News in German. 5.30, German Transmission: Savitri—Opera di camera (Holst). 6.0, Time and News. 6.10, Reading. 6.25, Variety Programme. 7.40, Marie Majerova reads from her own Works. 7.55, Brass Band Concert. 8.30, Concert by the Station Orchestra, conducted by Parik. Overture, Sebastian and Viola (Weis); Polichinelle Op. 106 (Provažnik); Waltz, Roses from the South (Strauss); March (Kubin). 9.0, Time, News and Sports Notes. 9.15, See Brno. 10.30 (approx.), Close Down.

RADIO-SUISSE ROMANDE

SOTTENS, 743 kc/s, 403 metres; 25 kW.; and Geneva, 395 kc/s, 760 metres.—6.0 to 6.15 a.m. (from Lausanne), Gymnastics. 11.28, Time Signal from Neuchâtel Observatory. 11.30, News and Weather. 11.40 (from Lausanne), Gramophone Music. 12 Noon (from Lausanne), Financial Notes. 12.10 p.m. (from Geneva), Gramophone Concert. 1.0, Interval. 2.58, Time Signal from Neuchâtel Observatory. 3.0 (from Lausanne), Concert by the Small Station Orchestra, conducted by Moser. 3.45 (from Lugano), Concert. 5.0 (from Geneva), Programme for Children. 5.20 (from Geneva), Talk for Young People; The League of Nations. 5.40 (from Geneva),

Film Talk. 6.5 (from Geneva), Talk: The Music Season. 6.30 (from Geneva), Radio Chronicle. 7.0 (from Geneva), Song Recital. 7.20, Mozart Concert by the Radio-Suisse Romande Orchestra, conducted by Echenard. Soloist: Emile Huber (Pianoforte); The Paris Symphony, Concerto in G for Pianoforte and Orchestra. Contredanses; Rondo, from the Concerto in D for Pianoforte and Orchestra. 9.0, News and Weather. 9.10 (from Geneva), Talk: The Work of the League of Nations.

REYKJAVIK

250 kc/s, 1,200 metres; 21 kW.—11.0 a.m., Weather Forecast. 1.15 p.m., Variety Programme. 4.0, Weather Forecast. 8.5, Programme for Children. 8.10, Weather Forecast. 8.20, Music and Announcements. 9.0, Fireside Programme. 10.0, Time and News, followed by Dance Music. 1.0 a.m. (Sunday), Close Down.

RIGA

572 kc/s, 525 metres; 15 kW.—5.30 p.m., Eugene Onegin—Opera in Three Acts (Tchaikovsky), relayed from the Opera House. In the intervals, News and Weather. After the Programme, Dance Music by the Vlaseks Band. 10.0 (approx.), Close Down.

ROME

Call 1R0, 680 kc/s, 441 metres; 60 kW. Relayed by Naples, 941 kc/s, 319 metres; Milan (Vigentino), 662 kc/s, 453.2 metres from 7.45 p.m.; and 2R0, 11,810 kc/s, 25.4 metres, from 4.15 p.m. (approx.).—11.30 a.m., Gramophone Music. 12 Noon, Orchestral Concert. In the interval from 12.30 to 12.45 p.m., Giornale Radio and Exchange. 1.0, Time and Announcements. 3.30, Children's Radio Review. 3.55, Giornale Radio and Report of the Royal Geographical Society. 4.10, Weather. 4.15 to 5.0, Orchestral Concert. 5.40 (Naples), Shipping and Sports Notes. 5.45, Morse Signals and Dopplavoro Report. 6.0, Tourist Report. 6.10, Wheat Market Report. 6.30, News in Foreign Languages. 6.40, Giornale Radio. 7.0, Time and Announcements. 7.15, Song Recital by Vera Nadia Poggioni (Soprano). 7.30, Giornale Radio and Sports Notes. 7.45, Gramophone Music. 8.0, See Turin. 10.0 (approx.), Giornale Radio.

SALZBURG.—See Vienna.

SCHENECTADY

WQY, 790 kc/s, 379.5 metres; 50 kW. Relayed at intervals by W2XAF on 31.48 metres, and by W2XAD on 19.56 metres.—12.45 a.m. (Sunday), Stock Reports. 1.0 to 3.0, New York Relay. 1.0, Rollickers. 1.15, Herman and Banta (Instrumentalists). 1.30, Sous les Ponts de Paris. 2.0, Baron Munchausen. 2.30, Popular Programme. 3.0, Saturday Night Dancing Party, from New York, followed by Programme Résumé.

SCHWEIZERISCHER

LANDESENDER

BEROMUNSTER, 653 kc/s, 459 metres; 60 kW.; Basle, 1,229 kc/s, 244.1 metres; and Bern, 1,220 kc/s, 245.9 metres.—5.50 to 6.5 a.m., Gymnastics. 11.0 (from Bern), Light Music on Gramophone Records. 11.25, Time Signal from Neuchâtel Observatory, Weather and News. 11.40 (from Bern), Gramophone Music (cont'd.). 12.25 p.m. (from Bern), Time, Weather and Exchange. 12.30 (from Bern), The Listeners' Quarter, of an Hour. 12.45 (from Bern), Book Review. 1.15 (from Bern), Swiss Gramophone Music. In the interval at 1.30 (from Bern), Talk: How Sugar is Made. 2.0 to 3.0, Interval. 3.0 (from Bern), Concert by the Freiburg Harp Society. 3.30 (from Bern), Talk. 3.45, Programme (to be announced) relayed from Lugano. 5.0 (from Basle), Gramophone Music. 5.30 (from Basle), Programme for Children. 6.0, Chimes from Zürich Churches. 6.15 (from Basle), Time, Weather and Market Prices. 6.20 (from Basle), Opera and Operetta Music on Gramophone Records. 7.0 (from Basle), Kreuz and Quer—Radio Sequence (Paul Meyer-Gutzwiller and Werner Hausmann). 7.30 (from Basle), Concert by the Basle Orchestral Society. In the interval at 8.0, Weather and News. 9.10 (from Basle), Dance Music. 10.0 (approx.), Close Down.

SOTTENS.—See Radio-Suisse Romande.

STOCKHOLM

680 kc/s, 436 metres; 55 kW. Relayed by Boden, 244 kc/s, 1,229.5 metres; Göteborg, 932 kc/s, 322 metres; Hörby, 1,166 kc/s, 257 metres; Motala, 221.5 kc/s, 1,354.4 metres; Östersund, 389 kc/s, 770 metres; and Sundsvall, 554 kc/s, 542 metres.—3.0 p.m. (from Göteborg), Concert: March, Stars and Stripes (Souza); Waltz; (Moszkowski); Overture, Mignon; (Thomas); Sogno d'amore (Bece); Selection from Madame Butterfly (Puc-

cini); Serenade (Peterson-Berger); Tango, Die Sache, die man Liebe nennt (S. Straus). 4.5, Programme for Children. 4.30, Talk. 5.0, Gramophone Music. 6.0, Dialogue. 6.30, Comedy (Oljelund). 7.0, Dance Music by a Wind Instrument Orchestra. 7.30, Dialogue. 8.0 (from Östersund), Cabaret Programme. 8.45, News and Weather. 9.4, Dance Music. 10.0 (approx.), Close Down.

STRASBOURG

869 kc/s, 345 metres; 11.5 kW.—11.30 a.m., Modern French Music on Gramophone Records. Extracts from Le Festin de l'Araignée (Roussel); Elégie (Fauré); Vie antérieure (Duparc); Extracts from Korrigane (Widor); Scène et pas des deux pigeons from Les deux Pigeons (Messager); Mother (Goose Suite) (Ravel); Marche écossaise (Debussy). 12.45 p.m., News. 1.0, Time and Exchange. 1.5, Gramophone Concert. Overture, Die Fledermans (Joh. Strauss); Zigeunerweisen (Sarasate); Turkish Patrol (Michaelis); Patrouille (Popy); Overture, Mignon (Thomas); Selection from Benvenuto Cellini (Berlioz); Hungarian March from The Damnation of Faust (Berlioz); Offenbach Potpourri. Selection from The Daughter of the Regiment (Donizetti). 2.0, Legal Talk in German. 2.15, Gramophone Concert. 3.0, Music Talk. 4.0, Recital by Caruso on Gramophone Records. 5.0, Symphony Concert, relayed from Paris (Eiffel Tower). 7.0, French Lesson. 7.15, Horticultural Talk. 7.30, Time and News. 7.45, Gramophone Music. 8.0, Press Review in German, Lottery Results and Announcements. 8.30, Concert by the Station Orchestra, conducted by Maurice de Villers. Soloists: Faniard (Tenor) and Mme. Inès Maujean (Soprano); Ballet Airs (Gluck); Soprano Solo: Air (Handel); Flute Solo: Mimmet from Orpheus (Glück); Tenor Solo from Joseph (Méhul); Gipsy Suite for Violin and Orchestra (Wormser); Tenor Solos: Neapolitan Songs; Concert Piece for Pianoforte and Orchestra (Chaminade); Selection from Otello (Verdi). In the interval at 9.30 (approx.), Press Review. 10.30, Dance Music, relayed from the Savoy. 12 Midnight (approx.), Close Down.

STUTTGART

MUHLACKER, 832 kc/s, 360.5 metres; 60 kW. Relayed by Freiburg, 527 kc/s, 570 metres.—12.35 p.m., See Langenberg. 1.30, Programme for Young People. 2.15, Morse Lesson. 2.30 (from Karlsruhe), Accordion Concert. Conductor and Soloist: Baumgartner. Der alte Berner Marsch (arr. Hebling); Potpourri of Strauss Waltzes (arr. Thöni); Accordion Solo; Military March No. 1 (Schubert); Ländler, Lustig und fidel (Hebling); March, Tiroler Holzhaackerbaub'n (J. F. Wagner). 3.0, Concert by the Station Orchestra and the Tegernseer Trio. Conductor: Gustav Görlisch. Overture, Die schöne Galathée (Suppé); Selection from The Mikado (Sullivan); Martin-Walzer (Zeller); March, Kunst und Natur (Schrannmuller); Trio: Three Pieces (Kranzov): (a) Idyll, Frühlings-sänger im Walde, (b) Alm-Lieder, (c) Tölzer Schützen-Marsch; Potpourri of Popular Songs (Lincke); Melody (Löhrl); Waltz, Ball-sirenen (Lehar); Brucker Lager-Marsch (Kral); Trio: Three Pieces: (a) Upper Bavarian Ländler (Reiter); (b) Bavarian Song Potpourri; (c) Kaiserjäger-Marsch (Mühlberger). 5.0, See Frankfurt. 5.20, Review of the Week. 5.35 (from Freiburg), Talk for the Centenary of the Birth of Alfred Nobel. 5.50, Time and Announcements. 6.0, Transmission for all German Stations, relayed from Heilsberg. 7.0 to 9.20, See Frankfurt. 9.20, Talk: Things you should know. 9.30, News. 9.45, Concert of Light Music. 10.0 till Close Down. See Langenberg. 1.0 a.m. (Sunday), Close Down.

SUNDSVALL.—See Stockholm.

TOULOUSE

779 kc/s, 385 metres; 8 kW.—6.0 p.m., News. 6.15, Popular Songs. 6.30, Orchestral Music. 7.0, Violin Recital: Zigeunerweisen (Sarasate); Meditation from Thais (Massenet); Cavatina (RAFF); Träumerei (Schumann). 7.15, News. 7.30, Arias from Operas: Aria from Der Freischütz (Weber); Aria from Hérodiade (Massenet); Marguerite's Aria from Mephistopheles (Boito); Cavatina from Norma (Bellini). 7.45, Music by a Viennese Orchestra. 8.0, Songs from Sound Films. 8.15, Military Music. 8.30, Songs from Operettas. 8.45, Orchestral Pieces. 9.0, Tosca—Opera (Puccini)—Concert Version, followed by Orchestral Music. 10.0, Light Music. 10.15, North African News. 10.30, Concert for Listeners in Morocco. 11.0, Request Music. 11.15, Dance Music. 12 Midnight, News. 12.5 a.m. (Sunday), Opéra-Comique Music: Airs from (a) The Fair Maid of Perth (Bizet), (b) Suppho (Massenet); Duet from Le Châlet (Adam). 12.15, Orchestral Music. 12.30 (approx.), Close Down.

TRIESTE

1,211 kc/s, 247.7 metres; 10 kW.—4.10 p.m. till Close Down. See Turin.

TRONDHEIM.—See Oslo.

TURIN

1,096 kc/s, 273.7 metres; 7 kW. Relayed by Milan, 906 kc/s, 331.5 metres; Genoa, 959 kc/s, 312.8 metres; and Florence, 599 kc/s, 500.8 metres.—4.10 p.m., Talk for Women. 4.20, Gramophone Music. 5.0 to 5.5 Weather. 5.40, Giornale Radio, Lottery Results, Dopplavoro Announcements and Gramophone Music. 6.0, Time, Tourist Talk and Gramophone Music. 6.10, Agricultural Notes and Wheat Market Report. 6.20, News in Foreign Languages. 6.40, Gramophone Music. 7.0, Announcements, Giornale Radio and Weather. 7.25, Talk: Events and Problems, followed by Gramophone Music. 8.0, Aida—Opera in Four Acts (Verdi), relayed from the Vittorio Emanuele Theatre. In the intervals: Talk, Book Review and Giornale Radio.

VATICAN CITY

15,120 kc/s, 19.84 metres (Morning); and 5,969 kc/s, 50.26 metres (Evening); 10 kW.—11.0 to 11.15 a.m., Religious Announcements in Various Languages. 8.0 to 8.15 p.m., Religious Information in Italian.

VIENNA

581 kc/s, 517 metres; 100 kW. Relayed by Graz, 852 kc/s, 352.1 metres; Innsbruck, 1,058 kc/s, 283 metres; Klagenfurt, 662 kc/s, 453.2 metres; Linz, 1,220 kc/s, 245.9 metres; and Salzburg, 1,373 kc/s, 218.5 metres.—10.30 a.m., Gramophone Concert. 10.55, Weather. 11.0, Orchestral Concert, conducted by Max Geiger: Festival Overture (Leutner); Waltz, Les Sirènes (Waldteufel); Selection from La Bohème (Puccini); Entry March of the Boyards (Halvorsen); Suite Campestre (Amadei); Potpourri of Romanian Songs and Dances (Geiger). 12 Noon, Time and News. 12.10 p.m., Concert (cont'd.). Bizet Fantasia (Urbach); Caucasian Suite (Ippolitov-Ivanov); Potpourri, Dividenden (Moresna); Tango from The Lady of the Rainbow (Gilbert); Potpourri, Wiener Spezialitäten (Hrubý); March, Tatzmannsdorfer Klänge (Geiger). 2.0, Time, Weather, and Market Prices. 2.15, Italian Lesson. 2.45, Mandoline Concert, conducted by Dr. Leopold Bracharz. 3.20, Talk with Gramophone Illustrations: The Piedigrotta Festival in Naples. 3.55, Gramophone Concert. 5.0, Talk: The Nobel Prize and its Founder. 5.30, Talk: World Events of the Past Month. 6.0, Topical Talk. 6.15, Time and News. 6.30, Demonstration in Honour of Dr. Dollfus by the Austrian Storm Troops, with an Address by the Minister for Education and Justice, Dr. Kurt Schuschnigg, relayed from the Konzerthausball. 7.30, Today's Motto. 7.35, Merry Student Days—Concert by the Wiener Symphoniker, conducted by Josef Holzer, and the Vienna Male Voice Choir. Soloists: Maria Tauber-Proske (Soprano) and Dario Medina (Tenor); Extracts from Jung-Heidelberg (Müllacker-Reiterer); Waltz, Studentlust (Joh. Strauss); Choir: Student Song, Filia hospitalis; Chorus and Duet from Prinzess Gretel (Reinhardt); Potpourri of Student Songs (Klimsch); Extracts from I left my Heart in Heidelberg (Raymond); March, Burschen heraus (Eyster); Chorus: Student Song, Wir liegen hinaus in die son-nige Welt; Soprano Song from Der arme Jonathan (Müllacker); Tenor Solo, Beim wirt zum gold'nen Fassel (Precht-Riedinger); Tenor Solo (Raymond); Student March (Rieger). 9.5, News. 9.20, Dance Music by Claire Hegedüs and her Orchestra, relayed from the Café Palmhof. After the Programme, Announcements.

WARSAW

212.5 kc/s, 1,411 metres; 120 kW.—10.57 a.m., Time Signal and Fanfare from St. Mary's Church, Cracow. 11.5, Military Music on Gramophone Records. 11.30, Radio Journal and Weather. 11.35, Dance Music on Gramophone Records. 12 Noon, Interval. 2.30 p.m., Economic Notes. 2.40, News. 2.55, Aviation Report and Anti-Gas Drill. 3.0, Programme for Invalids, relayed from Lwów, 788 kc/s, 381 metres. 3.40, French Lesson. 3.55, Concert by the Warsaw String Quartet: Quartet in F (Dvorak); Quartet in E Minor (Smetana). 4.30, Agricultural Press Review, relayed from Lwów. 5.0, Talk: Poland To-day. 5.20, Light Music from the Adria Café. 6.5, Miscellaneous Items. 6.25, Reading. 6.40, Radio Journal. 7.0, Concert by the Station Orchestra, conducted by Nawrot. Soloist: Mierzejewski (Songs). Selection from Herbstmanöver (Kálmán); Songs; Minuet (Kiesewetter); Indian War Dance (Lumbye); Selection from Il carillon magris (Pick-Mangiala); Pizzicato Polka (Jos. Strauss); Songs; Waltz, Badner Mädel (Komzak); March (Lewanowski). 8.0, Wireless Talk. 8.15, Chopin Recital. 9.0, Talk in Foreign Language. 9.15, Sports Notes. 9.25, Dance Music from the Ziemińska Café. In the interval at 10.0, Weather and Police Notes.

WILNO

533 kc/s, 563 metres; 16 kW.—6.6 p.m., Weekly Lithuanian Review. 6.20, Miscellaneous Items. 6.25, Programme for Students. 6.40, Programme Announcements. 6.45, Programme from Warsaw. 7.0, Concert of Request Gramophone Music. 8.0 till Close Down. See Warsaw.

ZÜRICH.—See Schweizerischer Landessender.

PRINCIPAL BROADCASTING STATIONS OF EUROPE

Arranged in Order of Wavelength

Metres.	kc/s.	kW.	Station.	Tuning Positions.	Metres.	kc/s.	kW.	Station.	Tuning Positions.
1935	155	7	Kaunas (Kovno) (Lithuania)		368.1	815	0.7	Fredriksstad (Norway). (Relays Oslo)	
1875	160	8.5	Huizen (Holland) (Kootwyk, 50kW., after 3.40 p.m.) (K.R.O. and N.C.R.V. programmes.)		364.1	824	1	Bergen (Norway)	
1796	117	40	Lahti (Finland)		363.6	825	13	Algiers (Algeria)	
1725	174	75	Radio Paris, CFR		360.6	832	60	Mühlacker (Stuttgart) (Germany)	
1635	183.5	60	Berlin (Deutschlandsender) (Germany). (S.-W. Stn. DJA on 31.38 m., DJB on 19.73 m., DJC on 49.83 m., DJD on 25.51 m., DJE on 16.86 m.)		355.9	843	50	London Regional (Brookmans Park)	
1554.4	19	30	Daventry National		352.1	852	7	Graz (Austria). (Relays Vienna)	
1538	195	7	Ankara (Angora) (Turkey)		348.8	860	7.6	Barcelona, EAJ1 (Spain)	
1481	202.5	500	Moscow, RV1 (Old Komintern) (Russia)		345.2	869	11.5	Leningrad, RV70 (Russia)	
1446	207.5	13	Eiffel Tower, FL, Paris		341.7	878	35	Strasbourg, PTT (France)	
1412	212.5	120	Warsaw I (Poland)		338.2	887	15	Brno (Brunn) (Czechoslovakia)	
1380	217.5	100	Novosibirsk, RV76 I (Russia)		335	896	5	Brussels II Velthem (Belgium). (In Flemish)	
1354.4	221.5	30	Motala (Sweden). (Relays Stockholm)		334.4	897	1.9	Cadiz (Spain)	
1304	230	100	Moscow, WZSPS (Trade Union) (Russia)		331.5	905	50	Poznan (Poland)	
1200	250	5	Stamboul (Turkey)		328.2	914	60	Milan (Italy). (Relays Turin)	
1200	250	21	Reykjavik (Iceland)		325	923	60	Poste Parisien (France)	
1190	252	200	Luxembourg		321.9	932	10	Breslau (Germany)	
1170	256	25	Tashkent, RV11 (Russia)		318.8	941	0.25	Göteborg (Sweden). (Relays Stockholm)	
1154	260	60	Kalundborg (Denmark). (Relays Copenhagen)		318.8	941	1.5	Dresden (Germany). (Relays Leipzig)	
1154	260	20	Monte Ceneri (Switzerland). (Temporarily closed.)		315.8	950	1.6	Naples, INA (Italy). (Relays Rome)	
1117	268.5	40	Moscow, Popoff RV58 (Russia)		312.8	959	0.7	Marseilles, PTT (France)	
1083	277	60	Oslo (Norway)		312.8	959	1.7	Radio Vitus (Paris). (S.-W. Stn. on 43.75 m.)	
1071	280	35	Tiflis, RV7 (Russia)		312.8	959	1.7	Cracow (Poland)	
1035	290	36	Kiev, RV9 (Russia)		312.8	959	10	Genoa, IGE (Italy). (Relays Turin)	
1000	300	100	Moscow RV39 (Russia). (S.-W. Stn. on 50 m.)		309.9	968	50	West Regional (Washford Cross)	
938	320	20	Khar'ov, RV4 (Russia)		307	977	0.75	Zagreb (Yugoslavia)	
857	350	100	Leningrad (Russia)		304	986	13	Bordeaux Lafayette, PTT (France)	
840	357	18.5	Budapest (Hungary)		301.5	995	50	North National (Manchester)	
825	363.6	50	Sverdlovsk, RV5 (Russia)		298.8	1004	11	Tallinn (Estonia)	
760	395	1.3	Geneva (Switzerland). (Relays Sottens)		296.1	1013	20	Hilversum (Holland). (7 kW. before 4.40 p.m.) (V.A.R.A., A.V.R.O. and V.P.R.O. programmes.)	
720	416.6	20	Moscow, RV2 (Experimental) (Russia)		293.5	1022	0.7	Limoges, PTT (France)	
690	434.6	1.5	Oulu (Uleaborg) (Finland)		293.5	1022	2.6	Kosice (Czechoslovakia)	
680	441.2	0.6	Lausanne (Switzerland). (Relays Sottens)		291	1031	13.2	Viipuri (Viborg) (Finland). (Relays Helsinki)	
574.7	522	7	Ljubljana (Yugoslavia)		288.3	1040	50	Scottish National (Falkirk)	
568.1	528	2	Grenoble (France)		288.3	1040	1	Bournemouth. (Relay Station)	
566	530	1.5	Hanover (Germany). (Relays Hamburg)		286	1049	0.8	Montpellier (France)	
563	533	16	Wilno (Poland). (Relay Station)		284.8	1053	0.7	Lyons (Radio-Lyon) (France)	
560	536	1.5	Kaiserslautern (Germany). (Relays Munich)		283.6	1058	0.5	German Relays (Berlin, Magdeburg, Stettin)	
550	545	18.5	Budapest No. 1 Lakihegy (Hungary)		283.6	1058	0.5	Innsbruck (Austria). (Relays Vienna)	
542	554	10	Sundsvall (Sweden). (Relays Stockholm)		282.2	1063	2	Lisbon CT 1AA (Portugal). (Short-wave Station on 31.25 m.)	
537.6	558	3	Palermo (Italy)		281.2	1067	0.75	Copenhagen (Denmark)	
533	563	60	Munich (Germany)		278.8	1076	13.5	Bratislava (Czechoslovakia)	
525	571	15	Riga (Latvia)		276.5	1085	60	Heilsberg (Germany)	
517.2	580	100	Vienna (Bisamberg) (Austria)		273.7	1096	7	Turin (Italy)	
509	589	15	Brussels No. 1, Velthem (Belgium). (In French)		271.5	1105	1.3	Rennes, PTT (France)	
500.8	599	20	Florence, IPI (Italy) (Relays Turin)		269.8	1112	20	Bari (Italy) (Relays Rome)	
495.8	605	1.2	Tröndelag (Norway)		269.8	1112	0.25	Bremen (Germany). (Relays Hamburg)	
488.6	614	120	Prague (Czechoslovakia)		267.6	1121	0.75	Valencia (Spain)	
480	625	50	North Regional (Manchester)		267.4	1122	6.25	Nvireghaza (Hungary). (Relays Budapest)	
472.4	635	60	Langenberg (Germany)		265.8	1128.5	1.3	Lille, PTT (France)	
465.8	644	1.5	Lyons la Doua, PTT (France)		263.8	1137	11.2	Moravska Ostrava (Czechoslovakia)	
459.4	653	60	Beromünster (Schweizerischer Landessender) (Switzerland)		261.5	1147	50	London National and West National	
453.2	662	0.25	San Sebastian, EAJ8 (0.6 kW.); Pori (1.0 kW.) (Finland); Danzig (0.5 kW.) (relays Heilsberg); Klagenfurt (0.5 kW.) (Austria) (relays Vienna).		259.3	1157	17	Frankfurt-a.-M. (Germany)	
453.2	662	4	Agen (France)		259.3	1157	2.3	Trier (Germany). (Relays Frankfurt)	
450.3	666	20	Milan (Vigentino) (Italy). (Relays Rome)		257.1	1167	10	Hörby (Sweden). (Relays Stockholm)	
447.1	671	7	Madóna (Latvia). (Relays Riga)		255.1	1176	0.7	Toulouse, PTT (France)	
441.2	680	50	Paris, Ecole Supérieure, PTT		253.1	1185	5	Gleitwitz (Germany). (Relays Breslau)	
435.4	689	55	Rome, IRO. (S.-W. Station, 2RO on 25.4 m.)		249.6	1202	0.8	Barcelona, EAJ15 (Assoc. Nat.) (Spain)	
430.4	697	2.5	Stockholm, SASA (Sweden)		247.7	1211	10	Juan-les-Pins, Nice (France)	
424.3	707	2	Belgrade (Yugoslavia)		245.9	1220		Trieste (Italy). (Relays Turin)	
424.3	707	100	Madrid, EAJ7 (Union Radio)					Berne (0.5kW.) (Switzerland) (relays Beromünster); Eskilstuna (0.2kW.), Sjöfö (0.4 kW.) (Sweden) (relays Stockholm); Cassel (0.25 kW.) (Germany) (relays Frankfurt); Linz (0.5 kW.) (Austria) (relays Vienna); Pietarsaari (0.5 kW.), Turku (Abo) (0.5 kW.) (Finland) (relays Helsinki).	
419.5	715	1.5	Moscow, Imini Stalina (Russia)		244.1	1229	0.5	Basle (Switzerland). (Relays Beromünster)	
416.4	720.5	5	Berlin, Funkstunde (Germany)		242.3	1238	1	Belfast (N. Ireland)	
413	725	60	Rabat (Morocco)		240.6	1247	0.5	Stavanger (Norway)	
408.7	734	16	Athlone (Irish Free State)		238.9	1256	2	Nürnberg (Germany). (Relays Munich)	
403.8	743	25	Katowitz (Poland)		237.2	1265	1	Nimes (France)	
398.9	752	25	Sottens (Radio Suisse Romande) (Switzerland)		237.2	1265	3	Bordeaux, Sud-Ouest (France)	
394.2	761	12	Midland Regional (Daventry)		235.5	1274	0.5	Kristiansand (Norway)	
389.6	770	120	Bucharest (Roumania)		235	1283	1.65	Lodz (Poland). (Relay Station)	
385.1	779	8	Leipzig (Germany)		232.2	1292	0.25	Kiel (Germany). (Relays Hamburg)	
381	788	16	Toulouse (Radiophonie du Midi) (France)		227.4	1319	0.5	Flensburg (Germany). (Relays Hamburg)	
376.4	797	50	Stalino, RV26 (Russia)		225.9	1328	10	Fécamp, Radio-Normandie (France)	
372.2	806	1.5	Lwow (Lemberg) (Poland)		224.4	1337	1	Cork (Irish Free State)	
370.1	810.5	0.8	Scottish Regional (Falkirk)		219.9	1365	1.5	Béziers (France)	
368.1	815		Hamburg (Germany)		218.5	1373	0.2	Plymouth	
			Radio, LL, Paris		218.5	1373	0.5	Salzburg (Austria). (Relays Vienna)	
			Seville, EAJ5 (Union Radio) (1.0 kW.); Galicia EAJ4 (0.2 kW.) (Spain); Bolzano (1.0 kW.) (Italy); Helsinki (10 kW.) (Finland) (relays Lahti); Kharkov, RV20 (10kW) (Russia).		217	1382	0.5	Königsberg (East Prussia). (Relays Heilsberg)	
					217	1382	0.25	Karlstad (Sweden)	
					214.3	1400	1	Aberdeen	
					211.3	1420	1	Newcastle	
					209.8	1430	1.25	Magyarovar, Miskolc and Pecs (Hungary)	

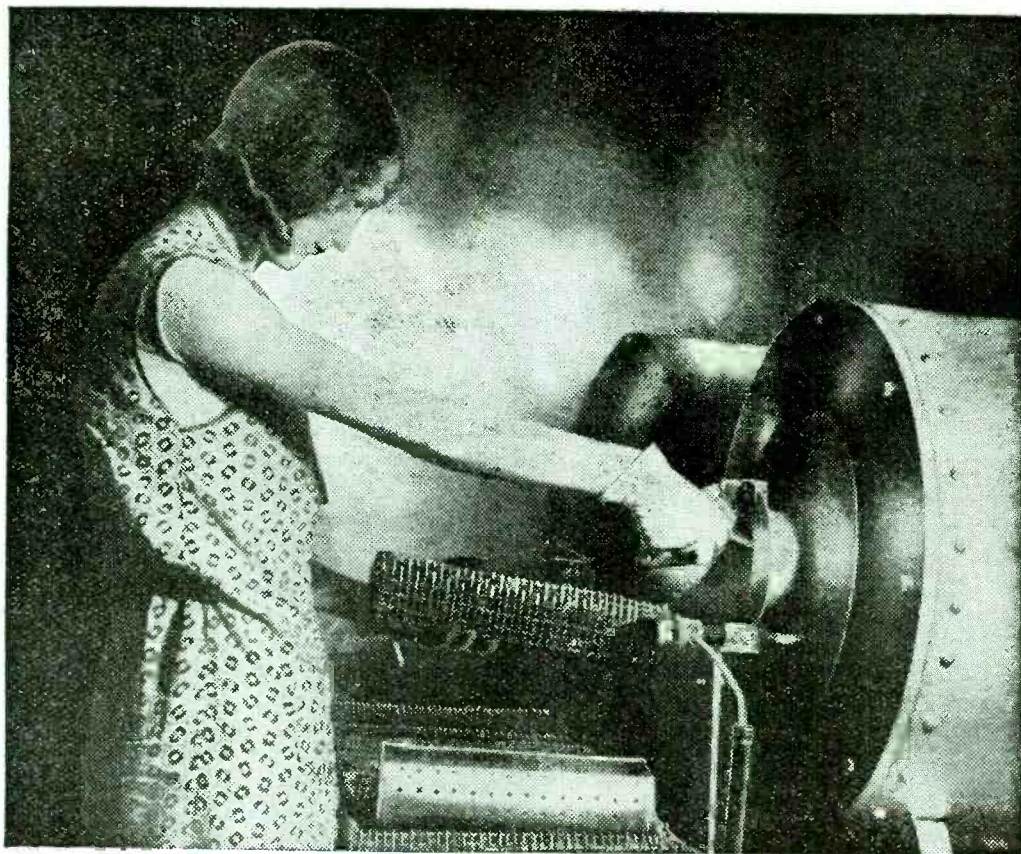

1,000 Degrees Centigrade

There's more—much more—in the manufacture of Cossor Valves than meets the eye. Consider for a moment the nickel anodes. Any impurities in the metal—even minute traces of gaseous matter—might, at a later date, impair the efficiency of the valve. Each one, therefore, is subjected to intense heat in an electric furnace, in an atmosphere of hydrogen, to drive off all impurities. Here is a process which is unseen by the public. Many in fact might consider it an elaborate—and rather unnecessary precaution. Yet it is but one of many similar processes devised by Cossor engineers to safeguard a reputation of which they are justifiably proud. When you buy a Cossor Valve you can be certain that no expense has been spared—that nothing has been left undone—to make sure that it will give you long and dependable service.

*that you may
enjoy **BETTER**
Radio Reception*



COSSOR VALVES

To A. C. COSSOR LTD., Melody Dept., Highbury Grove, London, N.5.
Please send me free of charge, a copy of
the 64-page Cossor Valve Catalogue B14.

Name

Address

W.W. 13/10/33.

A. C. Cossor Ltd., Highbury Grove, London, N.5. Depots at Birmingham, Bristol, Glasgow, Leeds, Liverpool, Manchester, Newcastle, Sheffield, Belfast, Cardiff and Dublin.

Mention of "The Wireless World," when writing to advertisers, will ensure prompt attention.

Practical HINTS and TIPS

MORE often than not, a gramophone pick-up is connected to the detector valve grid in the manner shown in Fig. 1. A consideration of this diagram will show that, as the volume-control potentiometer setting is varied from maximum to minimum, the value of resistance shunted across the grid circuit is similarly changed.

Testing the Vacuum

It may not have occurred to many readers that, if a milliammeter be connected in series with the anode as shown, we have in this arrangement an effective tester for "softness," or deficient vacuum of the valve.

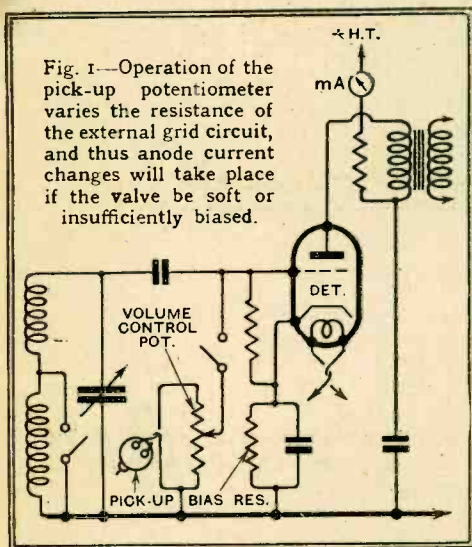

Fig. 1.—Operation of the pick-up potentiometer varies the resistance of the external grid circuit, and thus anode current changes will take place if the valve be soft or insufficiently biased.

If any appreciable change in anode current is produced by operation of the volume control potentiometer, it can be assumed that either "positive" or "negative" grid current is flowing. Provided that sufficient negative bias be applied, "positive" grid current cannot flow; accordingly, if operating conditions are correct, any change in anode current is a definite indication of a "soft" valve.

Any valve other than the detector, provided it operates at the same heater or filament voltage, may generally be inserted temporarily in the detector socket for purposes of test.

IT is useful to know that the latest type of combined detector-oscillator valve—the so-called Pentagrid or Heptode—may be tested, so far as the oscillator section is concerned, in much the same way as when a separate valve is employed for the latter function.

Testing Pentagrid Oscillators

To make a definite test, a milliammeter should be joined in series with the oscillator anode, preferably on the low-potential side of the feed resistance. Then, with the aerial disconnected and no signal coming in, the oscillator reaction coil

AIDS TO BETTER RECEPTION

should be short-circuited, and if all is in order a rise in current should take place.

If there be no change in current we have a certain indication of non-oscillation, under which conditions the set cannot possibly function. This test should be carried out on several wavelengths.

In testing the "New Monodial Super" the meter should be connected on the "earthy" side of the resistance R5, while the experimental short-circuit should be applied between Terminal No. 1 of the oscillator coil assembly and earth.

EVERYONE knows that the effectiveness of an aerial is, apart from the question of height, more or less proportional to its length. But this only holds good if the horizontal span be straight; occasionally one sees indoor aerials which

Indoor Aerials

could be definitely improved by shortening them. For instance, the aerial is sometimes carried round three sides of a room, or even of a narrow hall, the lead-in being taken down from one end; with such an arrangement it is to be expected that the voltage introduced into one side will partially neutralise that in the other, and so the effective length will be actually less than if the aerial were carried along one side of the room.

The design of indoor aerials is hardly susceptible to scientific treatment, but it is always worth while to make a few careful comparative tests before installing a permanent arrangement.

IT sometimes happens that the output from the detector valve is insufficient fully to load the output valve, and so the fitting of an intermediate L.F. stage becomes necessary. As often as not the amplification needed from this stage is quite small—perhaps not more than four or five times.

Low-amplification Intermediate Stages

Provided that an input volume control to the L.F. amplifier be fitted, it does not greatly matter if the intermediate stage be of the conventional high-gain type, giving much greater amplification than is needed. But there is another aspect of the subject that should sometimes be taken into account; the use of excessive magnification tends to increase hum, and to provoke L.F. instability. There is accordingly much to be said in favour of using no more amplification than is strictly necessary; this will often be obtainable from a small power valve coupled by means of a resistance of low value (20,000 ohms or less) to the succeeding output valve.

IT is useful to remember that, from many points of view, the anode circuit of an amplifying valve and the grid circuit of the succeeding valve are identical. With any "one-to-one" coupling, such as choke or resistance, the signal-frequency voltages existing across each circuit are bound to be of almost the same value.

Grid and Anode Circuits

This point may not be immediately apparent from Fig. 2 (a), which represents an ordinary resistance-coupled L.F. stage drawn in the conventional manner. But, by redrawing the amplifier as in diagram (b), it is made clear that anode and grid circuits, linked by a coupling condenser, are in parallel.

All this applies to the H.F. side of the receiver as well as to the L.F. amplifier. The knowledge that these circuits, which appear to be independent, are really in parallel with one another, may often be turned to good account when testing for faults. For instance, when locating hum or intermittent cracklings in a receiver employing the L.F. circuit used as an example, the effect of an experimental short-circuit across either the anode resistance or grid-lead would be almost identical.

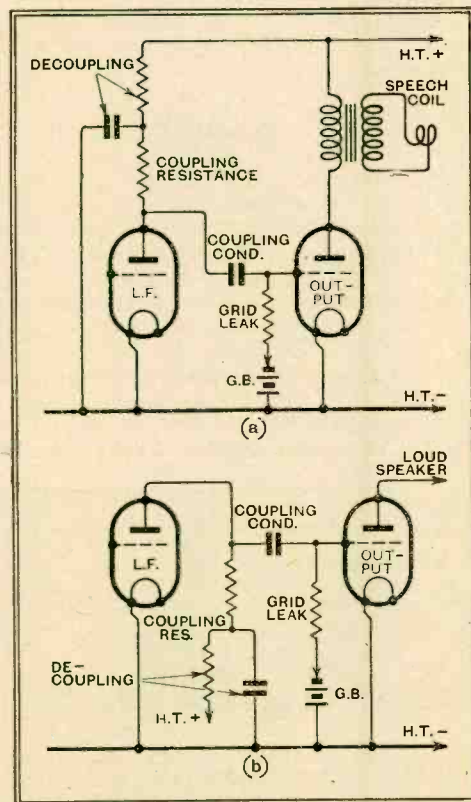

Fig. 2.—The circuit of a conventional resistance-coupled stage is redrawn in diagram (b) to show that grid and anode circuits are in parallel from the signal-frequency point of view.

cal. When one happens to be inaccessible, connection might be made to the other.

Radio Luxembourg

An International Broadcasting Problem

RADIO LUXEMBOURG started some months ago with regular experimental transmissions. These broadcasts are still taking place. To the casual observer they do not bear the mark of "experimental." Luxembourg describes these transmissions as experimental because this station dares not start broadcasting officially on its present wavelength, as this lies in a band reserved for non-public services and can only be used by broadcasting stations after sanction by the countries concerned, and this sanction is lacking. Great Britain has taken a very decided stand against the opening of Radio Luxembourg and also against this station's idea of becoming an international broadcaster. Reasons given are that it would be interfering with the authority of a foreign Government to broadcast, from Luxembourg, programmes addressed to countries outside Luxembourg. Certain Governments in Europe are afraid that a precedent might be created and their carefully built up control of their own broadcasting rendered useless. France and Belgium, on the other hand, are all for the international broadcasting station in Luxembourg, so that when, some time ago, a British protest against Luxembourg was made a few hours later steps were taken by France and Belgium in the opposite direction.

A Finely Equipped Station

The visitor to Radio Luxembourg finds one of Europe's most beautifully laid out broadcasting transmitters working with 200 kW. in the aerial and ample space provided for the addition of a powerful short-wave transmitter. The typical long-wave aerial of the present station still stands, and at the beginning of September there were no signs of any possible changes to adapt the transmitter to the medium wavelength prescribed for it under the Lucerne Plan. In Luxembourg itself a series of beautiful new



MULTI-LINGUAL BROADCASTING.—Léon Moulin, the Luxembourg patois announcer, sharing the microphone with Eva Siewert, who announces in German.

studios have just been completed. Plans are prepared for the building of a large concert hall to act as a studio as well, and a small orchestra has been engaged. There are permanent announcers for French and German and for the Luxembourg patois, and occasional announcers for Italian, Spanish, Dutch, and English. Luxembourg broad-

AN AIR OF PERMANENCY attaches to this view of the massive main entrance door to the Luxembourg transmitter building. Note the design, which suggests that Luxembourg will encircle the world with its new short-wave transmitter.



casting programmes are arranged for a different country each evening. The idea is that Luxembourg, once it has received international sanction, should start broadcasting sponsored programmes for various European countries. In Germany a company was formed some time ago, with the co-operation of the German Post Office and of the semi-official Wolff News Agency, to act as official agent for the selling of Luxembourg "air space" in Germany.

The answer to "What will happen to Luxembourg after January 15th?" is intimately related to the question, "Will the Lucerne Plan come into force on that day?" At the present moment Holland, Sweden, Lithuania, Finland, Poland, Hungary, Greece, and Luxembourg have not adhered to the Lucerne conditions. It is generally understood that attempts are being made during the meeting of the International Union of Broadcasters, which is taking place during this week at Amsterdam (at the invitation of the Dutch broadcasters), to bring these countries into line. This seems a very difficult problem at the present moment, as the main bone of contention is the long waves.

Where the U.I.R. is Powerless

We are inclined to attach much importance to the Union Internationale de Radio-diffusion, but this body is the official expert to the International Union of the Postal Administrations of Europe in all matters regarding broadcasting, and no more. There are even members of the Broadcasters' Union who at one time hoped that they would have authority to arbitrate in cases where any broadcasting station might start direct propaganda against the existing Government in a neighbouring country. These hopes have long since been shattered, and it is therefore excusable to ask why the International Broadcasting Union should pass a resolution against Luxembourg whilst no such action is taken against larger countries which are similarly offending.

At the Amsterdam meeting the U.I.R. has, in its technical committee, had to discuss ways and means of putting the Lucerne

Plan into practice. The committee dealing with legal aspects is, no doubt, studying the problem of what will happen if the Lucerne Plan is not signed by the eight outstanding countries. Their deliberations may bring us closer to a solution of the wavelength problem and international broadcasting as exemplified by Luxembourg, but whether they can tackle political and unfriendly broadcasting is another matter.

I understand that most European postal administrations sent non-participating representation to Amsterdam, as they did not wish that Lucerne should have the same fate as the North and Central American wavelength conference, which has just failed to reach an agreement.

"WANDERING WAVE."

BLUE PRINTS

For the convenience of constructors full-sized blue prints are available of the following popular *Wireless World* sets that have been recently described, price 1s. 6d., post free.

- Short Wave Two.** (November 4th and December 23rd, 1932.)
- Monodial D.C. Super.** (December 2nd and 9th, 1932.)
- Straight Three.** (December 16th, 1932.)
- Modern D.C. Three.** (December 30th, 1932, and January 6th, 1933.)
- All-wave Monodial Super.** (January 27th and February 10th, 1933.)
- Modern A.C. Quality Amplifier.** (February 17th, 1933.)
- Ferrocort III.** (February 24th and March 3rd, 1933.)
- The Class "B" Ferrocort Receiver.** (April 17th, 1933.)
- Universal A.C. Short-wave Converter.** (April 28th, 1933.)
- New Monodial Super.** (July 21st and 28th, 1933.)
- Modern Battery Four.** (August 11th, 1933.)
- D.C. Superhet.** (September 29th, and October 6th, 1933.)

These can be obtained from the Publishers, Hiffe & Sons Ltd., Dorset House, Stamford Street, London, S.E.1.

Visual Tuning Indicator

Practical Notes on the Micromesh "Tunograph"

THE tuning of a receiver fitted with A.V.C. is apt to be more difficult than that of a set not so equipped, for the automatic volume control appears to flatten the tuning, and a precise setting for optimum signal strength cannot readily be distinguished. It is the usual practice, therefore, to tune a receiver of this type for minimum background hiss, or for the best quality of reproduction, instead of for maximum signal strength. There is no real difficulty in this, once the operation has become familiar, and after a little practice it is quite possible to tune as accurately as with the aid of an indicator.

There is no doubt, however, that a visual tuning indicator is a help, particularly when the receiver is to be handled by unskilled members of the family. Various methods of visual tuning are possible, but methods depending upon the movement of a light or a shadow are probably the most popular. The Micromesh "Tunograph" comes under the former of these headings, for the position of a spot of light on a screen is made to vary with the strength of the signal.

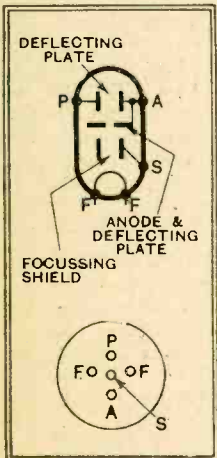

Fig. 1.—The electrode arrangement and base connections of the "Tunograph."

the deflecting plates until it finally strikes a fluorescent screen mounted at the upper end of the bulb. One focussing plate is connected internally to the anode, and the other is available for external connection. If both are maintained at the same potential, the beam of electrons strikes the screen at the extreme right-hand side, with the tube mounted vertically, and gives the characteristic green spot of a cathode-ray tube.

If the free focussing plate be now biased negatively with respect to the other, the spot of light moves towards the left by an amount which depends upon the bias, and some 40 volts is needed to bring it to the extreme left-hand side of the screen. In practice, therefore, the change

of anode current with grid bias on a controlled valve is made to deflect the spot of light, and, since the change of current increases with signal strength, the deflection of the spot is greatest for a strong signal.

The indicator is not confined to an arrangement of this nature, however, for, being practically free from inertia, the electron beam can follow the alternating signal potentials. If the deflecting plates be maintained at the same steady potential, therefore, in the absence of a signal, the spot of light will appear at the right-hand side of the screen. The application of signal potentials between the plates will then cause the spot of light to vibrate backwards and forwards in a straight line, with the visible result of a line of light the length of which is dependent upon the strength of the applied signal.

Line Indication

The circuit connections for this arrangement are shown in Fig. 2, and it will be seen that the "Tunograph" is connected across the last tuned circuit of the receiver. Since the tube has a certain capacity, this circuit will require retrimming after fitting the indicator, but this should present little difficulty. It will be found that the line of light spreads to the left with increasing signal strength, and tuning is carried out for maximum length of line.

This method of indication, while very

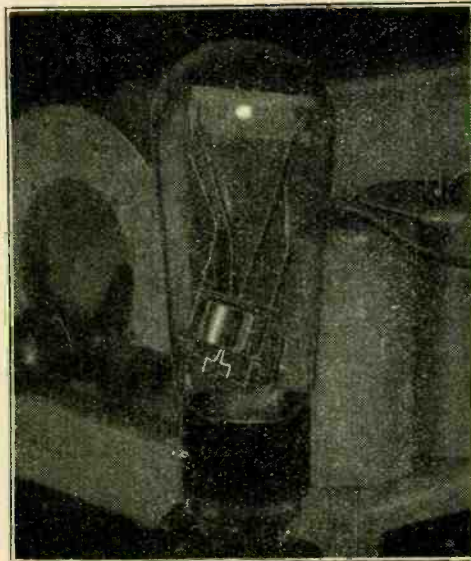

The "Tunograph" indicator, showing the light spot on the screen. As the tuning is varied to bring the set into resonance with the signal, the light spot moves to the right.

attractive from some points of view, is open to two objections in practice. In the first place, a very strong signal is necessary to give any decided line, about

13 volts for a length of 1 cm., and very few receivers are designed to operate with a detector input greater than one-tenth of this. Secondly, there is a reduction in visibility when the spot spreads out into a line, and on a very strong signal the line itself may be barely visible, and it is possible to see only a faint line with a blob at each end.

Spot Tuning

For general use, therefore, the alternative circuit, Fig. 3, is preferable, although

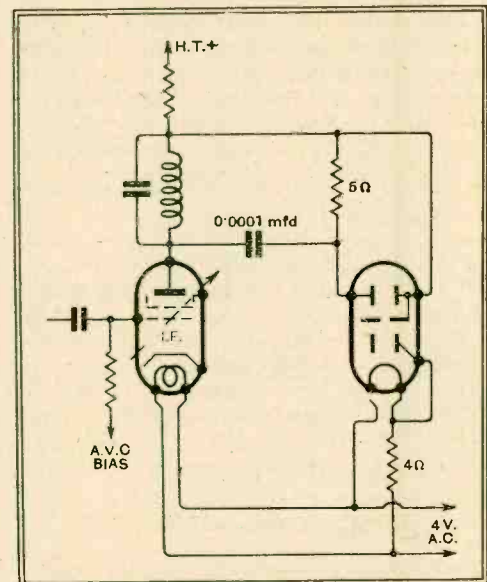

Fig. 2.—The connections for a line indication are shown here, and it will be observed that the "Tunograph" is fed from the last H.F. or I.F. tuned circuit.

this necessitates slightly more alteration to the set. A resistance of some 10,000 ohms must be included in the anode circuit of one of the controlled valves. The anode of the "Tunograph" is connected to the positive H.T. side of this, and the free deflecting plate to the other. Assuming an anode current with no signal of 4 mA., the free deflecting plate is then biased negatively with respect to the other plate by 40 volts, so that the spot of light comes to rest at the extreme left-hand side of the screen. When a signal is tuned in, and A.V.C. comes into action, the anode current of the controlled valve drops by an amount which is dependent upon the signal strength, with the result that the voltage drop across the 10,000 ohms resistance falls proportionately, and the free deflecting plate becomes less negatively biased, so that the spot of light moves to the right. Tuning, therefore, is carried out for a maximum movement of the spot of light.

The disadvantage of this method, when the tube is to be fitted to an existing set, is that the necessity for including a re-

Visual Tuning Indicator—

sistance in the controlled valve anode circuit means that its anode voltage is reduced. The value of 10,000/20,000 ohms marked on the circuit diagram is suggested by the makers; it will, however, obviously depend upon the type of valve used. Since, with no signal, a voltage drop across it of 40 volts is required, 10,000 ohms is correct for a valve taking 4 mA., and 20,000 ohms for one taking 2 mA. Some variable-mu valves, however, require 8 mA., and then the requirements are met by a resistance of 5,000 ohms. In practice, the resistance value is best determined by selecting a value such that with no signal the spot of light settles at the extreme left of the screen. When adding the indicator to a set, it will probably be best included in the anode circuit of the earliest controlled valve, for the reduction of 40 volts in its H.T. supply will probably be least felt here.

The anode potential of the "Tunograph" must be at least 180 volts, and care should be taken to see that the mains transformer is capable of supplying an additional ampere of current for the filament without an excessive drop in heater voltage on the valves. Since the filament

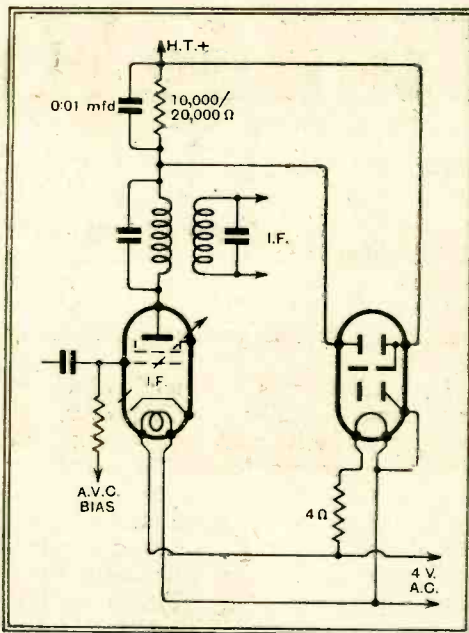

Fig. 3.—With these connections, the position of the light spot varies with the bias on the controlled valve, and hence with signal strength.

of the indicator is rated for only 0.5/0.6 volt, it must be run from the 4-volts A.C.

lines through a 4-ohms resistance rated to carry one ampere.

It should be noted that the spot of light is not readily visible in a bright light unless the tube be enclosed in a light-proof box with a viewing window. It is suggested that the tube be mounted inside the cabinet in any convenient position and a small hole cut in a suitable position on the panel for viewing. In general, it will be best to mount the tube horizontally, with the left-hand side of the plate at the bottom when using a spot indication, and the right-hand side at the bottom when using a line indication, for the spot or line will then move vertically on tuning in a signal, and the operation of tuning will be carried out for maximum height of spot or line.

It should be pointed out that the spot can be deflected by external magnetic or electrostatic fields, and a small deflection will be observed on touching the glass bulb with the finger, due to the dissipation of the charge which accumulates on the glass. It is not improbable, therefore, that the spot might move right off the screen if the tube be mounted in close proximity to a loud speaker, mains transformer, or smoothing choke.

News of the Week

Current Events in Brief Review

Despite the Depression

NEW ZEALAND receiving licences have now reached the 100,000 mark.

An Acoustic "Find"

VIENNA'S finest studio from an acoustical point of view is the small hall of the Municipal Concert Building. This has been hired by the broadcasting company for use at frequent intervals for important musical programmes.

Medium Wave Freaks

AMONG letters reporting reception received by the Brussels broadcasting stations have been reports from members of the New Zealand DX Club. It is also interesting to note that Athlone has been picked up by the same club.

Good News for Dealers

WIRELESS dealers need have no scruples in giving public demonstrations on loud speakers, despite the decision of the Court of Appeal that the public reproduction of broadcast music is an infringement of the composer's copyright. In a statement made last week, Mr. C. F. James, General Manager of the Performing Rights Society, said that the Society did not contemplate any departure from the policy hitherto followed in the matter of performances given in dealers' shops solely for the purpose of demonstrating wireless apparatus with a view to sale.

These performances, said Mr. James, were "public" for the purpose of the Copyright Act, but the Society had never concerned itself with cases of this kind and did not propose to do so now.

Changes at Munich

THE Munich high-power transmitter is to close down temporarily for constructional changes made necessary by the adoption of a new wavelength and an increase in power from 60 to 100 kW. Until January 15th next the old Munich 1.5 kW. transmitter at Stadelheim will be used.

No Pompous Oratory

ACCORDING to an interview given by M. Laurant-Eynac, the French Postmaster-General, politics will be absent in the new French broadcasting scheme.

"Polemics are out of place," said the P.M.G., "in programmes intended for the world; we shall seek a broadcasting style without pompous oratory."

Merciless war will be waged on man-made static, and by the end of November anti-interference devices will become compulsory.

Graceful Tribute from U.S.

"Q.S.T." the American amateur journal, is high in its praises of the experimenters, Messrs. O'Heffernan and Myatt, who secured the world's record for ultra-short wave communication when the former transmitted from the top of Snowdon in August last, and was heard at Hoddesdon on a *Wireless World* "Ultra S.W. Two," 200 miles away.

"If any U.S. amateur has done comparable DX from such an altitude," says "Q.S.T.," "we have yet to hear about it. Even our honest-to-goodness mountains have yet to notice such things happening around them."

Stage v. Studio

THE traditional warfare between broadcasting and the theatre assumes a new complexion with the news from Prague of an enterprising theatrical manager there, who, hearing an unusually good bass broadcasting from Warsaw, "stole" him for the purpose of his next production.

Tokio Listeners Aid Air Force

BROADCAST listeners were asked to participate in the recent aerial manoeuvres at Tokio. They were formally requested to intercept the planes' signals on their loud speakers as the squadrons passed overhead and to convey these messages "by all possible means" to headquarters.

Slower Wireless Waves?

TESTS on the actual speed of wireless waves have just been completed by MM. Stoyko and Jouanist, of the Paris Academy of Science. Despite the theoretical assumption that the wireless wave, having the same speed as that of light, travels at a rate of 300,000 km./sec., the French scientists have discovered that short waves travelling between Buenos Aires and Paris have a speed of only 270,000 km./sec. The difference of ten per cent between the theoretical and practical values may be explained by the number of reflections which the waves undergo, which would tend to lengthen the distance covered and slow down the wave. Long waves, the scientists state, travel at the speed of only 245,000 km./sec.

The Three Best

DURING the past year Belgium has registered the third highest percentage amount of listeners to density of population, her figure of 69.3 per thousand being exceeded only by Spain (108.3) and Greece (72.3). There are now in Belgium 409,000 French and Flemish-speaking listeners.

Superhet as "Also Ran"

THE Copenhagen Radio Exhibition opened with a startling declaration by the Danish Premier, M. Stauning, that the Lucerne Conference had been a failure.

As to the exhibition itself, our Danish correspondent reports that the superheterodyne receiver was not nearly so popular in Northern Europe as it appears to be in the south. Straight receivers were much in evidence, the most popular being three- and four-valve arrangements. Many British sets and components were displayed.

Banning the "Gyp"

ONE of the by-products of America's National Recovery movement will be the elimination of the so-called "Gyp" radio service men, and those who will take their place are being organised to outlaw "the vulturous class" with which the radio service field is infested.

Among the unfair practices the new code will ban are: Stealing good radio valves and replacing them with damaged ones; malicious destruction of equipment under inspection to create additional work or justify charges; use of radio service as a pretext for gaining entry into a home for illegitimate purposes; charging for services not rendered; and, finally, misrepresentation of ability.

TELSEN

PAPER MICA and ELECTROLYTIC

CONDENSERS

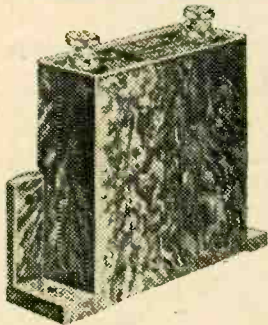

TELSEN PAPER CONDENSERS

Subjected to rigorous tests up to Post Office and Admiralty standards, the exclusive method of construction making them genuinely non-inductive. They give the highest insulation with complete freedom from breakdown—built for lasting efficiency under all conditions. Specially designed for 2-way fixing.

Cap. mfd.	500 Volt Test	1,000 Volt Test	Cap. mfd.	500 Volt Test	1,000 Volt Test
.01	- 1/3	- 1/9	5	- 1/6	- 2/-
.04	- 1/3	- 1/9	1	- 1/9	- 2/6
.1	- 1/6	- 2/-	2	- 2/6	- 3/6
.25	- 1/6	- 2/-			

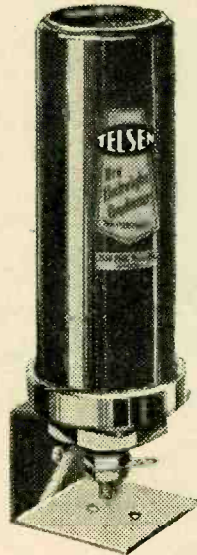

TELSEN High Voltage Dry ELECTROLYTIC CONDENSERS

An outstanding achievement in condenser design.

Excellent for use in smoothing circuits and other positions in which high voltage high capacity condensers are required. The special bracket and terminal supplied with the condenser enables it to be mounted on any type of baseboard or chassis.

Cap. mfd.	275 working peak voltage	500 working peak voltage
4	- - - - 3/6	- - - - 4/6
6	- - - - 3/9	- - - - 5/-
8	- - - - 4/-	- - - - 5/6

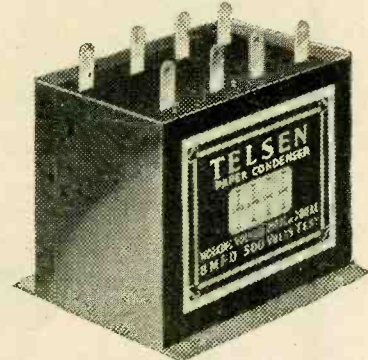

TELSEN PAPER BLOCK CONDENSERS

Represent a definite advance in current condenser practice. In metal cases with soldering tags.

Cap. mfd.	500 Volt Test	1,000 Volt Test
4	- - - 4/9	- - - 6/6
6	- - - 7/-	- - - 9/6
8	- - - 9/6	

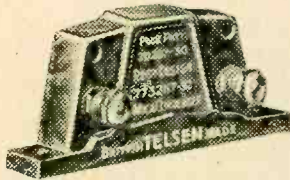

TELSEN MICA CONDENSERS

Adaptable to flat and vertical mounting. H.F. losses, even in the larger sizes, have been virtually eliminated. Grid leak clips supplied free with the smaller capacities. In capacities of from .0001 mfd. to .001 mfd. .002 - 1/- .006 - 1/3



TELSEN TAG CONDENSERS

Of compact and sturdy construction. May be mounted on either insulated or metal panels. Tags enable the condensers to be connected to any other components, either directly or by soldering. H.F. losses are negligible. In capacities of .0001 mfd. to .001 mfd. .002 mfd. 6d. **4 1/2**

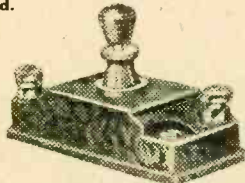

TELSEN PRE-SET CONDENSERS

Give widest variation between maximum and minimum capacities, and exceptional range of selectivity adjustment when used in the aerial circuit. High insulation with low loss. In mfd. capacities of from .0001 to .002. **1/3**

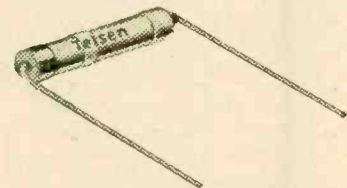

TELSEN RESISTORS WITH WIRED ENDS

Very small and light, and easily suspended in the wiring of a receiver. Supplied in the following values:— Power rating of 1/2 and 1 watt: 250, 500, 1,000, 1,250, 5,000, 10,000, 20,000, 25,000, 50,000, 100,000, 250,000, 500,000 ohms. resistance. Price **1/-**

Power rating of two watts: 250, 500, 1,000, 1,250, 5,000, 10,000, 20,000, 25,000, 50,000, 100,000 ohms resistance. Price 2/-



TELSEN Low Voltage ELECTROLYTIC CONDENSERS

Ideal where a very high capacity with a fairly low voltage is required, as in automatic bias circuits for L.F. valves. Very compact, with wired ends for easy suspension in the wiring.

25 mfd. at 25 volts	- 2/6
50 " at 25 "	- 3/-
25 " at 50 "	- 3/-

TELSEN SMALL TUBULAR CONDENSERS

Very small yet highly efficient, with wired ends for easy suspension in the wiring.

Cap. mfd.	Price	Cap. mfd.	Price
.0001	1/-	.002	1/-
.0002	1/-	.005	1/-
.0003	1/-	.006	1/-
.0005	1/-	.01	1/3
.001	1/-	.1	1/6

TELSEN FOR EVERYTHING IN RADIO

ANNOUNCEMENT OF THE TELSEN ELECTRIC CO., LTD., ASTON, BIRMINGHAM

Advertisements for "The Wireless World" are only accepted from firms we believe to be thoroughly reliable.

Aug. 15, 1933.
Oldham, Lancashire.
Aug. 5, 1933.

Dear Sirs,
It may interest you to know I have had a "Pertrix" 100 volt battery Bat. No. 272, in continual use, on a two-valve set, since November 1931 until now. I have replaced it with one of your 120 volt batteries, and am anticipating equally good results.
Yours faithfully,
Morris.

Newcastle,
Mar. 1, 1933.
Dear Sir,
On February 1st, 1932, I bought a Pertrix—100 V Sup Capacity H.T. Battery, for a three-valve S.G. set, and now for time in 13 months it is showing signs of age.
Really remarkable.
Yours,
West Hove, Sussex.
Feb. 11, 1933.
I purchased on the 22nd, a Pertrix 120 V. It is now exact. Reception is in spite of the year's hard wear. Really First Class battery such as a Pertrix, could successfully withstand such a severe test.
I am, yours sincerely,
Albert E. Burrows.

25, 1933
Dear Sirs,
I am writing to tell you I am using one of your 60-volt High tension batteries on a 3-valve wireless for this last 2 years and it is working my set. I have spoken to my friends about the wonderful battery we have and they think it marvellous.
Yours truly,
G. Madin.

Why do Pertrix Batteries last so long?

LETTERS like those above keep rolling in. Users tell us how their Pertrix Batteries have lasted—let us tell you why.

Pertrix Batteries use a neutral electrolyte which is patent to Pertrix alone, which conserves the inside of the battery—there is no 'shorting' between the cells—there are no resistance crystals formed. You can listen every day or only once a week—your Pertrix will give the same hours of service: a Pertrix Battery does not waste away when the set isn't working, in fact it gathers power for the next time its service will be needed.

For keeping your set in good voice, fit a Pertrix—the Battery that keeps on keeping on. There's a Pertrix to fit every set; and for tireless

FIT

PERTRIX

TRADE MARK

Low Tension work, fit a Pertrix Accumulator.

FOR GOOD

BRITISH MADE BY BRITANNIA BATTERIES LIMITED, 233, SHAFTESBURY AVE., LONDON, W.C.2

Mention of "The Wireless World," when writing to advertisers, will ensure prompt attention.

BROADCAST BRIEVITIES

By Our Special Correspondent

Private Line

THE private telephone line between Broadcasting House and the H.M.V. studio at St. John's Wood has proved very useful of late, not only for the preparation of records of B.B.C. studio performances and recitals on the Concert Hall organ, but in the making of the new form of "trailer" which Mr. Val Gielgud resorted to in presenting his talk on "Radio Drama" the other day.

The Radio "Trailer"

Mr. Gielgud was copying film methods when he gave us a vivid minute taken from a forthcoming radio thriller; in other words, he gave us a trailer, as the film folks call such episodes, which was actually recorded by H.M.V. and broadcast from the gramophone record specially for the occasion.

The episode was acted at Broadcasting House and was recorded over the H.M.V. land line.

Droitwich Testing Next Spring

THE mast riggers' strike notwithstanding, the B.B.C. hope to have the Droitwich transmitter testing next spring. It has now been decided that the two 700ft. masts shall sustain a single "T" aerial.

The Post Office Will Oblige

As I predicted a few weeks ago, the available power will be far in excess of the nominal 100 kW., though this is the maximum for which the station will be licensed. However, as is known by those who have had any dealings with the General Post Office headquarters staff, these officials can be very accommodating in matters of this kind, and I do not doubt that, if circumstances require it, the B.B.C. will be granted permission to use a greater aerial output.

A power of 100 kW. will seem small next year if the present plans of many of the European stations come to maturity.

Good-bye to "No. 10"

IT is now fairly definite that the New Year will see the closing down of the Wharf Studio, "No. 10." The alterations to Waterloo Bridge will involve so much noise that the programmes are likely to be interfered with; moreover, there are other reasons to bring about the B.B.C.'s departure.

Skating Rink?

In all likelihood the Corporation will then resort to the skating rink in Delaware Road, Maida Vale, to which first reference was made in these columns on September 1st last, when an exclusive photograph of the suggested building was published. There is, however, a remote possibility that the B.B.C. authorities may use the H.M.V. studio at St. John's Wood for the now famous "Music Hall" programmes, and they also have their eyes, I am told, on the Small Queen's Hall. But the odds are in favour of the skating rink.

Trafalgar Day

NINE scenes and forty speaking parts are comprised in a forty-five minutes' broadcast on October 21st in celebration of Trafalgar Day. The programme is drawn from "The Dynasts" by Thomas Hardy, and one scene is set in the cockpit of the *Victory*, where Nelson died.

For Quality Lovers

IF a ballot were held to decide which is the favourite B.B.C. orchestral combination, I believe that the B.B.C. Theatre Orchestra would win a high place, especially among those listeners who concentrate on quality reproduction. For there is no gain-saying the fact that it is these smaller orchestras that are heard to the best advantage under modern receiving conditions.

What We Hear

The Theatre Orchestra is now undergoing reorganisation under the direction of Mr.

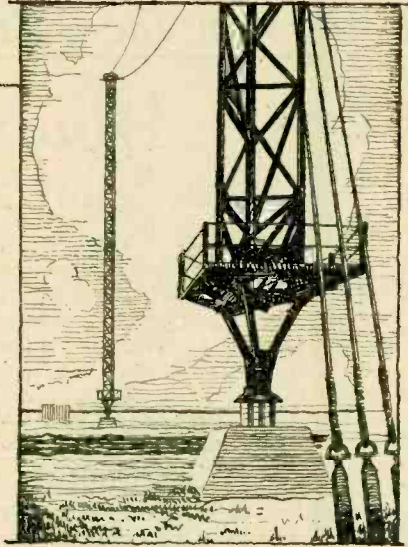

Stanford Robinson. As it is always interesting to know just what instruments are being broadcast, I append a list showing the composition of the reconstructed orchestra.

Six first violins,	One bassoon,
Two second violins,	Two horns,
Two violas,	Two trumpets,
Two 'cellos,	One tenor trombone,
One double bass,	One bass trombone,
Two flutes,	One tympani,
One oboe,	One percussion.
Two clarinets,	

"Kaleidoscope" Revived

ONE of the most haunting plays ever broadcast was "Kaleidoscope," representing the life of a man from the cradle to the grave. First heard five years ago, this play was a brilliant example of the fertile imagination of the author, Lance Sieveking. It was the earliest play of its type, and it is only fitting that it should figure in the festival of radio drama now running.

Listeners to the National programme will hear the revival on October 27th, and it will be heard by Regional listeners on the following evening.

Synchronisation Phenomena

IT is now just possible when listening in certain of the outlying areas to observe the effects of synchronisation between West National and London National. Listeners have written to the B.B.C. complaining of "wavering" on sustained notes similar to that occurring on a swinging gramophone record, this beat note being caused by minute phase variations.

But considering that, according to the B.B.C., only three listeners have complained on this point, it might be premature to describe the experiment as a failure. However, the engineers, with the cautiousness of their tribe, declare that the trouble may be more pronounced with the approach of winter.

Wales Changes Her Tune

Taken as a whole, West Regional station seems to be giving great satisfaction—too great, in fact, in South Wales, where many listeners report that they are swamped by the two transmitters.

This has its amusing side when one remembers the pother which arose in Wales when it was decided that West Regional should occupy a site on the other side of the Bristol Channel. Wales scented neglect on the part of the B.B.C., but that particular form of grouse seems to have died the death.



RADIO CITY, NEW YORK, is equipped with this special Air Controlling Plant, whereby the ventilation of each studio can be checked at any moment and changed to suit requirements. There are 64 dials. It is stated that four generators in the basement can produce "900 tons of refrigeration in 24 hours."

Letters to the Editor:—**Double-channel Transmission****Electricity Charges; Valves or Stages; Aerial Overhaul**

The Editor does not hold himself responsible for the opinions of his correspondents

Double-channel Transmission

IT may be of interest to know of some experiments which I have conducted in connection with Double-Channel Transmission or Binaural listening. Using two non-directional microphones 6in. apart, the currents were taken through separate amplifiers to "A" type Brown's earpieces. A switch was provided so that the two channels could be put in parallel. The increased spread of the orchestra when listening binaurally gave an effect very similar to that experienced when the frequency scale of the reproducing system was increased, the separation of the instruments being much greater. Binaural listening was undoubtedly much more realistic than when using a single channel. In order to ascertain whether it was necessary for the two channels to have identical frequency response curves, one of the Brown's earpieces was replaced by a cheap earpiece of the large iron diaphragm type having a very low natural resonance. Although the resulting frequency characteristic of the two channels were totally different, the advantage of binaural listening was still retained.

With regard to binaural listening through loud speakers, this presents a fundamental difficulty, inasmuch as for true binaural listening, the sounds which reach each ear have to be kept distinct and separate. Any loud speaker arrangement, except possibly one in which a loud speaker is fixed on each side of the listener's armchair, will have the disadvantage that the sounds from each speaker will reach both ears with comparable strength. Even in this case, the time lag if the listener's head is not central may spoil the effect, but I have not tested this question.

It would seem that the only practical way of imitating binaural listening with loud speakers is an arrangement where several microphones are spaced at considerable distances, and the reproducing loud speakers spaced in a similar manner. This arrangement will repeat at the listener's ear, more or less, the effect of the physical dimensions of the orchestra. It would be essential, however, for the loud speakers to be placed farther apart than would be possible if they were both included in a cabinet of the ordinary size.

P. G. A. H. VOIGT.

Upper Norwood, S.E.

Wireless Sets and Electricity Charges

WITH reference to your description as "audacious" the Mexborough notice printed on page 204 of your issue of September 1st, I consider that you are being unreasonable in your demand that wireless sets should be supplied at the domestic heating and cooking rate.

A typical scale of rates of charges is:—
Lighting, 5d.

Power, 3½d. for first 500 units.

After-hour shop lighting, 2d.

Domestic cooking and heating, 1½d. for first 200 units.

Water heating, ½d. (cut off during peak load).

You might as well demand to couple wireless sets to the water-heating meter!

Probably 50 per cent. or more of supply authorities have, as a considered policy, a different scale for power from that for domestic heating and cooking.

A house using 600 units a quarter for heating and cooking would, on the sliding scale, get such current for 1d. a unit, whereas a factory would have to use 40,000 units per quarter on the power sliding scale to get down to 1d. a unit. Such seeming inequality can be strongly defended.

The basis for these different rates, depending on the filling up of "troughs" in the load line and the general raising of both load line and load factor, is a complicated business into which there is no occasion to go here, as the general principle remains established and sound economically.

By the majority of supply authorities it is stipulated that the domestic cooking and heating rate is not applicable to domestic power, e.g., a motor for pumping from the house's own well, or for working a lathe,

from the power (or lighting) supply, and not from the heating, notwithstanding that an electric fire may be employed as the dropping resistance.

Is not your attitude—which apparently is not fully supported by the electrical Press—based on your incorrect conception of "power" wiring in private houses, whereas such wiring, other than the lighting wiring, is nearly always "heating or cooking" wiring?

That the power used in wireless sets heats the cathodes is no more relevant than the fact that a motor is heated by its current.

I agree with you to the extent that wireless sets and clocks should be supplied at power rates if the owner is agreeable to be so separately metered and to be charged the appropriate meter rent and minimum charges, but I think most would find it cheaper to revert to being charged at lighting rates, as in the cases of householders who only use an iron for an hour a week.

Anomalies are bound to crop up in detail of electrical charging, as electricity cannot be stored to the same degree as gas or water, and many lighting consumers are unable to grasp why they should pay more than the power scale. On these matters discussion might be interminable before conviction.

Staffordshire.

COLONEL.



A spot-welding process in the manufacture of the new Cossor DD/PEN valve.

saw, etc., for which purpose the householder has the option of demanding a separate power meter, using separate internal wiring. With the high rate for a small quantity of power, coupled with a fixed half-yearly minimum charge and capital outlay on wiring, it would often pay the consumer to take such power through his lighting meter.

Strictly, in such cases, a vacuum cleaner, sewing machine motor, etc., should be charged at power rate, but many authorities might condone, though not approve, such small current-consuming devices being served from a heating plug.

In the same way the charging of accumulators for car or wireless purposes must be

Correspondence, which should be as brief as possible, should be addressed to the Editor, "The Wireless World," Dorset House, Stamford Street, S.E.1, and must be accompanied by the writer's name and address

Valves or Stages?

WE must agree, on reading the letter from Ferranti, Ltd., that neither by valves nor stages can we satisfactorily describe a receiving set, seeing that we have passed the time when each valve is a general-purpose valve with the same characteristics.

It seems to me that the abilities of a set are best described by giving first the maximum possible amplification (allowing, say, 5 per cent. distortion) expressed as a ratio between aerial input and L.F. output, and, secondly, the output in watts of the last stage.

Other facts, such as consumption, frequency range, whether volume automatically controlled and so on, would also be added, of course, and amongst them could be given the number of valves and their type.

Ipswich.

PENSEMULO.

Importance of Aerial Overhaul

THE importance of aerial overhaul to which you have drawn attention in recent issues cannot be too strongly stressed.

I made the following experiment some time back: On test, an aerial showed a reading of 2 megohms at 500v. D.C. The insulators were cleaned with carbon tetrachloride, the liquid was then filtered through a one inch square of blotting paper. The paper was then heat dried to expel any moisture, and a test made from two opposite corners. The result was a dead short.

If properly erected an aerial should give a reading of infinity, and this insulation can be made to hold good even in a storm of rain.

J. P. J. CHAPMAN.

Bournemouth.

Ferranti "Lancastria" Superhet

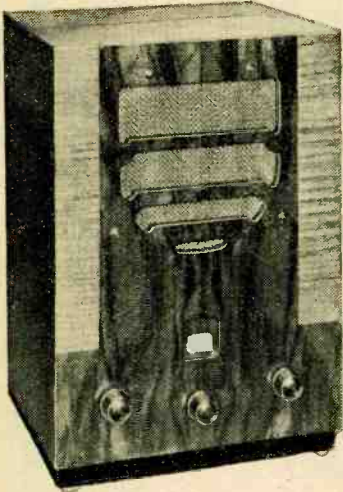

FEATURES. *Type* :—Self-contained table model superheterodyne receiver designed to work from A.C. mains on an external aerial. *Circuit* :—Detector oscillator with band pass input and image rejector circuit—I.F. amplifier—second detector (diode triode)—triode output valve. *Controls* :—(1) Tuning with illuminated wavelength scale. (2) Volume Control. (3) Wave-range and on-off switch. *Price* :—15 guineas. *Makers* :—Ferranti, Ltd., Hollinwood, Lancs.

A Compact Receiver with Excellent Volume and Range.

ALTHOUGH the overall dimensions of this set are only 15½ in. × 10½ in. × 9 in., it is anything but a "midget" set in performance. With an energised moving-coil loud speaker and a power valve capable of an undistorted output of 2½ watts, the volume and quality would do credit to a small console radio-gramophone. The fullness of the bass response is particularly impressive for a cabinet of such small size, but there is no undue suggestion of resonance in this region. If reasonable care is taken in tuning, a very satisfying balance of tone is obtained over the frequency range, which extends well into the upper register.

The receiver is a four-valve superheterodyne, and the components have been designed and assembled with unusual skill, so that, although the overall dimensions of the chassis are small, there is no evidence that anything has been skimmed.

The chassis as a whole is mounted on sponge rubber blocks to minimise microphonic noise, and special care has been taken to ensure immunity from electric shocks. The valves at the back of the cabinet are enclosed in cylindrical screens, to which access is obtained only after removing the channel-section cover plate.

There are three controls, the one in the centre operating the illuminated wavelength scale, that on the left combining the wave-range and on-off switch, and the one on the right the volume control. The sensitivity of the set is such that it is rarely necessary to make full use of the latter control, and Langenberg in daylight can be brought up to full loud-speaker volume with

the control set at a little more than the half-way position. The wave-range control knob does not carry any indication marks,

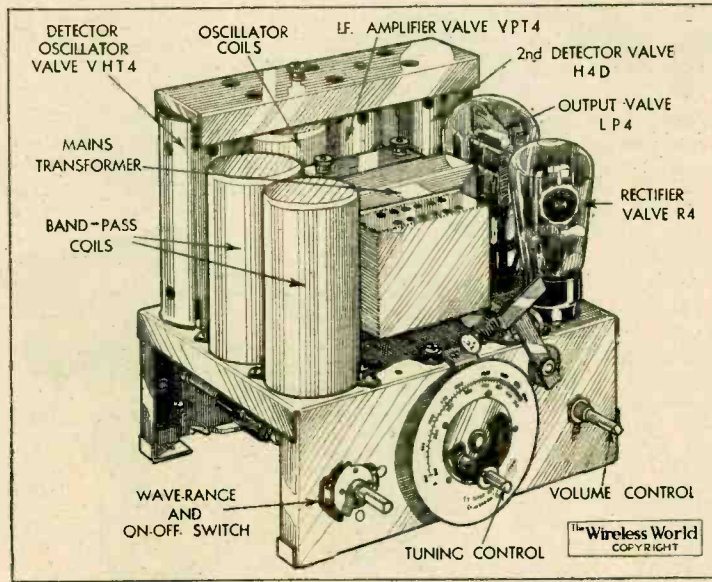

The "Lancastria" chassis is a model of compact design.

neither has switching for the gramophone pick-up been included, and the necessary change in the circuit must be made by removing the tag from the pick-up terminals at the back of the set.

The selectivity is remarkably good for a set of this type, and in Central London it should be possible to receive stations on

the channels adjacent to the London National transmitter. Owing to the slightly higher signal strength of London Regional, it was barely possible to obtain adjacent channel selectivity, but there can be no doubt that an increase of distance of five miles or so from the station should bring this feat within the capabilities of the set.

The selectivity on long waves is equally good, and the reception on this range is notable for the absence of background noise.

There is very little interference due to second-channel whistles, and the only one which could be traced was in the neighbourhood of 500 metres and did not coincide with any important station. A special balancing circuit has been included in the input band pass filter to neutralise this type of interference.

The first valve in the circuit is the Ferranti-type VHT4 "heptode," which combines the functions of oscillator and first detector. It is followed by an intermediate frequency amplifying stage which includes four tuned circuits. The output from this stage is rectified and amplified by the Type H4D double diode triode, the two electrodes of the rectifier being bonded together, as automatic volume control is not included in the specification. Resistance coupling is used between this valve and the Type LP4 triode output valve which, as mentioned above, is designed to give an output of 2½ watts.

The power supply circuit follows normal practice, and the smoothing is efficient.

This is a receiver which clearly demonstrates that a high standard of performance does not presuppose a cabinet of bulky proportions, and it will go far to remove the prejudice which exists in some quarters against so-called "midget" sets.

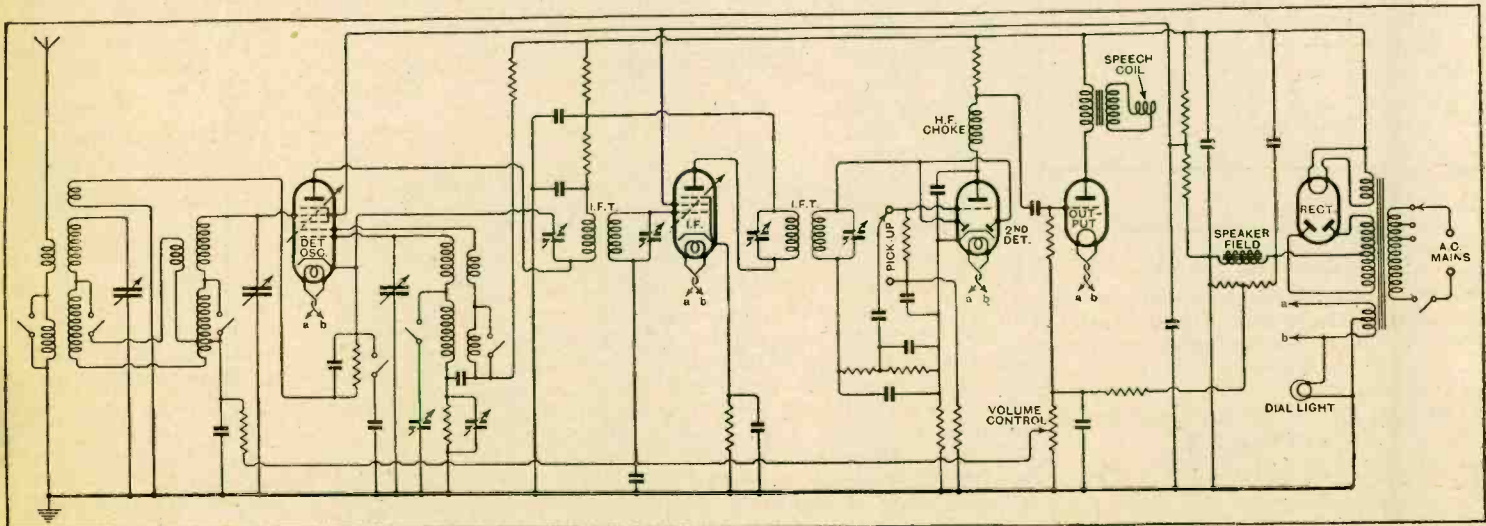

Complete circuit diagram. A heptode valve is used as a frequency changer and a diode triode in the second detector stage.

New Apparatus Reviewed

BRITISH RADIOPHONE I.F. TRANSFORMER

THE superheterodyne I.F. transformer made by British Radiophone, Ltd., Aldwych House, Aldwych, London, W.C.2, is of the fixed band width type, as provision is not made for varying the coupling between the coils. From tests made with some specimen transformers it would seem that optimum coupling is adopted as one peak only appears on its response curve.

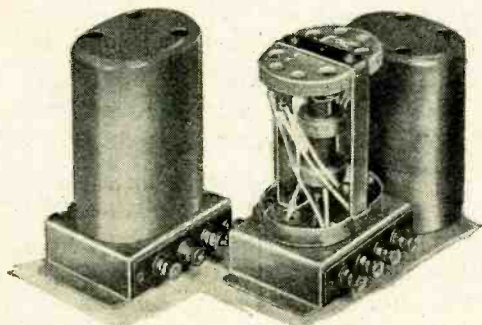

British Radiophone 110 kc/s I.F. transformers: one with cover removed.

High selectivity will, therefore, be a feature of all I.F. amplifiers in which this transformer is included, but a measure of tone correction will be desirable, and this may be obtained either by the use of a pentode output valve or by a tone compensated stage in the L.F. amplifier.

Both primary and secondary windings are tapped, that on the former giving an alternative connection for the anode of the preceding valve, while the secondary tap can be utilised to relieve this circuit of detector damping.

The small trimmer condensers are mounted above the coils, and access to their adjusting screws is given by holes in the aluminium cover. These condensers provide sufficient latitude to tune both circuits accurately to 110 kc/s under all conditions. Three terminals joining to inner, outer and tapping point respectively of each winding are mounted on opposite sides of the base, and the price is 10s.

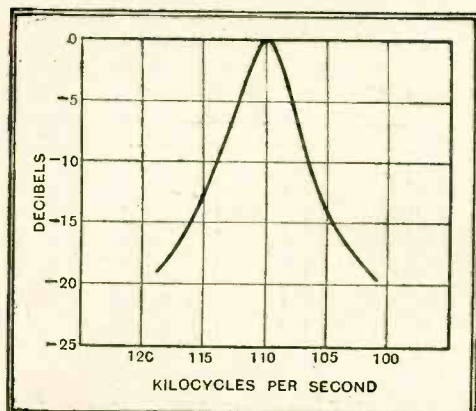

Response curve of British Radiophone I.F. transformer using anode tapping on primary winding.

POLAR STAR MINOR SUPERHET CONDENSER

THE new range of gang condensers recently introduced by Wingrove and Rogers, Ltd., Arundel Chambers, 188-189, Strand, London, W.C.2, and known as the

INTERESTING RADIO PRODUCTS

Star Minor models were developed to provide an efficient and accurately matched condenser unit in compact form. The three-gang model, for example, requires a baseboard space of 6in. x 4½in. including the drive, and the overall height is 4½in.

Rigid steel frames with the rotors carried in bearings of adequate size and entirely free from end-play and trimmers mounted on the top for accessibility constitute a few of the principal features of the new models. In the superheterodyne types the front section is fitted with tracking vanes shaped to maintain a 110 kc/s frequency separation with the pre-selector circuits when employed with coils of 157 m-henrys for medium waves and 1,900 m-henrys for the long waves in signal frequency circuits and 126.5 m-henrys and 925 m-henrys respectively for the oscillator coils. On long waves a series padding condenser of 0.002 mfd. is specified to give correct tracking. This should be semi-variable.

Tests made with a three-gang type show very good matching between the two sections of equal capacity. At one part of the scale only was the makers' tolerance

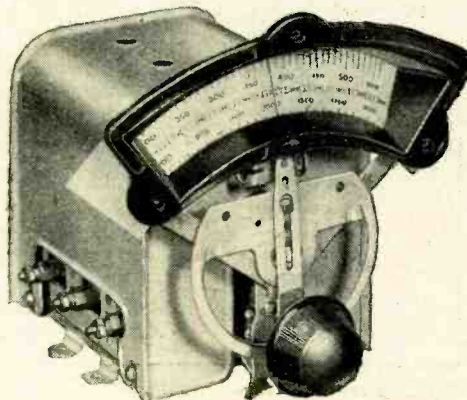

Polar Star Minor Superhet three-gang condenser.

of one half per cent. plus or minus one half micro-mfd. exceeded, but even so the deviation was no greater than one per cent. of the capacity which is a quite tolerable amount.

Tracking is satisfactory when using coils of the stated inductance and with a total minimum capacity of the order of 70 mfd.; incidentally, with this minimum value the wavelength calibration of the Polar dials is then substantially accurate.

The small trimmers allow a variation of 57 m-mfd. each, while the measured minimum capacity of each 0.0005 mfd. section is 20 m-mfd. A three-gang model costs 18s. 9d. and a four-section type 25s.

RONNIE SCIENTIFIC EARTH TUBE

THIS earthing device consists of a perforated copper tube 12in. long and 1in. in diameter, fitted at one end with a stout gunmetal ferrule and at the other with a cup-shaped head, also of gunmetal, and to which is attached a terminal for the earth wire. The tube is filled with a special mineral compound, actually a preparation of copper sulphate, which possesses the property of attracting and absorbing moisture.

Ronnie chemical filled earth tube and carton of special mineral compound.



Its particular function is to lower the resistance of the earth connection, thereby improving the aerial system and so enhancing the performance of the receiver. The chemical is not only very hygroscopic, but it is also of a deliquescent nature, for even on the driest of days it absorbs moisture so rapidly that within a few hours it is in a liquid state and remains so indefinitely.

In order to assist the initial percolation of the chemical after the tube has been sunk in the ground a little water should be poured into the cup-shaped head. This will find its way out through the holes carrying with it the chemical into the surrounding soil. If during exceptionally dry weather some water is poured occasionally into the tube, or on to the ground in the immediate vicinity, it will assist in maintaining a good earth connection.

The price is 5s., and the makers are Ronnie Engineering, Crewdson Road, London, S.W.9. The special chemical is available separately in cartons containing sufficient to treat an existing earth at 1s. 3d.

METAL CHASSIS FOR NEW MONODIAL SUPER

PROSPECTIVE constructors of the New Monodial Super receiver may be interested to learn that metal chassis for this set can now be obtained from the London Radio Development Services, 56, Hazel Road, London, N.W.10. They are made of 18 S.W.G. sheet steel, aluminium finished, and with holes drilled according to specification.

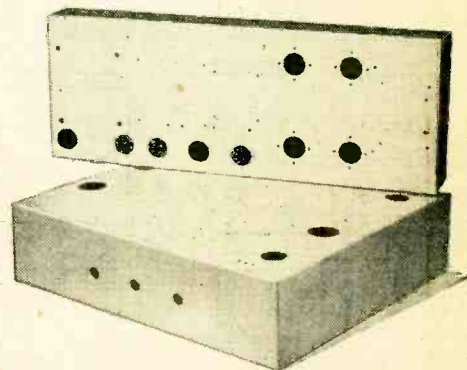

Receiver and power pack metal chassis for new Monodial Super, made by London Radio Development Services.

The receiver chassis is a full 12in. x 14in., and that for the power pack a shade over 18in. long x 6½in. wide. Fixing lugs, tapped to take 2BA screws, are fitted at each corner, and the price is 10s. 6d. for the receiver chassis and 7s. 6d. for the power pack chassis.

Perfect in design...Peerless in performance

INCORPORATING DELAYED AUTOMATIC VOLUME CONTROL



This new EKCO Super-Het Console incorporates the wonderful 7-stage Super-Het Circuit of Model 74 and is available for A.C., D.C., and Battery operation. Housed in a handsome, modern cabinet with a highly polished two-tone satin-walnut finish and ebony beading, it has already become a very popular favourite.

British and Continental stations received at full programme strength with unsurpassed fidelity—**DELAYED AUTOMATIC VOLUME CONTROL** in All-Electric Models ensures desired volume from both distant and local stations—One Knob Control—**CLASS "B" OUTPUT** in Battery Model permitting "All-Electric" performance — Band-pass tuning — New Station scale with names and wave-lengths — Light-Beam and Shadow station selector — Combined on-off switch and volume control for radio and gramophone — Moving-Coil speaker—Gramophone pick-up sockets with switch—External speaker connections.

Model

C. 74

18 guineas

or by 12 monthly payments of £1 14s. 9d.

EKCO

To E. K. Cole, Ltd., Dept. W.28, Ekco Works, Southend-on-Sea.

A full coloured folder will be sent to you free on receipt of this coupon.

Name

Address

RADIO

Send coupon for full details

MISCELLANEOUS ADVERTISEMENTS

NOTICES.

THE CHARGES FOR ADVERTISEMENTS in these columns is 12 words or less, 3/- and 3d. for every additional word.

Each paragraph is charged separately and name and address must be counted.

ADVERTISEMENTS for these columns are accepted up to FIRST POST on MONDAY MORNING (previous to date of issue) at the Head Offices of "The Wireless World," Dorset House, Stamford Street, London, S.E.1. or on SATURDAY MORNING at the Branch Offices, 19, Hertford Street, Coventry; Guildhall Buildings, Navigation Street, Birmingham, 2; 260 Deansgate, Manchester, 3; 26a, Renfield Street, Glasgow, C.2

The proprietors retain the right to refuse or withdraw advertisements at their discretion.

Postal Orders and Cheques sent in payment for advertisements should be made payable to **ILIFFE & SONS Ltd.**, and crossed

Notes being untraceable if lost in transit should not be sent as remittances.

The proprietors are not responsible for clerical or printers' errors, although every care is taken to avoid mistakes.

For particulars of Box Number Advertisements and Deposit System see previous issues.

RECEIVERS FOR SALE.

W.W. Single Dial Super (battery), Osram valves; £4/10.—R. Atkin, 9, John St., Battersea. [3673]
Ferranti S.G.4, push pull output; cost £21.—If interested write 10, Dors Close, Kingsbury, N.W.9. [3674]

A.C. Baby Superhet, Ferranti M.I. Speaker, separate cabinets; £14, or best offer.—Bartlett, 624, High Rd., Chiswick. [3646]

SAVE 60%.—Most comprehensive stocks in country; list 1/4d., stamp.—Radio Mart, 19, John Bright St., Birmingham. [3652]

PHILIPS 1933 5-valve All-mains 110-250 A.C. Receiver; cost £24/3, sell £14; demonstration—5, West Side, Phone: Wimbledon 3470. [3672]

W.W. Monodial A.C. Super (original model), new, and to specification in practically all details; £11.—Particulars, Box 8332, c/o The Wireless World. [3680]

FIRST A.C. Monodial Built to Specification, as new, not been used, guaranteed perfect; no reasonable offer refused.—H. 4, Denver Drive, Timperley, Cheshire. [3697]

H.M.V. Model 459 Superhet. Portable Six, new December last, perfect condition; cost 17 guineas, take £9, or near offer, can be seen at Brixton.—Box 8309, c/o The Wireless World. [3645]

SUPERHET Chassis, 5 Mullard valves, Rola speaker, radiogram switch; 10 1/2 guineas chassis, 11 guineas cabinet; carriage paid; cash or c.o.d.—Pollard, 85, Fortis Green, London, N.2. [3670]

WIRELESS WORLD Receivers Built to Specification, fully guaranteed, also supplied as kits; write for quotations, trade supplied.—London Radio Development Services, Ltd., Hazel Rd., Kensal Rise, N.W.10. [3682]

MARCONIPHONE "Super-8" Superhet, with fitted directional frame aerial, complete with valves and spares, Marconiphone H.T. eliminator, large accumulator and Marconiphone loud-speaker, all in perfect condition; £8.—Box 8336, c/o The Wireless World. [3608]

TO Meet a Steady Demand for Second-hand Sets and Components we can make a very liberal allowance for these in part payment of any 1933-34 receiver or kit; any "W.W." specified parts supplied; best deliveries; don't hesitate; cash or H.P.—Macindoe and Co., 99, Waterloo St., Glasgow. [3699]

AMPLIFIER, G.E.C., 60-watt, battery operated 4 stages, portable, milliammeter circuit each stage, volume and pitch control, in teak carrying cabinet complete with 6 crates Exide special P.A. H.T. batteries, valves, microphone and control box, all new and unused, carried as a portable job during "Daily Mirror 8 Tour"; cost £150, sell £25, waiting first class "Superhet" battery or mains.—Mobile Amplifiers, 6, Conduit St., W.1. [3683]

ARMSTRONG Latest 1934 Universal 4V Chassis, incorporating 3 tuned circuits in square peak, approximately 9 kilocycles separation, giving practically super-heterodyne performance, full vision single knob tuning, combined switching, one knob controlling every operation, automatic voltage control, compensated multi-grid output, designed for perfect working on any voltage, direct or alternating current, without alteration; 75/- with 5 valves [114/-; fully guaranteed; approval willingly.—Armstrong Co., 100, King's Rd., N.W.1. [3690]

MAINS EQUIPMENT

N.P. for Battery Chargers; genuinely the lowest prices in the trade.

N.P. Send Trade Lists and New Range of Photographs; of Latest Plants.

N.P. Have One or Two Slightly Soiled Instruments; bargains: 24v. 1 amp. 55/-, 24v. 2 amp. 95/-, metal rectified; Philips 6 amp. 75/-; 75v. 6 amp., 3 circuits as new. £12/5, etc.; satisfaction or cash refunded.

N.P. Make H.T. and L.T. Chargers for Battery Stations from 62/6 to £17/10, suitable for dealing with hundreds of batteries at one time; trade list and photographs.

N.P. Advice on All Matters of Battery Charging, diagrams supplied for complete wiring of cells, plant only needs plugging in and switching on; state your needs—the season has commenced now.—Nash Products, Ltd., Stechford, Birmingham. [3664]

PARTRIDGE Transformers.—Self praise is no recommendation, but praise from experts is significant.

PARTRIDGE Transformers.—"a sound electrical job very good value," *Wireless World*, Sept. 15th.

PARTRIDGE Transformers.—"voltage regulation excellent... transformer remained remarkably cool." *Radio Trade Review*, May, 1933.

PARTRIDGE Transformers.—"found to be excellent... designed on sound lines," *Wireless Magazine*, October, 1932.

PARTRIDGE—250-0-250v., 60 m.a., 4v. 1a., 4v. 2-4a., 11/-; 250-0-250v., 60 m.a., 4v. 1a., 4v. 2-3a., 4v. 1a., 12/-.

PARTRIDGE—350-0-350v., 60 m.a., 4v. 2-1/2a., 4v. 2-4a., 13/6; 350-0-350v., 120 m.a., 4v. 2-1/2a., 4v. 3-5a., 4v. 1a., 17/3.

(This advertisement continued in third column.)

PILOT

AUTHOR

KITS

Exact to Specification

AS FOUNDERS OF CONSTRUCTOR'S SETS IN 1919, we have established a world-wide reputation for the supply of Complete Kits and Part Kits for all "Wireless World" Set designs. An essential feature of this Expert Service to the Home Constructor is IMMEDIATE DELIVERY FROM STOCK—CASH or C.O.D.—of any exclusively specified or difficult to obtain components. Rely on PETO-SCOTT, he always gives fullest satisfaction to every customer.

A.V.C. THREE

Kit 'A'—Author's Kit of First Specified Parts, including Peto-Scott Plymax Chassis and Ply Panel, assembled and drilled, less valves and cabinet.

Cash or C.O.D. Carriage Paid.

£10-15

or 12 monthly payments of 19/9.
COMPLETE KIT As Kit 'A' but with Specified Valves. Cash or C.O.D. Carriage Paid **£14-1-6**
or £2-1-6 Deposit and 11 monthly payments of 24/-.

THESE ARE THE PARTS THE AUTHOR USED:

1 J.B. "Nugang" No. 2064 3-gang variable condenser and disc drive.....	1	2	6
1 ORMOND R.307 variable condenser 0.0002 mfd.....	1	2	0
1 ORMOND R.355 knob for above.....	1	2	6
2 WEARITE "Nucleon" Coils, B.P.1, B.P.2, T.G.....	117	6	
1 MULTITONE "Toco" Transformer 4:4.....	17	6	
1 MULTITONE Tone Control Potentiometer for above.....	3	6	
1 WATMET T4 Vol. tapered Control, 250,000 ohms.....	3	0	
1 WEARITE H.F.F. H.F. Choke.....	3	6	
1 WEARITE H.F.F. H.F. Choke.....	4	0	
1 DAVENSET No. 01 Power Smoothing choke.....	18	0	
1 VORTEXION Type AC34 Mains Transformer.....	18	0	
3 CLIX Chassis mg. air sprung type 5-pin valveholders.....	3	9	
2 CLIX Floating type 3-pin valveholders.....	2	0	
2 TELSEN W.207 0.0001 mfd. fxd. cond.....	1	4	
1 TELSEN W.229 0.25 mfd. 500 v. D.C. Test cond.....	1	6	
1 TELSEN W.316 0.05 mfd. fxd. cond.....	4	6	
1 TELSEN W.227 1 mfd. 500 v. D.C. test cond.....	1	9	
2 TELSEN W.226 2 mfd. 500 v. D.C. test cond.....	5	0	
4 TELSEN W.411 0.1 mfd. 1,500 v. D.C. tubular cond.....	6	0	
1 TELSEN W.410 0.01 mfd. 1,500 v. D.C. tubular cond.....	1	3	
1 TELSEN W.408 0.005 mfd. 1,500 v. D.C. tubular cond.....	1	0	
1 TELSEN W.396 dry elec. cond. 4 mfd. 500 working.....	4	6	
1 TELSEN W.398 8 mfd. dry elec. cond. 500 working.....	5	6	
1 TELSEN W.399 25 mfd. dry elec. cond. 25 volts.....	2	6	
11 GRAHAM FARISH "Omnite" resistances, as specified.....	16	6	
1 GRAHAM FARISH Standard grid leak 2 megohm.....	9	9	
2 CLAUDE LYONS 728 on-off switches.....	3	0	
1 CLAUDE LYONS 219 single pole double throw switch.....	1	9	
4 BELLING LEE Type B terminals, A.E., Pick-up (2).....	2	0	
1 PETO-SCOTT Wood Panel 1/2 in. ply, 15 x 8 1/2 in.....	2	6	
1 PETO-SCOTT Plymax Baseboard 12 x 15 1/2 in.....	12	6	
2 0/28 No. 20 tinned copper wire; 6 lengths Bykotek, 1 length screened sleeving; wire, Paxolin, flex, etc.; screws: 19 1/2 in. No. 4 R/hd., 36 1/2 in. No. 4 R/hd., 18 1/2 in. No. 4/32k. 1 1/2 in. R/hd. with nut and washers.....	7	0	

ALWAYS BUILD ON PLYMAX

PETO-SCOTT PLYMAX CHASSIS AND PLY PANEL SOLELY SPECIFIED. Plymax Chassis as specified by the Author, drilled and assembled, 18" x 10" x 2 1/2".

Cash or C.O.D. Post and Packing 1/3 extra. 15/-

FINISHED INSTRUMENT

A.V.C. THREE—Ready Assembled exact to Author's Specification with Valves and Cabinet. £17-17-0

or £2-17-0 Deposit and 11 monthly payments of 30/-

RECOMMENDED

PETO-SCOTT WALNUT A.V.C. THREE CABINET

A Handsome figured Walnut Cabinet specially recommended for the A.V.C. Three. Constructed throughout with well-seasoned timber by London's leading piano craftsmen. Front ready drilled for panel controls. Cash or C.O.D. Carriage Paid. Size 15" x 12" x 8 1/2".

25/-

SEND FOR 1934 CABINET CATALOGUE

IMMEDIATE DELIVERY CASH - C.O.D. - H.P.

FOREIGN ORDERS. Send one-third value of goods with order. Balance (including forwarding charges) payable to our forwarding agents on delivery. Insurance effected if desired. All orders carefully executed and expertly packed by special expert staff.

PETO-SCOTT CO. LTD.
77, CITY ROAD, LONDON, E.C.1.
West End Showrooms: 82, High Holborn, London, W.C.1

Mains Equipment.—Contd.

(This advertisement continued from first column.)
PARTRIDGE—425-0-425v., 120 m.a., 4v. 2-2 1/2a., 4v. 3-5a., 4v. 2a., 20/6; 500-0-500v., 100 m.a., 4v. 2-2 1/2a., 4v. 3-5a., 4v. 2a., 21/-.

PARTRIDGE—500-0-500v., 120 m.a., 4v. 2-4a., 4v. 3-6a., 4v. 1-2a., 4v. 1-2a., 27/6; larger types to order.

PARTRIDGE—0-7 1/2-9-11v., 1-2a., 9/3; 0-15-18-22v., 1-2a.; 10/-; any other model to order.

PARTRIDGE—135v. (tapped 110v.), 90 m.a., 4v. 2-4a., 10/6; 240v. (tapped 200v.), 200 m.a., 4v. 2-4a., 13/3.

PARTRIDGE—Step-up or step-down auto transformers, 60w., 10/3; 100w., 12/9; others to order.

PARTRIDGE Chokes—6H., 500 m.a., 45 ohms, 18/6; 13H., 200 m.a., 120 ohms, 11/6; 20H., 120 m.a., 320 ohms, 9/3.

PARTRIDGE Chokes—30H., 60 m.a., 550 ohms, 7/9; 40H., 40 m.a., 700 ohms, 6/6; all constant inductance.

WIRELESS WORLD A.V.C.3 Transformer, 13/6; choke, 7/9; new Monodial transformer (competitive model), 24/-.

LARGE Power (5w. to 100w. speech) Output Transformers, for relay and P.A. work, frequency distortion within 1 db. from 50 to 8,000 cycles.

PARTRIDGE Transformers.—Trade enquiries invited.

PARTRIDGE, N., B.Sc.(Eng.), A.M.I.E.E., A.I.Rad.E. London, S.W.1. Tel.: Victoria 5035. [3660]

VORTEXION Lead Again.

VORTEXION A.C.34, used by author in construction of a V.C. Three; see also displayed advertisement, page 6.

VORTEXION, Wimbledon, for 99.9% reliable transformers.

IF You Haven't Tried Them Yet Ask Someone who has, or call and inspect complimentary letters.

GUARANTEED 12 Months, and within 5% normal and 2 1/2% super models, neat shrouding, with detachable feet, as used by Government Departments, etc., etc.

VORTEXION—New monodial transformer, 200-250, 50 cycles, 425-0-425, 120 m.a., 4v. C.T. 1a., 4v. C.T. 1a., 4v. C.T. 6a., screen primary, open type, shrouded, 22/-; super shrouded, 26/-; weight 14 lb., henry, 8/6; extra: 10 henry choke, 5/6, post 9d.; 20

VORTEXION—5-watt Monodial A.V.C. model, 400-0-400, 120 m.a., 4v. 6a., 4v. 3 1/2a., 4v. 2, 4v. 1a., super screened, 20/-, shrouded 24/-.

VORTEXION—350-0-350, 120 m.a., 4v. 2 to 5a., 4v. 2 to 4a., 4v. 2.5a.; open type 14/6, shrouded 16/6.

VORTEXION—400 or 450 or 500v., 120 m.a., 4v. 2 to 5, 4v. 2 to 5, 4v. 2 to 5; open type 19/-, shrouded 23/-.

VORTEXION—400 or 450 or 500, 150 m.a., 4v. 4a., 4v. 2.5, 4v. 2, 4v. 2, 4v. 2, core size 2 1/2 in. x 1 1/2 in., a less terminal, 30/-, open type 26/-; post 1/3.

VORTEXION Auto Transformers to B.E.S.A. Specification, 60 watts, 9/-, post 9d.; 120 watts, shrouded 12/6, open type 10/6, post 1/-; 200 watts, open 14/6, shrouded 16/6, post 1/-; 500 watts 30/-, 2000 watts £4/10.

VORTEXION 600-watt Transformers; £4/10, carriage free.

VORTEXION 30h. at 60 m.a. Chokes, 5/6; 40h. at 60 m.a., 8/6; 30h. at 150 m.a., 200 ohms, 10/6 open type 12/6 shrouded.

VORTEXION Transformers Made to Your Specification; unless wattage grossly exceeded; special quotations by return.

VORTEXION (S. A. BROWN), 182, The Broadway, Wimbledon, S.W.19. Tel.: Liberty 2814. [3686]

HOYNE'S Transformers and Chokes the Best Obtainable, perfect insulation, regulation and reliability.

HOYNE'S Transformers used by many well-known set manufacturers after testing all others.

HOYNE'S Transformers fitted with tapped and screened primaries, filaments all centre tapped, stout cast aluminium clamps and clearly marked terminal strips are fitted to all models.

HOYNE'S Components are guaranteed for one year; built to your own specification at very competitive prices.

HOYNE'S Components—The components you will eventually use, start right; a dud cannot pass the Hoyne test.

HOYNE'S A.V.C. Three 275-0-275v. 60-70 m.a., 4v. 2.5a., 4v. 4a., 12/6, post 1s.; choke, 30 henry 50 m.a., 7/6, post 6d.

HOYNE'S New Monodial Transformer, 425-0-425v. 120 m.a., 4v. 3a., 4v. 1a., 4v. 1a., 4v. 6a., 24/-, post 1/3; weight 10lb. 10 henry choke, 6/-, post 6d.; 20 henry choke, 7/6, post 6d.

HOYNE'S—250-0-250v. 60 m.a., 4v. 1-2a., 4v. 2-4a., 10/-, post 9d.; with extra 4v. 1-2a. winding, 12/6, post 1/-.

HOYNE'S Ferrocart Model—350-0-350v. 60-70 m.a., 4v. 2-3a., 4v. 2-4a., 12/6, post 1/-; with extra 4v. 1-2a. winding, 13/6, post 1/-.

HOYNE'S—500-450-0-450-500v. 140 m.a., 4v. 2-4a., 4v. 4-6a., 4v. 2a., 4v. 2a., 27/6, post 1/3; weight 11lb.

HOYNE'S—0-110-135v. 90 m.a., suitable for H.T. 6 post 7, 7/6, post 9d.; with 4v. 2-4a. winding, 9/6, post 9d.

M. J. HOYNE, Offices and Works, 8a, Gladstone Rd., Wimbledon, S.W.19. Tel.: Liberty 3303. [3647]

TANTALUM for A.C. Chargers, H.T. and L.T.—Blackwell's Metallurgical Works, Ltd., Garston, Liverpool. [3448]

A.C. Valve Charging Boards (unused), outputs 20/25/30 volts, 6 amps; list £14, for £5/10.—Jersey, Cunnor Hill, Oxford. [3675]

BIRMINGHAM RADIO MART'S Latest List; everything the contractor requires at 60% saving.—19, John Bright St., Birmingham. [3650]

CABINETS.
EPTON Leads Again!—Handsome walnut Consolelette cabinets: Regentone, 12/6; Atlas, 11/9; Alba, 14/-; Philco (unpolished, drilled), 7/6; Philco (polished, undrilled), 10/6.—Epton, 93, New Rd., Chingford, E.4. [3667]

Mention of "The Wireless World," when writing to advertisers, will ensure prompt attention.

Buy ALL Your Radio

FROM

DIRECT RADIO Ltd.

159, BOROUGH HIGH STREET.

"THE WIRELESS WORLD" A.V.C. THREE

LIST OF PARTS.

Table listing various radio components such as condensers, transformers, and valves with their respective prices in £ s. d. format.

KIT "A" (LESS VALVES) £9-13-6

Or deposit of 28/6 and 11 monthly payments of ... 18 3

KIT "B" (WITH VALVES) £13-0-0

Or deposit of 35/- and 11 monthly payments of ... 1 4 0

Recommended by Direct Radio:

Lissen 7 Valve Super Hot Chassis Model with valves £8-17-6

Lissen Skyscraper Three complete with 3 valves £4-9-6

Station Master 4 with valves £4-6-6

Atlas Eliminator type C.A.25 £2-19-6

Blue Spot 29 P.M. Moving Coil Speaker £1-12-6

Ferranti Class B Speaker Amplifier £4-4-0

Visit our Showroom at 159, Borough High Street. Write for quotation for any radio requirements. Prompt Despatch.

CASH, C.O.D. and EASY PAYMENT ORDER FORM

To DIRECT RADIO LTD, 159, Borough High Street, London Bridge, S.E.1.

Please despatch to me the following goods.....

(a) I enclose (b) I will pay on delivery (c) I enclose first payment of

NAME

ADDRESS

Cabinets.—Contd.

RADIO-GRAM Cabinets; fully illustrated list free; remarkable values—Gilbert, Cabinet Maker, Swindon. 1686

MANUFACTURER'S Clearance Lines of Cabinets for Radiograms, loud-speakers, and radio sets; hundreds to select from; send postcard, for list; special: cabinets for Skyscraper and S.T.400.—H. L. Smith and Co., Ltd., 289, Edgware Rd., London, W.2. 13409

DYNAMOS, ETC.

ROTARY Converters, 220 volts D.C. to 200 volts A.C. capacities up to 0.44 K.V.A., from £4/10—Milo Engineering Works, Milo Rd., East Dulwich, S.E.22. Phone: Sydenham 4422. 13641

E.D.O. Rotary Converter, 230v. D.C., input 230v., 50-230 watts A.C. output, in soundproof cabinet, as new; with filter unit; £10.—Apply Knights Radio Stores, Leigh Rd., Leigh-on-Sea. 13550

GRAMOPHONES, PICK-UPS, ETC.

EPTON Leads Again!—Famous Blue Flyer A.C. induction gramophone motors, with turntables, brand new (listed £6/6), few only; 29/6.—Epton, 93, New Rd., Chingford, E.4. 13669

LOUD-SPEAKERS.

B.T.H. RK Moving Coil Speakers, guaranteed new, unused, manufacturers' surplus, original price. 6 Guineas, highly sensitive and wonderful tone response, will handle up to 10 watts output, available for 6v., 100v., 200v. D.C., 30/-, also A.C. models.

2/10; carriage paid, c.o.d. or cash with order; the best value in speakers obtainable to-day.—O. H. Seekamp, First Avenue House, High Holborn, London, W.C.1. Phone No.: Holborn 6609. 13425

MAGNAVOX Loud-speaker D.C.143, 7,500 ohms, 3-ratio transformer, 10in. diaphragm; £1/10.—Box 8304, c/o The Wireless World. 13642

10/—Lamplugh Silver Ghost, 2,200 ohms, with output transformer, unopened; list 47/6; c.o.d., carriage paid. Kay 167, City Rd. London. E.C.1. 13551

30/—B.T.H. R.K. moving coil speakers, 6in. cone, new and unused, guaranteed; these speakers are the type as used in cinema sound equipment; suitable for public address work; weight 30lb., and vastly superior to the cheap speakers now on the market, 100 volts, 150 volts, and 200 volts D.C.

27/6—6-volt D.C. speakers, as above; £2/7/6 speaker as above for 100-250 volts A.C., complete with field rectifier.

B.T.H. Transformers, brand new, ratios 1-1, 2-1, 20-1, and 30-1 microphone; 7/- each.

CARRIAGE Paid, cash with order, or c.o.d.—Ward, 12, Tredegar Rd., Bow, E.3. Tel.: Advance 3668. 13687

CHAL-ELECTRIC Offer New Boxed Set Manufacturers' Surplus Radio Speakers, all fitted hum buckers, state for power or pentode: F6, 110-175v. (2,000 ohms), 90-130v. (2,500 ohms), 150-200v. (4,700 ohms), 200-250v. (6,500 ohms), list 35/-, at 18/- each; F7, voltages as above, list 47/6, at 25/-; permanent magnets, F6, P.M., list 49/6, at 28/-; F7, P.M., list £3, at 33/-; dual compensated (2) F6, list £3/10, at £2, or (1) F6 and (1) F7, list £4/5, at 47/-; few Class B; state requirements all goods carriage paid cash with order, or c.o.d.—Chal-Electric, 6, Conduit St., London, W.1. 13524

TRANSMITTERS.

SPECIAL Short Wave List, 14d. list.—Radio Mart (G5NI), 19, John Bright St., Birmingham. 13654

VALVES.

VALVES.—All types American screen grids, etc., in stock.—Mildmay Radio Exchange, 24, Mildmay Grove, London, N.1. 1351a

THE M.R.D. Co.'s Own New British Valves, guaranteed 6 months, carriage paid; we invite blindfold tests against any other make.

2-VOLT Range.—V.M./S.G., S.G.2, 7/6; L.F.2, H.F.2, H.L.2, R.C.2, 3/6; driver, 4/-; P.2, 4/6; Pen.2, 10/-; Class B 1 1/2 watts 9/-; 3 watts 9/-.

A.C. Range.—V.M./S.G.A., S.G.A., 12/6; H.L./A.C., L.F./A.C., 7/6; P./A.C., 8/6; Pen./A.C., 15/-; details and characteristics on request.—Mains Radio Development Co., 4-6, Muswell Hill Rd., London, N.6. 13701

THE Following English, American and Continental valves in stock; Philco, Triotron, Tungram, Hivac, and 323 valves; prompt attention.—Newman, 309, Roman Rd., Bow, E.3. 13699

EPTON Leads Again!—Triotron 8431N (A.C.S.G.), 6/6; American 236, etc., 11/6; 280, etc., 9/11. See also "Cabinets" and "Gramophones" sections.—Epton, 93, New Rd., Chingford, E.4. 13668

ALL Latest Types of Brand New American Valves, first class makes: 247s, 235s, 224s, 236s, 237s, 235s, 245s, 244s, 12/-; 227s, 226s, 280s, 245s, 9/6; 242s, 232s, 11/-; U.X.210s, 15/-; U.X.250s, 7 watts output, 16/-; 281s, 14/6; post paid, cash with order or c.o.d.—Ward, 12, Tredegar Rd., Bow, E.3. Tel.: Advance 3668. 13688

SPECIAL Offer.—Valves by world-famous Continental manufacturers, fully guaranteed, screen grid, variable mu screen grid, high magnification screen grid, low magnification screen grid, H, HL, L, RC, power, super power, directly heated pentode, directly heated power pentode; all the above standard mains type, 4/6 each; 300v. 60 milliamp. rectifier 5/6, 350v. 120 ma. 6/6, 500v. 125 ma. 7/6; the following 4 volt battery valves at 2/- each, H, HL, L, power, screen grid.—Premier Supply Stores, 20-22, High St., Clapham, S.W.4. Macaulay 2188. 13795

COMPONENTS, ETC., FOR SALE.

PREMIER SUPPLY STORES Offer the following Set Manufacturers' Surplus New Goods at a fraction of the Original Cost, all goods guaranteed perfect, carriage paid over 5/-, under 5/- postage 6d. extra (Ireland, carriage forward).

ELIMINATOR Kits, including transformer, choke, Westinghouse metal rectifier, T.C.C. condensers, resistances and diagram, 120v. 20 ma., 20/-; trickle charger 8/- extra; 150v. 30 milliamps with 4v. 2-4 amps. C.T., L.T. 25/-; trickle charger, 6/6 extra; 250v. 60 milliamps with 4v. 3-5 amps. C.T., L.T., 30/-; 200v. 100 milliamps with 4v. 3-5 amps. C.T., L.T., 49/6; 300v. 60 milliamps with 4v. 3-5 amps. C.T., L.T., 37/6.

T.C.C. Condensers, 750v. working, 2 mf. 3/6, 4 mf. 6/-, 4 mf. 450v. working 4/-, 250v. working 1 mf. 1/-, 2 mf. 1/9, 4 mf. 2/6, 1,500v. working Standoff insulators 0.5 mfd. 1/6, 2 mfd. 6/-, aqueous electrolytic 440v. working, 4 mf. 3/-, 8 mf. 3/6.

ALL the Following Lines 6d. each or 5/- per dozen: 4- and 5-pin chassis mounting valve holders; shielded screen grid or pentode leads 1-watt wire end resistances, any value; T.C.C. 0.1 condensers; on-off switches push-pull; polar ganging devices.

(This advertisement continued on next page.)

ROLA

the World's Finest Reproducers

the Speakers that Put the "Class" in Class B Amplification



High class radio reproduction in its highest form has always been associated with Rola reproducers. Now, this comprehensive range of Class B units ensures your getting quality Class B Amplification.

For MULLARD P.M. 2B, B.T.H. PD220, COSSOR 220B, STANDARD 13B1, HIVAC B220, MARCONIPHONE B21, G.E.C. B21, CLARION B22.

ROLA FR5 PM 33—Class B ... 29/6
ROLA FR6 PM 23—Class B ... 39/6
ROLA F6 PM 23—Class B ... 49/6
ROLA F7 PM 23—Class B ... 60/-

For COSSOR 240, FERRANTI HP2, CLARION B24.

ROLA FR5 PM 32—Class B ... 29/6
ROLA FR6 PM 22—Class B ... 39/6
ROLA F6 PM 22—Class B ... 49/6
ROLA F7 PM 22—Class B ... 60/-

All Prices include Transformer.

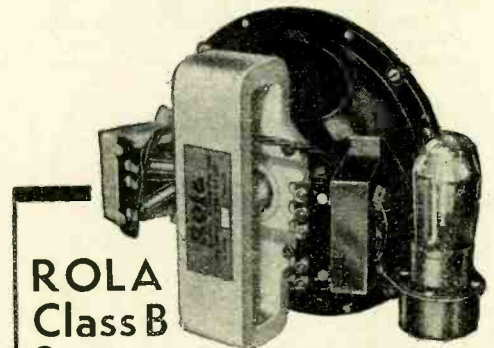

ROLA Class B Speaker Amplifier Unit

Without alteration to his set any battery set owner can increase its volume about 5 times in 5 seconds by connecting this outstanding Rola unit.

Model A—For Mullard P.M. 2B, B.T.H. PD220, Cossor 220B, Standard 13B1, Hivac B220, Marconiphone B21, G.E.C. B21, Clarion B22. Model B—For Cossor 240, Ferranti HP2, Clarion B24.

PRICE (Both Models less Valve) 57/-

EXTENSION SPEAKERS

There is a correct Rola Extension Speaker for practically all British radio receivers. Write for list.

THE BRITISH ROLA CO., LTD.

MINERVA ROAD, PARK ROYAL, N.W.10

Phone: Willesden 4322-3-4-5.



TWO POINTS about HARTLEY - TURNER

1. Dozens of people who visited the Manchester Show told us that the HARTLEY - TURNER SPEAKER sounded far more realistic than any other speaker there.

2. Dozens of people discussed "good reproduction" with us. More than ever we realised that the most ardent amateur seekers after realism have usually still a long way to go before getting really faithful reproduction.

HARTLEY-TURNER users have got it. They took the trouble to come and tell us that our speaker is "SIMPLY WONDERFUL." IT IS; and "New Notes in Radio" (sent for a 1½d. stamp) tells you all about it.

Demonstrations any time by appointment.

HARTLEY - TURNER RADIO LTD.
Thornbury Road, Isleworth, Middlesex
Telephone: Hounslow 1854.

ELIX CHEAPEST PERFECT CONTACT

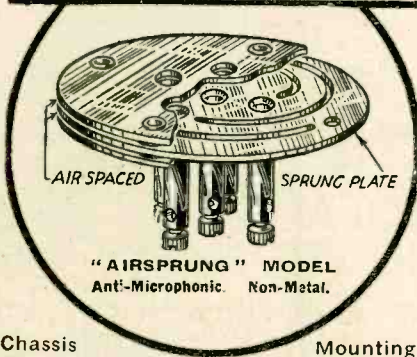

Chassis Mounting VALVEHOLDERS Specified for the "A.V.C. THREE"

Clix New "Airsprung" Anti-microphonic Valveholder is designed to—

- Damp out actual physical shocks to the valve.
- Insulate the valve from consistent vibration set up by the transformer on the chassis.
- Counteract and absorb the air pulsations set up by the increased acoustic output of modern receivers.

"AIRSPRUNG" TYPE
★5-pin 1/3
4-pin 1/2
FLOATING TYPE
★7-pin 1/-
STANDARD TYPE
4-pin 8d.
5-pin 9d.
★As Specified

"A MATTER OF CONNECTION."
Clix New Folder "W" gives details of over 30 Perfect Contact Components. Write for a copy now

Lectro Linx, Ltd., 79a, Rochester Row, S.W.1

Components, etc., for Sale.—Contd.

(This advertisement continued from previous page.)
KOLSTER BRANDES Gramophone Motors, dual type, can be worked by clockwork or mains, No. 1 induction type 100-250 volts, 27/6; No. 2, A.C. and D.C. 100-250 volts, 27/6; both the above complete with all fittings and turntable.

SPECIAL Offer—Microphones by prominent manufacturer, high sensitivity, uniform response, complete with stand, transformer and battery; listed £3/15, our price 18/6.

DUBLIER Condenser, 300v. working, 4+4+2+2+2+0.1+0.1+0.1, 6/-; 1,000v. working 1 mf., 1/6.

PREMIER British Made Meters, moving iron, flush mounting, accurate; 0-15, 0-50, 0-100, 0-250 milliamps, 0-1, 0-5 amps, all at 6/-.

ORMOND Condensers, 2-gang, semi shielded; 2/6.

WESTERN ELECTRIC Mains Transformers, input 200-250 volt, output 500-500 volt, at 150 milliamps; 4v. 4a., 4v. 2.5a., 4v. 2a., 4v. 1a., 4v. 1a., massive job; 19/6.

SPECIAL Offer of Mains Transformers, manufactured by Philips, input 100-115v. or 200-250v., output 180-0-180 volts, 40 m.a., 4v. 1a., and 4v. 3a., 4/6; 200-0-200v., 4v. 1a., 4v. 3a., 4/6.

All Premier Guaranteed Mains Transformers have engraved terminal strips with terminal connections, input 20-250 volts, 40-100 cycles, all windings paper interleaved.

PREMIER H.T.8 Transformers, 250v. 60 m.a., rectified, with 4v. 3.5a. C.T., L.T., and screened primary, 15/-; with Westinghouse rectifier, 25/-.

T.C.C. 2,000+2,000 Electrolytic, 12 volts working; listed 27/6, at 10/-.

PREMIER H.T.9 Transformer, 300v. 60 m.a., rectified, with 4v. 3.5a. C.T., L.T., and screened primary, 15/-; with Westinghouse rectifier, 26/-.

PREMIER H.T.10 Transformer, 200v. 100 m.a., rectified, with 4v. 3.5a. C.T., L.T., and screened primary, 15/-; with Westinghouse rectifier, 26/-.

MAGNAVOX Magna, D.C.144, 2,500 ohms field, with humbucking coil, Pentode transformer, 17/6; complete with A.C. conversion kit, 27/6.

DOUBLE Spring Motors, made by Garrard, play five sides of 10in. record, complete with turntable and all fittings; 17/6.

McMICHAEL, 2-screen Grid Pentode Transportable 4, complete; gets many stations; 26/15.

SPECIAL Offer—Accumulator chargers, input 200-250v. A.C. to charge 2- and 4-volt accumulators at ½ amp.; owing to the high efficiency of the silver oxide rectifier employed charger may be used during broadcast; 9/6 each.

RELIABLE Canned Coils with circuit; 3/-, accurately matched; dual range.

PREMIER L.T. Supply Units, consisting of Premier transformer and Westinghouse rectifier, inputs 200-250 A.C. output, 8v. ½ amp., 11/6; 8v. 1 amp., 14/6; 15v. 1 amp., 19/-; 6v. 2 amp., 27/6; 30v. 1 a., 37/6.

PREMIER Mains Transformer, output 135v. 80 m.a., for voltage doubling, 8/6; 4v. 3.4a., c.t. L.T., 2/- extra; Westinghouse rectifier for above, giving 180v. 30 m.a., 8/6.

PREMIER Mains Transformers, output 250-0-250 volts 90 m.a., 4v. 3.5a., 4v. 2.3a. (both c.t.), with screened screened primary, 15/-.

PREMIER Mains Transformers, output 350-0-350 volts, 90 m.a., 4v. 3.5a., 4v. 2.3a. (both c.t.), with screened primary; 15/-.

PREMIER Mains Transformers, output 400-0-400 volts, 100 m.a. 4v. 4.5a., 4v. 2.5a., with screened primary; 15/-.

PREMIER A-to Transformers, 100-110/200-250 volts or vice versa, 60-watt, 7/9; 100-watt, 10/-.

SPECIAL Offer of Manufacturers' Type Transformers, any input, output 250-0-250 volts, 60 m.a., 4v. 1a., 4v. 3a. (both c.t.), 8/6; H.T.8 transformer, with 4v. 3.4a. (c.t.), 8/6; with rectifier, 18/6.

AMPLION Mains Transformers, input 100-250 volts, output 350-0-350 volts, 120 m.a., 4v. 5a., 4v. 2a., 6v. 1a. (all c.t.); 17/6.

FILAMENT Transformers, polished and engraved terminal boards, N.P. terminals, 4v. 3.4a., 5/-; 10v. 3a., 6/6; 12v. 1a., 5/-; 4v. 4.6a., 6/6; 14v. 4a., 6/6; 22v. 1a., 6/-; 6v. 2a., 5/-; 9v. 1a., 5/-; 35v. 3a., 15/-.

PREMIER Eliminators, input 200-250 volts, 40-100 cycles, A.C. incorporating Westinghouse metal rectifiers, output 250v. 60 m.a., S.G. and 120v. taps, 42/6; with 4v. 4a. c.t. L.T., 7/6 extra.

PREMIER Eliminators, output 150v. at 30 m.a., S.G., and 100v. taps, with 4v. 3.4a. c.t. L.T., 37/6; or with trickle charger, 42/6.

PREMIER Eliminators, output 120v. at 20 m.a., S.G., and 100v. taps, 27/6; with L.T. trickle charger incorporated, 35/-.

PREMIER D.C. Eliminators, output 120v. at 20 m.a., S.G. and 100v. taps; 13/6.

ACCUMULATOR Chargers, 200-250 volts A.C., all incorporating Westinghouse metal rectifiers; 2, 4, and 6v. at ½ amp. 2/6; 2, 4, and 6v. at 1 amp., 17/6; 12v. 1a., 27/6; 6v. 2a., 35/-; 12v. 1.5a., 30/-; 6v. 3a., 39/6; 30v. 1a., 42/6; 50v. 1a., 62/6.

B.T.H. Induction Type (A.C. only) Electric Gramophone Motors, 100-250 v.; 30/- complete.

AMPLION Moving Coil Speakers, type E.M.644, dual fields 2,500 and 5,000 ohms (100 and 200v.), with output transformer, 12/6; A.C. conversion kit for this speaker, 10/- extra.

WESTERN ELECTRIC Condensers, 250v. working, 1 mid. 1/-; 2 mid. 1/-; 500v. working, 1 mid., 1/-.

T.C.C. Condensers, 250v. working, 4x4x1 mid., 3/6; 6x4x2x2x2 mid., 37v. working, 6/11; 4x4x1, 6/-.

SPECIAL Offer of Wire Wound Resistances—4 watts, any value up to 10,000 ohms, 1/-; 8 watts, any value up to 15,000 ohms, 1/6; 15 watts, any value up to 50,000 ohms, 2/-; 25 watts, any value up to 50,000 ohms, 2/6; 50 watts, any value up to 50,000 ohms, 3/6.

WIRE Wound Potentiometers, 15,000 ohms, 1/6; Centralab Potentiometer volume controls, 50,000 ohms, 2/-; Colvestats, logarithmically wound Potentiometers, 6,000 ohms, 1/5.

FOR Callers Only.—The following valves, guaranteed new.

The Last Few Western Electric 4211-D Valves, 10v. 3a. filament, 750-1,000v. plate, 50-65 m.a., impedance 3,500 ohms, amplification factor 12; cost £5, to clear at 15/-; 4212-D, 250 watt, £3.

PHILIPS 328 Valves for L.T. Charging, 5/6; 329 Barretter lamps, 2/-.

PREMIER SUPPLY STORES, 20-22, High St., Clapham, S.W.4. Macaulay 2188. Closed 1 o'clock Wednesdays, open to 9 o'clock Saturdays. Nearest Station, Clapham North Underground. [3704

I tell you EVERYTHING

and save you
money and trouble

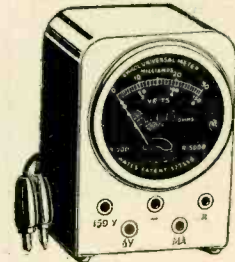

I am the EMIKOL Universal Meter. At a glance I tell you everything you ought to know about your set. All voltages, all currents, all resistances. I test every component and detect faults and distortion. No complications, no additional parts, no calculations.

Direct readings of:—

VOLTS 0 to 150

VOLTS 0 to 6

OHMS 0 to 2,000

MILLI-AMPS 0 to 30

12/6

with full instructions.

POCKET METERS.

"EMICOL"

Double reading

Voltmeter range

0-6v., 0-150v.

Price 6/-

"EMICOL"

3-in-1 Test

Meter (Wates

Patent), Range

0-6v., 0-150v.,

0-30mA.

Price 8/6

"EMICOL"

4-in-1 Test

Meter (Wates

Patent), Range

0-6v., 0-15v.,

0-150v., 0-30mA

Price 9/6

From all radio dealers, or, in case of difficulty, write direct for literature.

EMICOL BRITISH MADE

Manufactured solely by—

Electrical Measuring Instruments Co., Ltd.,
55, Cardington Street, LONDON, N.1.

WIRELESS FOR 2'11 COMFORT



No longer is it necessary to get up and down to adjust the set. From your seat anywhere in the room you can fade out uninteresting stuff to a whisper with a Modula, and by a turn of a knob adjust the volume just as you like it. A real boon to wireless users. Complete Modula as illustrated with 12 ft. cable 2/11, or with armchair leather strap 4/-. British Pix Co., 118, Southwark St., London, S.E.1.

WHAT "FREE GRID" in 'WIRELESS WORLD' SAYS:—

"The volume control functions beautifully, the 'control' being spread nicely over practically the whole movement of the knob instead of crowded up at one end as in the case of some of them."

See page 192, September 1st issue.

THE BRITISH PIX CO. LTD. (DEPT. 18),
118, SOUTHWARK ST., LONDON, S.E.1.

MODULA ARMCHAIR CONTROL

Mention of "The Wireless World," when writing to advertisers, will ensure prompt attention.

BON MARCHÉ

BRIXTON, LONDON, S.W.9

South London's Leading
Radio Store.

Phone: Brixton 6201.

Clearance of Secondhand Surplus
and Dismantled Receivers bought
by us in Part Exchange.

Unrepeatable Bargains all on
3 days' approval against cash!
Astounding Set Bargains.

CONVERTERS.—Janette, E., D.C.C., etc., 200 volts D.C. to 230 A.C.; all as new and guaranteed, worth £10, our price £4/15/- each, carriage paid. COMPONENTS.—Variable Condensers of all types, .0005 air spaced or mica without knobs, 1/- each; H.F. Chokes, all types, 6d. each; good makes. FERRANTI.—Trickle Charger, listed 55/-, 2-4-6 volts, 15/-; UMELLO Eliminators, H.T. and L.T., 120 v. Metal Case, as new, 19/6. GARRARD.—Spring Motor Single Spring on Unit Plate, Handle and Turntable, 12/6. COLLARO double Spring Motor, Unit Plate, 20/-; Utah Moving Coil Speakers, new stock 7in. Cone, 2,500 ohm Field, Aluminium type Frame, each 12/6. PHILIPS.—L.T. Charger, No. 450 6v. 1.3 amps, 10/6. PHILIPS L.T. Charger, 12 volts, 1.3 amps., 18/6. REGENTONE Eliminator for H.T., D.C. or A.C. 3 tappings, listed 55/-, our price 10/-; REGENTONE L.T. Charger, 250 volt. A.C. Input, 1 amp., 9/6. EKCO Eliminator, as new, H.T. and L.T. type C.P. 1, 19/6. RADELL H.T. Eliminator, 120 volts, 7/6. L.F. TRANSFORMERS.—Lissen, 4/-; FERRANTI AF8, 7/-; AF4, 10/-; MULLARD PERMACORE, listed 21/-, guaranteed bargain at 8/6. Telsen Baby, 2/6. TELSEN Radiogrand, 5/6. POLYMET, 4 MFD Electrolytic, 2/6 each. Fixed Condensers for smoothing, .25 MFD, 1 MFD, 2 MFD, 8d. each only. TELSEN, Titan, Edison Bell, etc. AERIAL COIL UNITS, 1/- each, all types.

SLOW MOTION DIALS, first class order, for 1/- each. CONDENSER BANKS, totalling about 8 MFD 300 v. working, 2/- each. MAINS TRANSFORMERS, assorted, 4/6 each. VALVE HOLDERS.—Benjamin, Lotus, Telsen, etc., 4 and 5 pin, 3d. each. EDISWAN MINOR Pick-ups, 10s. each. RADIOGRAM CASES (illustration on right), Mahogany finish size 38x23x16 ins., first class bargain.

18/6 each.
Carriage Forward.

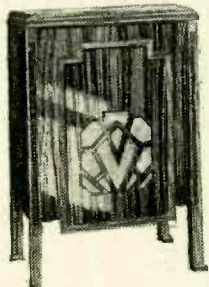

CAMCO.—Westminster Cases, Radiogram type. Beautiful Grained Walnut finish, new, listed £8/10/-, our price £4/10/- each. LINCOLN type, for Lowboy Set, listed £5/15/-, our price £3/15/- each. SIX VALVE CHASSIS, 2 H.F. Stages, detector L.F. and Power output—Long and Short Waves, Kilocycle Dial, one Knob control, combined Volume Control, and on-off Mains Switch, 11 only at special price of £5/19/6. One only PHILIPS 4 volt 4 amp. HEATER TRANSFORMER, 200/250 volt primary, first class Instrument job as new, only used for test, listed 25/-, our price 8/6 only. One only, and unrepeatable OSRAM MUSIC MAGNET 4 SET, as new, and in thorough working order, minus Valves, otherwise perfect, 2 S.G. H.F. Stages, detector, pentode, and for Battery operation, 35/- only. One PHILIPS J type Bakelite Speaker, listed at £5/5/-, our price 29/6 only. 4 only COSSOR EMPIRE MELODY MAKER RECEIVERS, complete with Valves, as new. Famous for tone, listed at £6/15/-, our clearance price, 35/- (Carriage Paid).

(Carriage paid on orders of 10/- or over.)

BON MARCHÉ Ltd.
BRIXTON ROAD, S.W.9

Components, etc., for Sale.—Contd.

R. SELECTED Parts for Sale, as new; c.o.d. or "Wireless World" deposit system, which we recommend if in doubt as to the splendid value offered; we take risk of damage in transit to our customers; goods tested for callers and guaranteed.

TO Clear.—K.B. 6v. L.R. m.c. speakers, new, 5/6; Igranic mains transformers, half watt, 550v. 60 m.a., 7.5v., new, 6/-; ditto, 250/250 100 m.a., 4v. 1 amp., 10/6; Varley 250/250 75 m.a., 3-4v., 6v., 17/6; Varley 350/350 90 m.a., 3-4v., 19/6; Parmeko 250/250 60 m.a., 2-4v., 6v., 20/-; Parmeko 275/275 3-4v., 15/9; Vortexion 250/250 120 m.a., 2-4v., 6v., 15/-; Heayberd 250/250 60 m.a., 2-4v., 12/6; I.L.T.7, with R.I. transformer and 4v. 6 amp., 20/-; all with 200/250v. input.

CLARKES Multi Tapped Pentode Choke, 10/6; Brown Vee units, new, 9/6; R.I. 14/28H chokes, 10/6, 7/14H 10/6, second-hand; sliding resistances, 5.5 ohms 3 amp., 10/6, ditto, 120 ohms 1 amp., 10/6, both first grade articles; Marconi small type DPDT switches, 25 amp., 600v., 2/9; heavy brass DPDT switches, 30 amp., 5/9; single Kantark plugs in fuse boxes, 1/-; Magnavox D.C.144, 2,500 ohm speakers, new, Pentode transformer, 22/6; British Radiophone 3-gang condensers, new, with proper cover, disc drive and all fittings, 15/9; Tritron 8 mf. electrolytic, 3/6; Polar 2-gang tubs, 6/6; Polar 3-gang tubs, 10/-.

NEW Output Transformers Similar to R. and A., ratio 18/23/32, 6/-; Telsen 0.05 mica condensers, 2/3; T.C.C. 0.01 mica type M, 1/-; new Paxolin formers, lin., slotted, with guides, 8d.; T.C.C. 2 mf., 350v. working, 1/6; ditto, 1 mf., 1/3, new; T.C.C. 4x4, 250v. working, 4/9.

PAIRS New Polar Twin 8.M. Thumb Drive, 0.0005, complete, 12/6; Telsen 100h. chokes, 3/-; Westinghouse H.T.4 and A4 rectifiers, with Varley transformers, £2; Cydon 0.0005 double thumb twin extender, 15/6; Cydon single 0.0005 extender, 7/6; Ready Radio 0.0005 extender condensers, new, 3/6; Ormond 65/- type P.M. speaker, complete, 37/6.

RADIOPHONE Pots with Switch, 5,000, 10,000, 25,000, new, 2/6 each; new type Magna speaker, 2,500 ohm and 5,000 ohm, 42/6 each complete.

FERRANTI Resistances with Holder, 3,000, 15,000, 2/6 each; Varley Power, 500, 5,000, 10,000, 40,000, 2/6 each.

TRANSFORMERS.—Ferranti A.F.4 8/-, A.F.5c 21/6, O.P.M.1c 16/6, O.P.M.2 13/-, O.P.M.4c 16/6; B1 choke, new, 13/-; A.F.6 18/6.

EDISON BELL 10,000 Eureka, wire wound, with holders, 1/-; Edison Bell 0.0005 universal log all-metal condensers, 1/6, new.

AMPLION Public Address Microphone, £3; Ready Radio Senior Instamat matching transformers, new, 10/25-1, 15/9; G.E.C. Senior induction motor, 47/6; Mullard H.T. eliminator, complete, 150v. 30 m.a., 240v. input 30/-; Six Sixty eliminator, 200v. 25 m.a., and G.B., 32/6; Ekco A.C.25, 47/6.

SPECIAL Offer of Pye 20h Chokes, 40 m.a., 130 m.a. maximum, D.C. resistance 300 ohms, in brown crystalline finish, new, unused, Pye 32h. chokes, D.C. resistance 750 ohms, 30 m.a., 80 m.a. maximum, ditto, 6/3 each, post free.

PAIR Varley Q.P.P. Input and Output, 19/-; Wearite and newcos superhet, coils, 5/-; 3-range oscillators, 7/6; T.C.C. 2,000 mf. electrolytic, 9/-; T.C.C. ditto, 250 mf., 100v., 8/6; Igranic L.F. choke coupling units, 3/9; Lotus new 4-gangs, 15/9.

RYALL'S Mains Condensers, 4 mf., 250v. working, 2/6; 4 mf., 500v. working, 4/6; 4 mf., 750v., 6/6; 2,000v., 17/6; Ryalls condenser blocks, 2-4 mf., 2-2 ml., 500v. working, 8/6; Dubilier 2x2, 500v. working, 2/6.

RYALL'S Mains Transformers, 250v. 60 m.a., 4v. 1 amp., 4v. 3 amp., 10/6; 350v., 12/9; H.T.7, with 4v. 4 amp., 10/6; 4v. 3 amp. only, 6/9; chokes, 25h. at 60 m.a., resistance 260 ohms, 6/9; 20h. at 100 m.a., 8/9; 10h. 8/9, for Monodial; 40h. at 100 m.a., 10/6.

RYALL'S RADIO Offer Reliable Resistances, 1 watt, suitable for all "Wireless World" sets where a 1 watt resistance is specified, in values 100, 500, 1,000, 2,000, 5,000, 6,000, 10,000, 25,000, 30,000, 75,000, 150,000, 250,000, 20,000, all values stated in ohms, 6d. each, guaranteed one year, wire ends, new goods.

WE Hold a Large Stock of First Class Radio Apparatus, meters, resistances, condensers, heavy chokes, and all set requirements, at bargain prices, all modern goods.

RYALL'S RADIO, 33, Chancery Lane, London, W.C.2 (nearest Tube Chancery Lane; bus 67 passes door, or tram to Savoy St.), Holborn 3529. Open Saturday afternoon. Close 7 p.m., Thursdays 1 o'clock, Saturday 6 p.m.

R. [3657]

GILBERT INDUSTRIES, Ltd.—Latest offer of parcels and components:—

COMPLETE Kit for 30 m.a., 150-180-volt A.C. Eliminator, comprising one "B" parcel as under, together with handsome cellulose finished steel case, engraved panel, plugs, wire, sleeving, solder, nuts and bolts, flex, plug, etc., and constructor's blue print, all components specially colour-coded to facilitate assembly; a £5/5 eliminator for only 30/-, post paid.

A Parcels, containing 1 steel chassis with valve holders, 1 heavy mains transformer, 350-0-350v. at 60 m.a., 4v. 6a., c.t., 4v. 2a., 1 Amco 2-gang with trimmers and 2 coils, 1 8 mfd. condenser, 1 15 mfd. T.C.C. electrolytic, 1 volume control, 1 smoothing choke 50h. 50 m.a.; complete parcel, post paid, £1.

B Parcels, suitable for building Class "B" or straight 30 m.a. 150-180-volt A.C. eliminators, containing 1 Westinghouse rectifier, voltage doubler, 1 choke 50h. 50 m.a., 4 resistances (please state mains voltage); complete parcel, post paid, £1.

D Parcels, containing 1 steel chassis, with valve holders, 1 heavy mains transformer 350-0-350v. at 60 m.a., 4v. 6a. c.t., 4v. 2a., 1 Amco 2-gang with trimmers, 1 15 mfd T.C.C. electrolytic, 1 4-4 mfd. H.M.V. block condenser, 1 volume control, 4 assorted resistances, 6 small assorted condensers, 1 Paxolin strip (10in.x4in.), 1 packet of Varcos sleeving, 6 yards heavy flex; complete parcel, post paid, £1.

R.3.3 Mains Transformers, as in "A" parcel, 12/6; heavy pattern P.M. M.C. speakers, 25/-, full volume and tone; B.T.H. Minor pick-ups, latest pattern, 25/-.

ONE "A," "B" or "D" parcels and any one 25/- article for £2, post paid.

TRADERS.—Do you realise that these parcels, when split up, will realise £3 to £4 in the shop?

GILBERT INDUSTRIES, Ltd., 519, London Rd., West-cliff-on-Sea. We are open to callers Sunday mornings.—Phone: Southend 492071. [3537]

SPECIAL Clearance Bargains.—Projectors (9, 16 and 35 mm.), 30/-; Cameras, from 20/-; everything for Movies, Walkies and Talkies; inspection invited.

ILLUSTRATED ENTERPRISES, 159, Wardour St. (facing I. Film House), London, W.1 Phone: Gerrard 6889. [3004]

SECRETS OF

CELESTION

SUPREMACY

No. 1

Acoustically Perfect Cabinets!

The cabinets in which Celestion Moving-Coil Loudspeakers are housed are acoustically designed as *part of the speaker* and not only as an attractive article of furniture. As a result, reproduction over the whole range of frequencies is of the highest Celestion quality.

It is such *attention to detail* that puts Celestion in the forefront of modern loudspeaker design. The name Celestion stands for high-quality reproduction combined with unflinching efficiency. Celestion speakers can be supplied to match any set or type of output.

Ask your dealer for a demonstration, or write for full details.

PPM 39 Cabinet Model £3-10-0
PPM 9 Chassis Model £1-15-0

Celestion Ltd., London Road,
Kingston-on-Thames.

MODEL P.P.M. 39

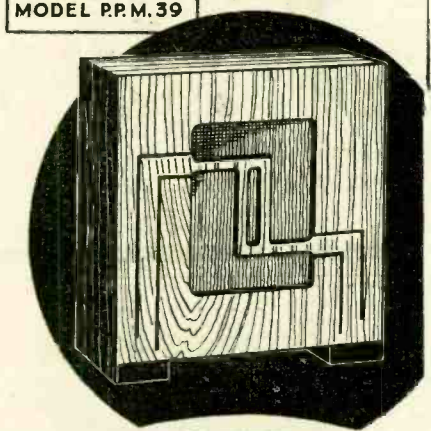

CELESTION

The Very Soul of Music

THE FOREMOST NAME
IN SOUND REPRODUCTION

SCOTT SESSIONS for

"WIRELESS WORLD" SETS

completely constructed with fine workmanship.

OVERHAULS RE-BUILDING OR MODERNISATION

TO ANY EXISTING SET

Many thousands of "W.W." readers have profited from our specialised experience during the last seven years.

Write to us now and tell us about your requirements or your radio troubles.

Our advice and estimate is free of charge.



Monodial Construction and Servicing Experts.

SCOTT SESSIONS & CO.,

Radio Engineers and Consultants, MUSWELL HILL, LONDON, N.10

Cables: "Tropiset, London."

Contractors to H.M. Government Depts., &c.

SEND FOR LITERATURE OF

Silver Ghost

Lamplugh Radio Ltd. Coventry.

Silver Ghost Reproducers MASTERS OF SOUND

BAKER

WRITE NOW FOR OUR NEW BOOKLET & LEAFLETS

75-77 SUSSEX ROAD CROYDON, SURREY

Phone: Croydon 3441-2

FOR QUALITY MOVING-COIL SPEAKERS.

Components, etc., for Sale.—Contd.

PEPPER'S Clearance Sale.
ALL Goods Must be Cleared; near offers considered; carriage paid over £2.
BBROWN Vee Units, listed 25/-, 6/11; Amplion E.M.644, 13/6; Magnavox R.5, heavy job, 14/6; Ormond 8/6 units, 4/3; Lissen, Bullphone, etc., 9d.; Ericsson 'phones, 4/11; G.E.C. unit pickup, 15/9; Phonovox ditto, 8/11.
HM.V. 2-gang Condensers, with trimmers, etc., new goods, 4/9; Astra 3-gang ditto, boxed, 8/11; J.B. ditto, R3W, complete, 9/11; ditto chassismounts, singles, 3/11; 3-gangs, 7/6; Cylodon Extensor 3-gang, 9/11; Polar Tub 2-gangs, with drive, 8/3.
WESTINGHOUSE Rectifiers, H.T.7, 7/3; 150v. 30 m.a., 6/-; 9 volts 1 amp, 7/6; H.T. chargers, 150v. at 100 m.a., 15/6; L.T. chargers, 6 volts 1 amp, 15/11; 12 volts 1 amp, 19/11; 15 volts 2 amps, 45/-.
FERRANTI, O.P.3c, O.P.4c, O.P.1, 7/6; O.P.M.6c, O.P.M.5, O.P.M.1c, 12/3; A.F.4, 5/9; A.F.6, 15/-; A.F.5c, 17/6; R.I. superstraightlines, 3/3; hypermus (second-hand), 8/6; Telsen grands, 3/11; ditto, multi ratios, 3/3; Telsen multiratio output transformers, 5/6; ditto, pentode, 4/11; ditto, 1:1, 4/11; Lewcos L.F.T.4, 3/11; L.F.T.5, 8/11.
LEWCO'S Wire Wound S.G. Controls, 1/11; ditto, L. Colvern, etc., 1/11; volume controls by Centralab, Rotor, etc., 2/3; Wearite, with switch, 3/6; ClarOstats, standard types, 2/6; Bradleyohms, E.10, etc., 2/6; Varley power potentiometers, 3/6; pickup faders, 3/11.
REGENTONE W1aS.G. Eliminators, output 150v. 30 m.a., etc., 33/6; ditto, W1bS.G., 29/6; few experimental chargers, complete, output 25 volts 1.3 amps., listed 67/6, 33/6.
DISTATONE, 3-valve H.F.-Det.-Pen., complete with Mazda valves, 39/6; another, similar, 35/-.
WESTON 301, 1,000 ohms per volt, 0-250 volts, 35/6; Filco super type testmeter, as new, 21/-; pocket meters, etc., at bargain prices.
VARLEY, E.P.9, B.P.10, 3/11 each; B.P.21, boxed, 6/3; Wearite, O.T.1, O.T.2, 0.5, etc., 5/3; Lewcos Osc.126, ExOsc.126, A.T.G., T.B.F.c, etc., 4/6; Colvern T.G.S.C., complete, 4/6; K21, K22, K23, boxed, 15/-; set K.A., K.B., K.O.C., ganged, 14/3; dual wave coils from 1/6.
GOODS Sold Under Money Back Guarantee.—Trevor Pepper, 575d, Moseley Rd., Birmingham. [3702
SOUTHERN RADIO'S Wireless Bargains.—Set manufacturers' guaranteed surplus.
MAINS Transformers.—250-0-250 volts 60 m.a., 4v. 1a., 4v. 2-4a., 11/-; 250-0-250 volts 60 m.a., 4v. 1a., 4v. 2-3a., 4v. 1a., 12/-; 350-0-350 volts 60 m.a., 4v. 2-2 1/2a., 4v. 2-4a., 15/6; 500-0-500 volts 120 m.a., 4v. 2-2 1/2a., 4v. 3-5a., 4v. 1a., 16/-; 500-0-500 100 m.a., 4v. 2 1/2a., 4v. 3-5a., 4v. 2a., 19/-; step-up or step-down transformers, 0, 100, 110, 200, 250 and 250 volts, 60 watt output 12/6, 100 watt output 14/9.
SMOOTHING Chokes.—20 henrys, 120 m.a., 320 ohms, 8/9; 50 henrys, 60 m.a., 500 ohms, 7/8; 40 henrys, 40 m.a., 700 ohms, 6/6.
ALL Mains Transformers and Chokes Guaranteed for 12 Months, specials quoted for and delivery given within 3 days of order.
VARIABLE Condensers.—Polar 3-gang 0.0005, complete with dial, knob, escutcheon, 11/- (list 35/-); Lotus 2-gang 0.0005, complete with dial knob, escutcheon, 8/6; all ganged condensers are fully screened, with trimmers and boxed; Hydra block condensers, new, 16 mid., 2-2+8+2+1+1, 1,000 volt test, 7/- each; 4 mid., 2/6; 2 mid., 1/9; 1 mid., 1/-.
SPEAKERS.—Rola F6 permanent magnet, 28/- (list 49/6); D.C. mains energised, 2,500 to 6,500 ohms, complete with humbucking coils and transformers, 16/6 (list 39/6); C.E.C. Stork speakers, complete in magnificent cabinet, 19/6 (list £3/15); Ormond speakers, complete in cabinets, 10/- (list 25/-); Ultra-permanent magnet speakers, 9/- P.M. 35/- each, a really hefty job (list 24/15); Blue Spot, 100/-, 15/6 (list 37/6).
CONSTRUCTORS' Kits.—Ready Radio "303" battery 3-valve kits, less valves, 13/- each, complete with 3 Mullard valves (P.M.1L.F., P.M.2, 2D.X.), 33/- each (list 70/-); Ready Radio Meteor screen grid 3-valve kit, less valves, 26/-; with 3 Mullard valves (P.M.12a, P.M.2D.X., P.M.2a), 49/- (list £5/7/6); Universal Radio 3-valve kits, ready assembled on chassis, 12/6 (list 45/-).
READY Radio "303" A Kits, complete with cabinet, M.C. speaker, less valves, £2/5; with 3 Mullard valves (P.M.1L.F., P.M.2D.X., P.M.2), £3/5 (list £6/17/6).
READY Radio Meteor "A" 3-valve Screen Grid Kit, complete with cabinet, M.C. speaker, less valves, £3/7/6; with 3 Mullard valves (P.M.12a, P.M.2D.X., P.M.2a), £4/10 (list £8/7/6).
READY RADIO S.T.400 Kits, as specified by Scott Taggart, £2/19/6 each (list £4/17/6); Mullard Radio for Million 3-valve A.C. kit, complete with 3 Mullard A.C. valves (Pen.4V, 354V, 84V), £3/10 (list £6/10); Mullard Radio for Million 3-valve battery kits, complete with 3 Mullard valves, £3/3 (list £6/2/6), all kit brand new in original sealed cartons.
BT.H. Senior Pick-ups, 1934 model with volume control, 28/- each (list 37/6); 6 only, B.T.H. Junior pick-ups, 17/6 (list 25/-); British General Band Pass tuning units, 10-K.C. aerial or anode, 5/- each (list 14/6); H.M.V. volume controls, 1/6 each (list 12/6).
RECEIVERS.—Burgoyne 3-valve battery transportable sets, complete with valves, batteries, accumulator and speaker, £3/2/6 (list £7/19/6), new in cartons.
ALL Goods Guaranteed New and Perfect and Sent Carriage Paid.
PLEASE Note.—We have opened branches at 271-275, High Rd., Willesden Green, N.W.10, and at 46, Lisle St., W.C.2, where callers are cordially invited to inspect our large stocks of wireless bargains. Please send all post orders to 323, Euston Rd., N.W.1.
SOUTHERN RADIO, 323, Euston Rd., London, N.W.1 (near Warren St. Tube). Phone: Museum 6324. [3696
MR.D. Co. Offer the Following Unique Guaranteed Surplus; carriage paid or call. [3649
RECEIVER Chassis, complete with all components, ready for wiring; 2-valve, A.C., £2; 2-valve, D.C., £2; 3-valve, A.C., S.G., Det., Pen., 2-gang tuning, £3/5; 3-valve D.C. ditto, £3/5.
DUR-AMSCO 3-gang 0.0005 Condensers, trimmers, drum drive in wavelenghts, 7/9; Benjamin valveholders, 5-pin chassis or 4-pin sprung, 1/3 half dozen.—The Mains Radio Development Co., 4-6, Maxwell Hill Rd., London, N.6. [3700
NEW A.F.5c, 19/6; Colverdynes, 5/11, 3 for 17/-;—Gleed, Optician, Raynes Park. [3649
DON'T Buy Till You've Sent 1/6d. stamp for largest clearance list in the country.—Radio Mart.
FOUR Orders Only Returned in Years of Trading; no misrepresentation.—The Square Dealers, Radio Mart, 19, John Bright St., Birmingham. [3653

TURN YOUR D.C TO A.C THIS SIMPLE WAY...

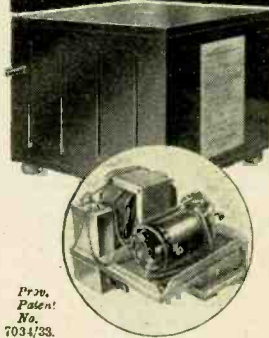

All the best Receivers are made for A.C. Power. The "NO-RO-CO" (non-rotary) Converter enables you to run A.C. sets from D.C. Power mains immediately. Works on voltages from 200-250. Operates sets from 2-valve to 9-valve. Fitted with specially made ball-bearing motor with automatic switch and cut-out. Noiseless and safe. Fully guaranteed. Can be installed by a novice in a few minutes. Revolutionary in practice and revolutionary in price. Send for fully descriptive leaflet.

THE "NO-RO-CO" CONVERTER

THE WILROSE CO(BHAM) LTD. £5.19.6
47, CORNWALL ST. BIRMINGHAM
Cash with order. Money refunded if not satisfactory. Trade enquiries invited, invaluable to dealers on D.C. mains.

GOOD RECEPTION MEANS RECEPTION

INSULATED AERIAL CABLE in the ORANGE & BLUE CARTON
"Reception" can be used either as an indoor or outdoor aerial or as an earth. It is a seven-strand insulated aerial cable drawn from pure electrolytic copper and protected with a weatherproof covering, and is definitely non-corrosive. The conductivity of the aerial is, of course, extremely high, so that when "Reception" is fitted perfect satisfaction is assured. Obtainable from all Wireless dealers, or if in difficulty apply direct to the manufacturers.
THE CONCORDIA ELECTRIC WIRE CO. LTD. New Sawley Nr. Nottingham

Mr. EXPERIMENTER—

Follow the lead of the manufacturers and make your connections and nuts positively secure with—

"SHAKEPROOF" LOCK WASHERS



AND LOCKING TERMINALS.
British Patent 194987.
The twisted teeth bite into the metal and prevent "slacking off." The more the vibration, the tighter they grip.
ASK YOUR DEALER FOR "SHAKEPROOF."
Manufactured by BARBER & COLMAN Ltd., Brooklands, Manchester
Dealers and factors' enquiries to:— WM. CLARK (Spare Parts) Ltd., 5, Marshalsea Rd., London, S.E.1.

OPENINGS for ENGINEERS!

Never before has engineering offered such magnificent chances. With the rise of the depression, the industry is literally teeming with first-class opportunities. Our 250-page Hand-book "ENGINEERING OPPORTUNITIES," shows where the opportunities lie, and the easiest way prepare for them. The Hand-book gives details of A.M.I.Mech.E., A.M.I.E.E., A.M.I.C.E., G.P.O., etc., Exams., outlines Home-Study Courses in all branches of Civil Mech., Elec., Motor, Radio & "Talkie," Engineering, Building, etc., and explains our unique Employment Dept. Send for this valuable Hand-book to-day—FREE! BRITISH INSTITUTE OF ENGINEERING TECHNOLOGY, 337, BAKER'S SHED HOUSE, 29, OXFORD STREET, LONDON W.1.

ELECTRADIX BARGAINS

Write for latest Sale List "W"
ELECTRADIX RADIOS, 218, Upper Thames Street, E.C.4.

Components, etc., for Sale.—Contd.

CHAL-ELECTRIC Offers New Set Manufacturers' Surplus all carriage paid; cash with order, or c.o.d.

VARIABLE Condensers—J.B. Nu Gang (3-gang), complete with disc drive, covers, trimmers, escutcheon, light knob, etc., 17/6; 2-gang, fitted as above, 9/6; Polar Star (3-gang 1933), complete, fitted as above, list 30/6, at 18/-; Uniknob 2-gang, fitted as above, complete, 10/-; Utility 2-gang, fitted as above, 8/6.

COILS (6 sets each only).—Colvern Ferrocart, F1, F2, F3 ganged, 32/-; Varley Ni-core (1), B.P.30 and 2B.P.31, 28/-; Varley sets, B.P., 19 ganged, 25/6. (3 only) British Radiophone R.F. superhet Radiopak, list 75/-, at £3. (2 only) Colvern Colpak, type H, list 57/6, at £2/8.

SMOOTHING Condensers—C.E.C. Murphy, etc., 800 test 250 A.C. working, 1 mid. 1/1, 2 mid. 1/9, 4 mid. 2/6; all the following 1,500 D.C. test 500 A.C., working 800 peak, 1 mid. 1/9, 2 mid. 2/4, 4 mid. 4/-; Multiple Banksall, separate tapings, 20 mid., 4+4+2+2+2+2+2+1+1 at 11/-, 11 mid., 4+2+2+2+1, at 6/9.

GRAMOPHONE Motors, B.T.H., Trusped (2 each only), A.C., list 49/6, at 43/-; D.C., list 67/6 at 55/-; Universal, A.C./D.C., list 110/-, at 90/-.

ASK for Special Quotation for Anything You May Need.—Chal-Electric, No. 6, Conduit St. London, W.1.

METERS Moving Coil, Weston 301, 1 m.a., 27/6; 5 m.a., 25/-; 10 m.a. and upwards, 22/6; Galvos 30-0-30, 27/6.

NEW British Made, 1 m.a., 27/6; 250 volts (1,000 w. per volt), 32/6; Turners 20 m.a. upwards, 17/6; thermo ammeters, 1.5a. 22/6; French 3-range, 3 m.a., 6v., 240v., 22/6. 2-range, 2 m.a., 240v., 20/-; German 2 m.a., 25/-; 2,000 volts, 32/6; assorted makers, 25 m.a. and upwards, 10/6; laboratory apparatus in stock; meter repairs a speciality.—The Victa Electrical Co., 47, High St., Battersea, S.W.11. 'Phone: Batt. 0780.

EBURY BRIDGE RADIO Offer the Following Stupendous Bankrupt and Set Manufacturers' Surplus Bargains.

A.C. High Tension Eliminators, input 200/50 volts, output 150v. 30 m.a., 3 pos. tapings, one fixed, one continuously variable, one 8.G., finest components, guaranteed, Westinghouse rectified, 28/6; 2 pos. tapings, one con. variable, 25/-; post 1/3; also in 100/110v. D.C. outputs as above, 3 pos. taps, 12/6; 2 pos. taps, 10/-; post 9d.

GENUINE Reisz P.A. Microphones, for all speech amplifying, 55/-; nickel plated stand, with oxy base and rubber suspension, 15/-; special matched transformer, 5/-; all post free.

BARGAIN Offer—Rola F6 moving coil speakers, 6,500 ohms, 14/-; for A.C. mains, Westinghouse rectified, 24/-; post 1/3.

EX Ekco Mains Transformers, suitable Ferrocart III, tapped 200/50v. input, outputs, 350-0-350v. 70 m.a., 4v. 2a., 4v. 3-4a., C.T.; 9/6; post 9d.; real snip.

EX Ekco Heavy Duty Smoothing Chokes, 50H. at 50 m.a., C.I., 5/6; post 6d.

UTILITY 0.0005 Condensers, with S.M. drum dial and escutcheon plate, new, boxed, 5/6; post 6d.; dial alone listed 10/-.

PYE Mains Transformers, 200/50v. input, outputs 135v. 60-100 m.a., 4v. 2a., C.T., 6/6; post 9d.; smoothing chokes, 30H., at 30 m.a., C.I., 600 ohms, 3/9, post 9d.

SPECIAL Offer of Ebury Electric Clock Movements, robust, reliable, 200-50v. 50c., 16/6, post 6d.; write full details.

CONDENSER Bargains—All working voltages, T.C.C. 3 mf., 800v., 5/-, post 6d.; 9 mf. (4+4+1), 250v., 3/6, post 6d.; 15 mf. dry electrolytic 100v. for auto C.B., 1/3, post 2/6d.; Siemens 4 mf. 250v., 2/-; Hydra 2 mf., 250v., 1/6; Wego 500v. 2 mf., 1/9; Wego 2 mf., tapped for decoupling, 1/3, all post 6d.

CHASSIS Mounting Valve Holders, 4-5-pin, 3d. each, post 1/4d., 2/6 doz., post 3d.; Leowe 4-Watt vacuum resistances, 50,000 and 100,000 ohm, 9d. each, post 1/4d.; manufacturers parallel intervalve transformers, 2/6, post 3d.; Toggle switches, 6d. post 1/4d.

ALL Goods 3 Days' Approval Against Cash or c.o.d.

EBURY BRIDGE RADIO Co., 33, Ebury Bridge Rd., B.W.1, near Victoria Station (No. 11 bus to Ebury Bridge). Sloane 8407. [3703]

ONE Varley B.P.19, 20/-; 2 Colvern I.F.T., type 110, 1 Varley I.F.T. B.P.21, 5/- each.—Box 8331, c/o The Wireless World. [3679]

WEST END RADIO STORES for Bankrupt Stock Bargains.—"Fay" home recorders, complete with diamond stylus, needles, etc.; 5/6, list price 51s. 6d.

"FAY" Microphone, complete with transformer, stand, battery, new and guaranteed, 25/-, usual price £3/3; blank records for Fay sets, 6in. 2/9 doz., 8in. 5/6 doz., 10in. 8/6 doz., all double sided.

MAINS Transformers—British H.T.B. 200v. 180 m.a., 4v. 4a., 4v. 1a., 4/9; Heyberd, 350-0-350v., 60 m.a., 4v. 4a., 4v. 2a., 6/6; Edison Bell, 400-0-400v. 120 m.a., 4v. 5a., 6v. 3a., 7.5v. 3a., 12/6.

H.T.7 Trans. for 100-110v., 135v. 90 m.a. 4v. 3a., 4/6; T.C.C. 3.25 mid. condensers, 500v. test, 2/6.

HARLIE Pick-up, with volume control, 10/6, 27/6 model; genuine N.K. Farrand inductor speakers, 22/6, list price 70/-.

COLLARO Electric Induction Gramophone Motors; 35/-, £3 model.

POSTAGE Extra On All Orders.—West End Radio Stores, 14, Lisle St., Leicester Sq., W.C.2; and at 382, Coldharbour Lane, Brixton, S.W. [3659]

AMERICAN Valves, receiver spares, components, speakers; speedy repair service to the trade.—Henry Ford Radio, 56, Howland St., W.1. Museum 5675. [3662]

MIRRORS, glass, plano, 2/-; lenses, bullseye, 8d., 1/-; 2/6; large heavy solenoids, 110v., 220v., 20 lb., 20/-; packing carriage above extra.—Beaton, Chalk Farm Rd., N.W. [3671]

ONE Watt Carbon Type Resistances, all values from 500 ohms to 1 megohm, 1/4d. each, or 1/- per dozen, plus postage, special prices for large quantities.—Box 8305, c/o The Wireless World. [3643]

RADIOPHONE Radiopaks, superhet type, 50/-; Band-pass type, 37/6, both guaranteed perfect; B.T.H. P.M. speaker, with Ferranti O.P.M.4, 28/-; high class new and second-hand components obtained to order.—Aldridge, 29, Chatterton Rd., London, N.4. [3685]

FERRANTI A.F.5, 16/-; Multitone, Class B, 7/6; Varley Niclet, 3/6; R.I. Parafed, 4/- (second-hand); Telsen 10-1, 6/-; Pico meter, 7/6; Wates 3-in-1, 4/6; 0-10 m.a., flush, 7/6; Ormond £3/5 P.M. speaker, 50/-; all perfect.—Hulbert, 24, Pargeter Rd., Warley, Birmingham. [3694]

SET Colvern Ferrocart Coils, 24/-; set Colverdynes, 23/-; T.C.C. 8 mid. Electrolytics, 2/6; Radiophone horizontal dial drives, 5/6; Varley Nicore coils, 7/-; Garrard automatic record changer, £6/16; Westinghouse rectifiers, 320-volt 60 mills., 6/6; 350-volt 120 m.a., 7/10; 300 volts 50 mills., 5/6.—Williams, 233B, All Souls Av., Willesden, N.W.10. [3665]

THEY ALL USE T.C.C. ALL-BRITISH CONDENSERS

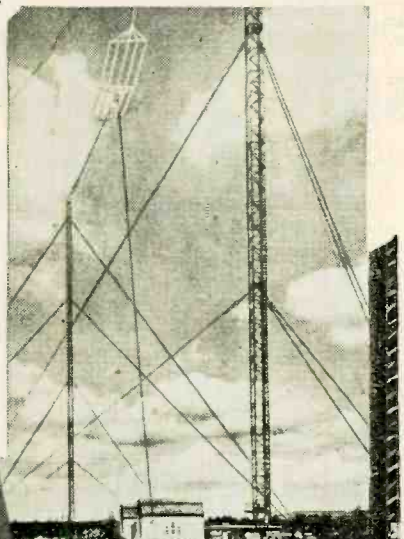

BUDAPEST

SOTTENS

WEST REGIONAL

KALUNDBORG

MORE STATIONS USING T.C.C. CONDENSERS

- MIDLAND REGIONAL
- NORTH REGIONAL
- SCOTTISH REGIONAL
- PRAGUE
- BUENOS AIRES
- MOTALA
- GOTHENBURG



LONDON REGIONAL



EMPIRE BROADCASTER



BUCHAREST

THEY ALL MAKE SURE — SO CAN YOU — USE ONLY T.C.C.

THE TELEGRAPH CONDENSER CO. LTD., WALES FARM RD., N. ACTON, W.3.

Photos: B.B.C., Topical Press, Photopress, Rachmann, Gerber.

3649

BULGIN
In a Class alone **H.F. CHOKES**

Registered Design No. 773899.

THIS season's outstanding range, all conforming fully with modern screened practice. Designed for base-board or chassis mounting. Note particularly the high inductance values and competitive prices.

- List No. **MIDGET SCREENED H.F. CHOKE** Price **H.F.8** Small and neat, can be incorporated in the smallest receivers and will give excellent results. Tested inductance 198,000 mH. Self capacity 3.5 mmF. **2/3**
- STANDARD SCREENED H.F. CHOKE** **H.P.9** A splendid general-purpose component for use with modern high-efficiency valves. Tested inductance 250,000 mH. Self capacity 2.5 mmF. **3/6**
- SUPER EFFICIENT H.F. CHOKE** **H.F.10** An unparalleled performance. Straight line from 100 to 2,500 metres. Tested inductance 500,000 mH. Self capacity 1.5 mmF. **5/6**

Send for 80-Page Catalogue No. 153 W. Enclose 2d. postage



Telephone: GRANGEWOOD 3266

Telephone: GRANGEWOOD 3267

A. F. BULGIN & CO., LTD., ABBEY ROAD, BARKING, ESSEX
London Showrooms: 9, 10, 11, Cursitor Street, Chancery Lane, E.C.4

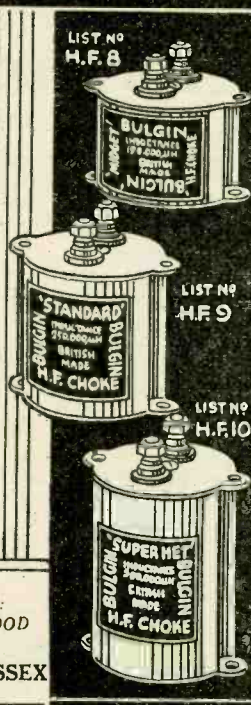

CLASS "B" COMPONENTS.
SOUND SALES, Ltd., for Class "B" Components. List "B.B." on request.—Tremlett Grove, Highbury, N.19. (0401)

MISCELLANEOUS.

EASY Payments.—We supply, by easy payments, components, accessories, and sets, any make; 10% down, balance spread over 11 months.—Send list of requirements to London Radio Supply Co., 11, Oat Lane, London, E.C.2. [0337]

AMBITIOUS Men.—Quality for a well-paid post by studying at home with the T.I.G.B. Write to-day for "The Engineer's Guide to Success," 144 pages, free, which contains the widest selection of engineering and wireless courses in the world, and shows you how to become A.M.I.E.E., A.M.I.Mech.E., A.Rad.A., etc. State branch, post, or qualification that interests you.—The Technological Institute of Great Britain, 82, Temple Bar House, London, E.C.4. (Founded 1917. 19,000 successes.) [3585]

ENGINEERS and Technical Workers of All Kinds.—A proper training by post in your spare time will take you through your right examination, the employment is waiting. Our advice on all careers free.—Dept. 92, The Bennett College, Ltd., Sheffield. [0395]

PATENT AGENTS.

A. MATHISEN, B.Sc., Patent Agent and Consulting Electrical Engineer, First Avenue House, High Holborn, London, W.C.1. Holborn 8950. [3496]

PATENTS and Trade Marks, British and Foreign.—Gee and Co. (H. T. P. Gee, Member R.S.G.B. and A.M.I.R.E.). 51-52, Chancery Lane, London, W.C.2. Phone: Holborn 1525. [0001]

PATENTS.

THE Proprietor of British Patent No. 230642, relating to "Improvements in radio telephone signalling," is desirous of entering into negotiations with one or more firms in Great Britain for the purpose of exploiting the invention either by sale of the patent rights or by the grant of licences on reasonable terms; interested parties who desire further particulars should apply to Dr. Albert L. Mond, 19, Southampton Buildings, Chancery Lane, London, W.C.2. [3648]

REPAIRS.

MAJNS Transformers Rewound; prompt service, satisfaction guaranteed; prices on request.—The Sturdy Electric Co., Wesley Terrace, Dipton, Newcastle-on-Tyne. [3522]

HENRY FORD RADIO, leading service specialists for American sets, also British, trade work particularly.—56, Howland St., Tottenham Court Rd., W.1. Museum 5675. [3661]

REPAIRS.—Rebuilding to any set; highest quality work only; lowest charges; estimates given free; distance no object.—L. Eastwood, Radio Manufacturers' Consultant, late of His Master's Voice and Marconi Wireless Telegraph Co., Telephone: Clerkenwell 4520. Address: 70, Pitfield St., Hoxton, N.1. [3544]

GUARANTEED Repairs by Experts; specialists for repairs to S. G. Brown and Ampion radio apparatus, also loud-speakers, headphones, pick-ups, Blue Spots, any type rewound, reimagined and adjusted; 4/-; post free; mains transforme, repairs; terms to trade.—Howell, 91, Morley Hill Enfield Middlesex. [9716]

REPAIRS to Loud-speakers, transformers and headphones, 4/-; Blue Spots or Wufas, 5/-, post free; moving coils a speciality, new cones fitted; eliminators and mains transformers quoted for; prompt service; satisfaction guaranteed; discount to trade.—Loud Speaker Repair Works, 5, Balham Grove, London. Battersea 1321. [0394]

TUITION.

RECOGNISED Qualifications Assure Success in Radio.—Send P.C. for particulars and free specimen lesson of home study courses; private evening classes arranged.—Radio Training Institute, 85, New Oxford St., London. [3584]

QUALIFIED Radio Engineers are Always in Demand, and our Home Study Course will enable you to qualify for a good post; many students already placed this season; prospectus free.—Northern Counties Wireless School, Preston. [0399]

EXCHANGE.

EXCHANGE Your Set or Components for New; best allowance.—Radio Exchanges, 114, Ramuz Drive, Westcliff-on-Sea. [3556]

BIRMINGHAM RADIO MART'S Clearance List, saves 60%; 1/6d. stamp brings it; most varied stock in country.—19, John Bright St., Birmingham. [3651]

DEAL With the Firm that Gives You the Highest Possible Allowance in Exchange; sets or components; prompt attention and deliveries.—Mildmay Radio Exchange, Phone: Clissold 5001. 24, Mildmay Grove, London, N.1. [3658]

HIGH Allowances made on Second-hand Goods in Part Payment for New Sets or Components; easy payments available; we have tremendous stocks tested second-hand goods; send list of your requirements for quotation.—Bostock and Stonnill, 1, Westbourne Terrace, S.E.23. [3663]

WANTED.

WANTED.—Burndept needle armature pick-up, in sound condition.—90, Sevington Rd., Hendon. [3691]

WANTED.—"W.W." all-wave battery monodial super-het; cheap; or Diode Quality Four.—BM/B88N, London. [3666]

WANTED. Ferranti 0.1 milliammeter, also old and curious valves, single specimens welcome.—Box 8337, c/o The Wireless World. [3695]

SPOT Cash for Modern Components, etc.—Economic Radio Co., 96-98, South Lambeth Rd., S.W.8. [3291]

SURPLUS and Second-hand Goods, any quantity; for cash.—Woburn Radio Co., 7, Woburn Buildings, W.C.1. Euston 1571. [3569]

HIGH-Class Radio Parts and Sets Wanted for cash, new or second-hand, any quantity; send yours stating reasonable price cash by return; retailers' stocks purchased.—Mildmay Radio Exchange, 24, Mildmay Grove, London, N.1. Phone: Clissold 5001. [3453]

BUSINESSES AND PROPERTY FOR SALE, TO BE LET, OR WANTED.

SURREY Suburbs.—Established wireless and electrical business for disposal; d.f. shop premises in new shopping parade near station; rapidly growing district; good stock; valuable equipment; taking about £2,500 p.a.; every investigation; price £750, including stock.—Godard and Smith, Specialist Radio Auctioneers, 70, Seymour Place, W.1. Paddn. 0277-8. [3684]

SITUATIONS VACANT.

REQUIRED for Radio Factory, S.E. London, youths for wiring and assembling.—Write Box 8310, c/o The Wireless World. [3644]

RADIO Testers Required; applicants must have held similar appointment; write fully to Chief of Test. Reo Wks., Southend-on-Sea. [3676]



WIREWOUND

WATMEL KNEW WHAT YOU WANTED

SO HERE IS THE HYWATT

A resistance that will not break down, one that will stand high overloading, is moisture-proof and noiseless.

The Hywatt is a definite advance in Resistance manufacture.

Due to its wire element it is unchangeable in operation, has a much closer tolerance than the carbon type and a fixed resistance value.

This is why so many set manufacturers have chosen the Hywatt for their 1934 sets.

Made in all values from 1-50,000 ohms.

For full details please write to:

WATMEL WIRELESS CO. LTD., Imperial Works, High Street, Edgware, London. Telephone: Edgware 0323.



Specified again! Turn to the A.V.C. Three report and see the Watmel Specifications. (95)

EVERY TEST WITH ONE INSTRUMENT ONLY

The Avometer is indispensable to the Service men of leading radio manufacturers as the only instrument which adequately meets their needs. It is the only complete testing instrument giving direct readings in amps, volts and ohms without the necessity for mathematical calculations.

Two models: One for D.C. only 8 Gns., and the Universal Avometer, giving both D.C. and A.C. readings (50 cycles*) 12 Gns. *Referred Terms if desired

Fully descriptive pamphlets free on application.

D.C. AND A.C.

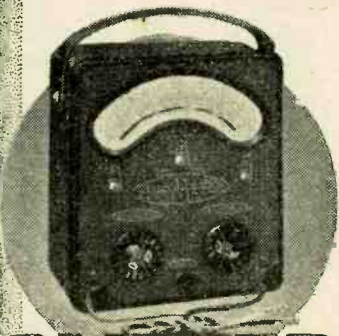

The AVOMETER

REGD. TRADE MARK

THE AUTOMATIC COIL WINDER AND ELECTRICAL EQUIPMENT CO., LTD., Winder House, Douglas Street, London, S.W.1.

Phone: Victoria 3405-7.

BRITISH MADE

Situations Vacant.—Contd.

RADIO Testers Wanted Urgently, for details of inexpensive postal training by foreman test engineer, write Box 8335, c/o *The Wireless World*. [3692]
OPPORTUNITY for Smart Youth in Radio and Electrical shop, W. London; state age, experience and salary required.—Box 8324, c/o *The Wireless World*. [3656]
OPPORTUNITY for Keen Youth (16-18) to Gain Factory Experience in Radio Receiver Manufacture.—Write particulars of education and experience, Box 8333, c/o *The Wireless World*. [3681]
If You Wish to Enter the Wireless Profession with a Thorough Training, or if you wish to improve your present position, you will need the certificate issued by Britain's leading wireless college. This is not a correspondence college. Apparatus of all leading makes installed for instructional purposes. Boarders accepted. Training fees can be paid after appointment. Prospectus free.—Wireless College, Colwyn Bay. [0388]

SITUATIONS WANTED.

ENGINEER (20), P.M.G., 5 years' experience sales, service, desires progressive situation, any capacity.—Box 8329, c/o *The Wireless World*. [3677]
YOUNG Man Requires Position with Radio Firm, sales or service, good practical and technical knowledge, experienced mains sets, M.C. speakers.—Box 8330, c/o *The Wireless World*. [3678]
B.H.C. Engineer, A.M.I.R.E., etc., ex marine operator, seeks change; experience includes 5 years' commercial radio as correspondent, designer, service manager, with large London manufacturers.—Box 8325, c/o *The Wireless World*. [3655]
POSITION Wanted by Young Man, P.M.G., City and Guilds Radio, A.M.I.R.E., 3 years on radio station abroad, previous experience factory test dept., sound technical knowledge all branches, keen, used to typing and Spanish.—Box 8243, c/o *The Wireless World*. [3592]
 Owing to pressure on our space several advertisements are held over till next week.

Wireless World TEST REPORT

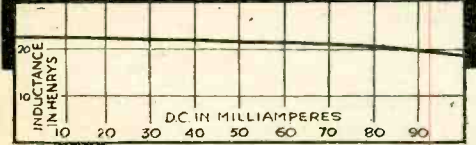

The above chart reproduced from "The Wireless World" Test Report, emphasises the remarkably **Constant Inductance** of Sound Sales' Chokes.

14' Specified for the **A.V.C. THREE SOUND SALES 30hy CHOKE, 14'**

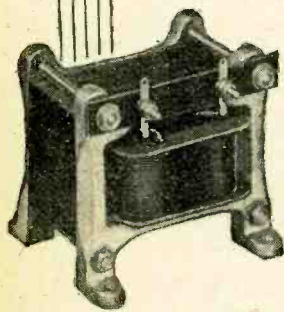

A replica in design of the famous 10hy Choke, used in all models of the **MONODIAL**

Illustrated catalogue "W" of all Sound Sales' products on request

Specified by **SOUND SALES** the Experts

SOUND SALES LTD. Tremlett Grove, Highgate, London, N.19
 Phone: Archway 1661-2

TRIX AMPLIFIERS

Model T.110A, 3½ watts speech output £10-10-0 including speaker. Send for illustrated lists and free estimate for any P.A. installation, small or large, permanent or for hire.
 E. J. Lever (TRIX) Ltd., 8/9, Clerkenwell Green, London, E.C.1

CATALOGUE 1933-34 NOW READY FOR THE TRADER.

Perseus supplies all makes **KITS OR PART KITS,**

or any components, valves or Speakers, at best discount. **LATEST WIRELESS WORLD & OTHER JOURNAL KITS.** First in delivery. Latest information: 120 pp. illustrated catalogue 6d. stamps. Personal attention of the proprietor.
PERSEUS RADIO, W.W. Burton - on - Trent.

SUPERIAL is too costly to IMITATE

In every way Superial is superior to all other Aerials. It has longer range super selectivity and crystal clear reception. It is simple to fix—no insulators are necessary and no separate lead-in is required.

Compare any other Aerial with Superial and you will realise the poor quality of the ordinary outer covering—examine more closely and you will discover that the imitation is made up entirely without the essential rubber vulcanization—therefore without protection. Get Superial and be safe—it costs only a little more, but is worth more than double. Then, of course, there is the extraordinary efficiency of the scientific combination of ferrous and non-ferrous metals (including copper) far superior to the copper only Aerial. Look at the illustrations below. The greatly enlarged photograph shows Superial with its seven strands completely encased from end to end with extra heavy vulcanized rubber insulation, so thick, it is actually like a rubber tubing. This insulation is then protected with heavy braiding and finally compounded and waxed to resist every condition of weather—hot or cold, all the year round for many years to come.

THE AERIAL WHICH MADE BROADCASTING POPULAR
SUPERIAL
 ELECTRON'S SUPER-AERIAL

100 ft. 3/6 : 75 ft. 2/6 : 50 ft. 1/9 : 25 ft. 1/-

From dealers everywhere

BEWARE OF IMITATIONS

LOOK AT THE NAME AND THE BOX

Scientific combination of highly conductive ferrous and non-ferrous soft metals.

Thick vulcanized rubber insulation, a real protection against corrosion.

Complete protection is ensured with Flax braiding, heavily waxed and compounded.



£500

FREE LIGHTNING INSURANCE FOR 2 YEARS

LOOK AT THIS POOR IMITATION. A piece of ordinary covered Aerial. The cheap cotton "covering" is not true insulation, neither is it a protection against corrosion or lightning. It quickly perishes on exposure, becomes unravelled and serves no useful purpose. Do not confuse it with vulcanized rubber insulation which is a perfect protection.

Telegrams:—
 "Stannum, London."
 Telephones:—
 Grange Wood 1408-9—1363

The NEW LONDON ELECTRON WORKS Ltd.
 92 EAST HAM LONDON.E.6

IMPROVE YOUR SHORT WAVE RESULTS

SHORT-WAVE ENTHUSIASTS will welcome this "EDDYSTONE" high efficiency lead-in device. It makes sure that weak short-wave signals from thousands of miles away are carried safely to the set without loss at the point of lead-in—usually the weakest link of any aerial system.

"EDDYSTONE" LOW LOSS LEAD IN
 CAT. No. 946,
 PRICE 2/6.

Latest list of "EDDYSTONE" short wave parts now ready, free on request.

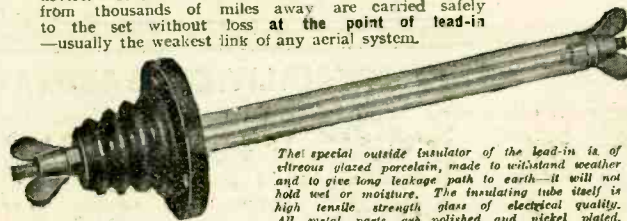

The special outside insulator of the lead-in is of vitreous glazed porcelain, made to withstand weather and to give long leakage path to earth—it will not hold wet or moisture. The insulating tube itself is high tensile strength glass of electrical quality. All metal parts are polished and nickel plated. Also suitable for use with transmitters.

STRATTON & CO., LTD., BROMSGROVE ST., BIRMINGHAM.
 LONDON SERVICE DEPOT—WEBB'S RADIO STORES, 164, Charing Cross Rd., W.C.2

EDDYSTONE
 LOW LOSS LEAD IN

INDEX TO ADVERTISEMENTS.

	PAGE
Automatic Coil Winder & Elec. Equipment Co. Ltd.	22
Baker's "Selhurst" Radio	20
Barber & Colman, Ltd.	20
Black, Alexander, Ltd.	24
Bon Marché, Ltd.	19
Bowyer-Lowe & A.E.O. Ltd.	8
Britannia Batteries, Ltd.	14
British Blue Spot Co., Ltd.	6
British General Manufacturing Co., Ltd.	6
British Inst. of Eng. Technology	18
British Pix Co., Ltd.	20
British Rola Co., Ltd.	17
Bulgin, A. F., & Co., Ltd.	22
Carrington Manf. Co., Ltd.	24
Celestion, Ltd.	19
City Accumulator Co., Ltd.	1
Cole, E. K., Ltd.	15
Concordia Electric Wire Co., Ltd.	20
Cossor, A. C., Ltd.	xxiv.
Dear, J. Tomalin & Co.	24
Direct Radio, Ltd.	17
Dubilier Condenser Co. (1925), Ltd.	Front Cover
Edison Swan Electric Co., Ltd.	7 and Inside Back Cover

	PAGE
Electradix Radios	20
Electrical Measuring Instruments Co., Ltd.	18
Epoch Radio Manf. Co., Ltd.	24
Ever Ready Co. (Great Britain), Ltd.	2
Faraday Allwave Wireless	10
General Electric Co., Ltd.	Inside Front Cover and 9
Graham Parish, Ltd.	3 and 5
Gramophone Co., Ltd.	12
Hartley-Turner Radio, Ltd.	18
Igranic Electric Co., Ltd.	10
Jackson Bros.	iv.
Lamplugh Radio, Ltd.	20
Lectro Linx, Ltd.	18
Lever, Eric J. (Trix), Ltd.	23
Lumen Electric Co.	24
New London Electron Works, Ltd.	23
Ormond Engineering Co., Ltd.	iii.
Partridge & Mee, Ltd.	Inside Back Cover
Perseus Radio	23
Peto-Scott Co., Ltd.	16
Pitco, Ltd.	8
Postlethwaite Bros.	24

	PAGE
Radiiformer, Ltd.	10
Radio-Gramophone Development Co.	Back Cover
Radio Instruments, Ltd.	8
Reproducers & Amplifiers, Ltd.	2
Riverside Manf. Co., Ltd.	24
Rotax, Ltd. (ML Equipment)	Front Cover
Savage, W. Bryan	24
Scott Sessions & Co.	20
Sonochorde Reproducers, Ltd.	Front Cover
Sound Sales, Ltd.	23
Stratton & Co., Ltd.	23
Tannoy Products	24
Telegraph Condenser Co., Ltd.	21
Telsen Electric Co., Ltd.	Front Cover and 13
Tungstram Electric Lamp Works (G.B.), Ltd.	4
Vortexion	6
Watmel Wireless Co., Ltd.	22
Westinghouse Brake & Saxby Signal Co., Ltd.	22
Wilrose Co. (Birmingham), Ltd.	Inside Back Cover
Wingrove & Rogers, Ltd. (Polar)	20
Wright & Weaire, Ltd.	4

House your moving-coil speaker in a "NUTONE"

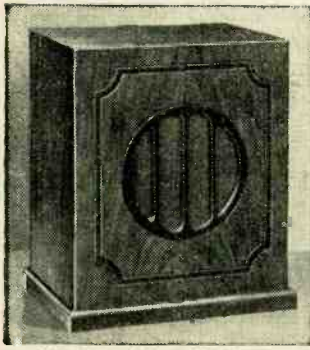

The "Nutone" Cabinet is specially designed for housing moving-coil speakers. Of simple, yet dignified design, it gives results equalling a large baffleboard in tone and quality. No trace of box resonance. Supplied in Oak, Mahogany, or Walnut finish, 32/6. See it at our Showrooms, or send for free Catalogue.

CARRINGTON Mfg. Co., Ltd.,
24, Hatton Garden, London, E.C.1.
Holborn 8202
Works: S. Croydon.



A.V.C. BATTERY
A.V.C. ANTI-FADING UNIT

ALL BATTERY SETS having one or more stages of H.F. or I.F. can now easily have A.V.C. fitted. (No special valve required.)
The WIRELESS WORLD says:

"The supreme merit of the system is its simplicity . . . usually means a very simple alteration . . . The unit can be confidently recommended as providing a simple means of reducing fading."

Entirely suitable for Ferrocart III., S.T. 300 and S.T. 400, Lissen "Skyscraper," Osram "Music Magnet," Cossor "Melody Maker," Telsen "Jupiter," Fury Four, Century Super, etc., and all Battery Superhets.

Dimensions of Unit: 2 x 2 1/2 x 1 3/8
Post Free U.K. and N.I. PRICE 10/-

Send for A.V.C. Unit together with full instructions for fitting.

J. TOMALIN DEAR & CO.,
22, GEORGE STREET, HANOVER SQUARE, W.1. Phone: *Maujfar* 5742.

TANNOY

- AMPLIFIERS
- SPEAKERS
- MICROPHONES
- RADIOGRAMS

'SOUND' EQUIPMENT FOR ALL PURPOSES. INDIVIDUALLY BUILT, NOT MASS PRODUCED

TANNOY PRODUCTS

GUY R. FOUNTAIN Ltd.,
CANTERBURY GROVE,
WEST NORWOOD,
LONDON, S.E. 27

MANCHESTER — BIRMINGHAM — SCOTLAND — IRELAND

EPOCH

MOVING COIL SPEAKERS

The Finest in The World in Each of Their Price-classes.

Ask your dealer or call for a demonstration at Exmouth House.

Send for New Booklet W.S.5a. It is free.

EPOCH RADIO MANUFACTURING Co. Ltd.
Exmouth House, Exmouth St., London E.C.1

At the Junction of Rosebery Avenue and Parrington Road,
*Phone: Clerkenwell 6596 (4 lines)

TRANSFORMER AND CHOKE STAMPINGS, INSTRUMENT AND RESISTANCE WIRES.

Lists Free

LUMEN ELECTRIC CO.
9, SCARISBRICK AVE., LITHERLAND, LIVERPOOL, 21

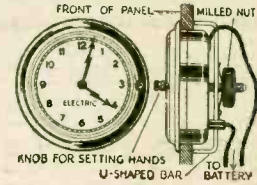

FIT THIS ELECTRIC CLOCK TO YOUR SET!
NO MAINS NEEDED!
KEEPS CORRECT TIME!
NO WINDING!

Works off small battery lasting 12 months, or can be plugged into G.B. Battery without affecting reception. Uses practically no current. Fits into hole 3 1/2" dia. in any panel up to 1 1/2" thick. Easy to fix—no screws required. Only 1/4" from front of panel to back of case. Swiss movement. Hands set from front. Nickel plated bezel. Useful addition to any set.

RIVERSIDE MFG. CO., LTD.,
Dept. 20, Crisp Rd., Hammersmith, W.6
Telephone: Riverside 6392.

12/6
COMPLETE WITH BATTERY
POSTAGE 6D

SAVAGE FOR MAINS TRANSFORMERS

56/58, CLERKENWELL ROAD, LONDON, E.C.1.

*Phone: Clerkenwell 3068/9.

FOR HIRE FULLY EQUIPPED PUBLIC ADDRESS VAN Sent anywhere in British Isles, also RADIO MICROPHONE, & GRAMOPHONE AMPLIFIERS giving exceptional quality and volume, suitable for Dances, Sports Meetings, Fetes, etc. from 15/- per day. McMichael Portable Sets 15/- a week: £2-12-6 a month.

ALEXANDER BLACK, LTD

WIRELESS CONSULTANTS

55, EBURY STREET, LONDON, S.W.1.

ESTABLISHED IN 1925.

SLOANE 1655.

Trade Inquiries Invited.

SERVICE

SETS OF ALL TYPES.

Supplied, Serviced and Visited in any district, or may be sent for Full Test and Report, at 2/- per valve-holder; portables 1/6 per valve-holder.



"KINVA" RADIO SPECIALITIES, LABORATORY DESIGNED AND TESTED.

Heterodyne-Whistle-Sideband Splash Filters, the New Ultra Efficient Type A3, Price 13/6; New Screened Type D, 7/6. Satisfaction guaranteed. New Iron-Dust Core Screened H.F. Choke, specially for H.F. Anodes, or for Diode Circuits, Price 4/6; Major Type, for Super-Hets., 5/6; Standard, 2/9. Tone Corrector Slab Chokes, from 0.1 H. to 2.0 H. Get list for details. Mains Transformers, the best possible only, 20 standard types from 21/-

Send for Descriptive Folder. POSTLETHWAITE BROS. (Dept. B), KINVER, STOURBRIDGE.

Printed for the Publishers, LIFFE & SONS LTD., Dorset House, Stamford Street, London, S.E.1, by The Cornwall Press Ltd., Paris Garden, Stamford Street, London, S.E.1.
Colonial and Foreign Agents:
UNITED STATES—The International News Co., 131, Varick Street, New York. FRANCE—W. H. Smith & Son, 248, Rue Rivoli, Paris; Hachette et Cie., Rue Réaumur, Paris.
BELGIUM—W. H. Smith and Son, 71-75, Boulevard Adolphe Max, Brussels. INDIA—A. H. Wheeler & Co., Bombay, Allahabad and Calcutta. SOUTH AFRICA—Central News Agency, Ltd.
AUSTRALIA—Gordon & Gotch, Ltd., Melbourne (Victoria), Sydney (N.S.W.), Brisbane (Queensland), Adelaide (S.A.), Perth (W.A.), and Launceston (Tasmania).
CANADA—The American News Co., Ltd., Toronto, Winnipeg, Vancouver, Montreal, Ottawa, St. John, Halifax, Hamilton; Gordon & Gotch, Ltd., Toronto; Imperial News Co., Toronto, Montreal, Winnipeg, Vancouver, Victoria. NEW ZEALAND—Gordon & Gotch, Ltd., Wellington, Auckland, Christchurch and Dunedin.

**study the modern method
of rectification . . .**



Get to know more about METAL rectification—the only method which has successfully withstood a test of 45,600 hours on full load. "The All-Metal Way 1934" contains full particulars and circuits—get a copy to-day by sending 3d. in stamps and the coupon below to:

THE WESTINGHOUSE BRAKE & SAXBY SIGNAL CO. LTD.,
82, York Road, King's Cross, London, N.1.

**Westinghouse
metal rectifiers**

Please send me a copy of "The All-Metal Way, 1934" for which I enclose 3d. in stamps.

Name
Address W.W.13.10.33.

**IF YOU CAN
AFFORD TO
BUY
PARMEKO**

**THE SATISFACTION
OBTAINED WILL
WELL REPAY YOU**

PARTRIDGE & MEE, LTD.
LEICESTER AND LONDON.

SPECIALISTS IN HIGH QUALITY
TRANSFORMERS, CHOKES,
SPEAKERS, AMPLIFIERS



Hear
**PAUL
ROBESON'S**
records as they
were meant
to be heard

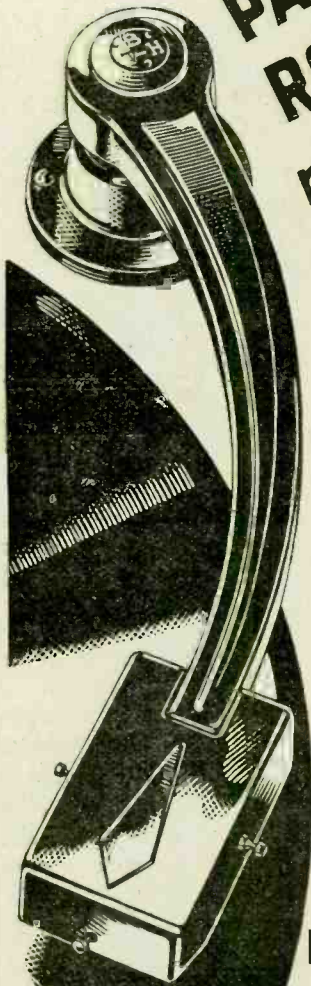

The greatest coloured singer the world has known, and artist to his finger-tips—Robeson has moved the hearts of millions. Hear the exquisitely unmistakable timbre of his voice when you play his records. Play them with a B.T.H. Pick-up. It's easy to fix in place of your old sound-box and tone arm. Then all you have to do is connect it to the "P.U." terminals on your set.

The "Senior" model for the connoisseur—the "Minor" model at 21/- for the man wanting good reproduction at a reasonable cost.

with a
SENIOR

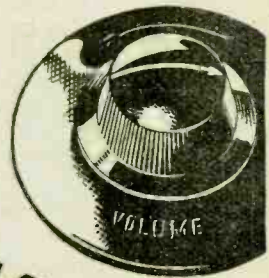

37/6
COMPLETE WITH
VOLUME CONTROL

PICK-UP

The Edison Swan Electric Co. Ltd.
155 Charing Cross Rd., London, W.C.2

GOOD RADIO DEALERS RECOMMEND EDISWAN

W.220

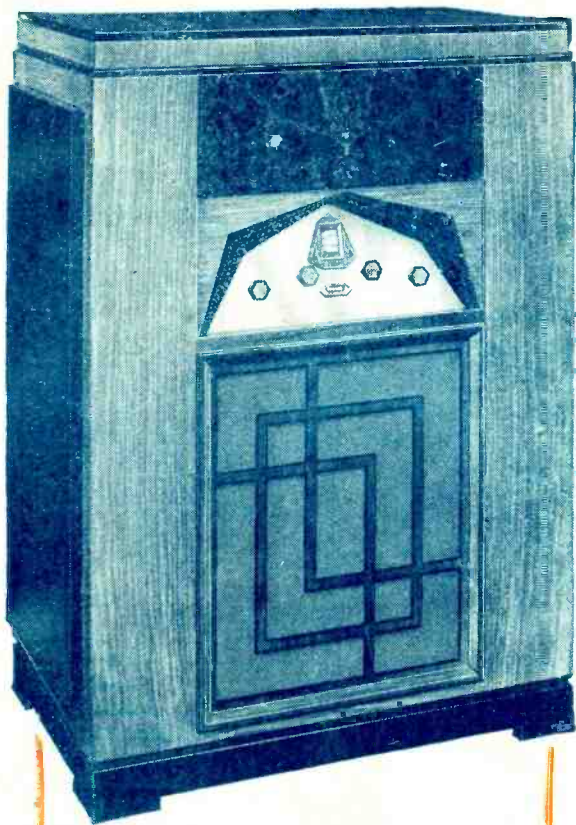

R.G.D. '1201' ULTRA MODERN RADIO GRAMOPHONE

This instrument contains the Model 1201 Auto. 12 Valve Chassis, Twin Speakers and Automatic Record Changer. The Cabinet is of light Ancona Walnut relieved with figured Macassar Ebony. Fittings are in harmony and comprise black hexagonal knobs and chromium plated panel. The automatic record changer is also in black with chromium fittings in harmony.

A magnificent instrument.

105 GUINEAS.
(A.C. only)

R G D
Radio Gramophones

RADIO GRAMOPHONE DEVELOPMENT CO., LTD., 17/20, Frederick St., Birmingham., MANCHESTER—17, Bridge Street. LONDON—40, Doughty Street, W.C.

WRITE FOR CATALOGUE

Some press opinions of the "Aristocrats of the Radio World"

VIDE "DAILY MAIL," 24th AUG.

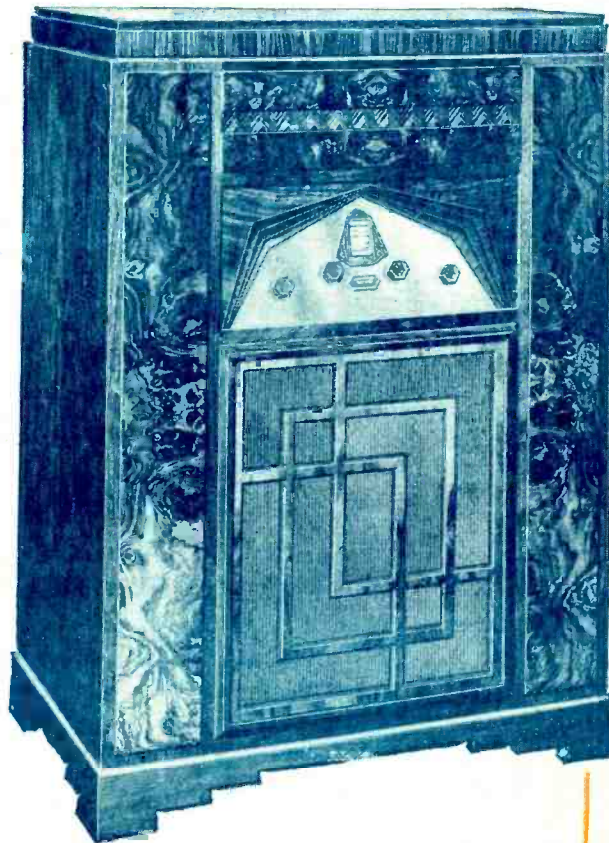

Model 1201 AUTO. 12 VALVE SUPERSONIC RADIO GRAMOPHONE

DELAYED ACTION AMPLIFIED AUTOMATIC VOLUME CONTROL

SILENT TUNING

VISUAL TUNING DEVICE WHICH SHOWS WHEN THE DESIRED STATION IS CRITICALLY TUNED

DUAL MATCHED LOUD SPEAKERS OUTPUT 6 WATTS

AUTO. RECORD CHANGER

CABINET IN FINELY GRAINED FIGURED WALNUT

1201 AUTO. 95 GNS. 1201 (without Auto. Record Changer) 86 GNS. (A.C. only)

Collie Knox, of the "DAILY MAIL," writing in the 24th Aug. issue—
"Yesterday I took another look round the show. I was particularly struck by the R.G.D. superhet radio gramophone at 105 guineas, which is, I must confess, the most superb instrument I have ever seen. The R.G.D. people have these machines all hand built. They are not built to any special price."

"DAILY MAIL," 24th Aug., also stated—

"Among the sets which have attracted the greatest interest, for design and engineering, particular credit goes to the R.G.D. Radio Gramophones. These can justly be termed the *aristocrats of the radio world*. From a general appearance point of view they rank as examples of craftsmanship of a high order. The exquisite cabinet work is of finely veneered figured walnut and the general appearance and proportions cannot fail to evoke the highest admiration. The outstanding achievement of R.G.D. Radio Gramophones is to be found in the chassis design and construction and its ability to receive practically every broadcasting station at home and abroad with ease, amazing clarity, and volume. Quality of reproduction is the *finest yet attained*, speech and music being rendered with a realism and tonal beauty that baffle description."

"DAILY EXPRESS," 13th Aug., stated—

"The de luxe designers such as R.G.D., of Birmingham, will *astonish* with their craftsmanship."

"BRISTOL EVENING WORLD," 21st Sept., stated—

"R.G.D. covers the initials of Radio Gramophone Development Co. Ltd., Birmingham, whose instruments are the *'Rolls-Royce' of Radio*. Expensive, you say! Well, they may appear so on the surface, but *the first cost is the last*. The reproduction is amazingly pure and faithful."

"The Rolls-Royce of Radio"